



TELEDYNE INSTRUMENTS
Advanced Pollution Instrumentation
A Teledyne Technologies Company

MODEL **701H**

High Performance Zero Air System



- ▶▶ **Standard two year warranty**
- ▶▶ **Regenerative, heatless dryer for maintenance-free water removal independent of inlet dewpoint**
- ▶▶ **Long life scrubbers for SO₂, NO, NO₂, O₃, H₂S, CO and Hydrocarbons**
- ▶▶ **Dewpoint sensor/alarm**
- ▶▶ **Automatic water drain**
- ▶▶ **Automatic pump control based on flow demand**
- ▶▶ **Ideal zero air for “trace level” or “ultra-sensitive” measurement applications**
- ▶▶ **May be used to provide combustion air for FID**
- ▶▶ **Source of purge air for permeation tube ovens**
- ▶▶ **Zero air for Ozone Generators**

The Model 701H is an excellent source of high purity zero air for all your process and analytical instrument needs. It is the ideal zero air source for ambient background monitoring applications using highly sensitive analyzers such as the model 100EU, 200EU and 300EU trace gas analyzers. It also may be used as a source of purge air for permeation tube ovens or burner air for FID analyzers. The regenerative, heatless dryer removes water and produces gas with a dewpoint of less than -25°C (dependant on flowrate), and assists in the removal of other gases, greatly increasing the life of the chemical scrubbers.

The Model 701H includes a high flow rate oil and diaphragm free pump, scrubbers to remove SO₂, NO, NO₂, O₃ and H₂S, and high performance scrubbers to remove CO and Hydrocarbons. The 701H also incorporates a dewpoint sensor that warns if the dewpoint exceeds -16°C.

Inlet air is pulled into the pump and routed through a pre-cooler and water trap to remove moisture. The air then passes through the regenerative scrubber for final drying and then to the storage tank.

Tank pressure is monitored and maintained at a preset level by cycling the pump automatically as needed, thereby extending both the pump and scrubber life. Outlet air then passes through a filter to assure a clean, dry, analytical zero air supply.

A microcontroller cycles the regenerative dryer and water trap valves preventing the pump from starting against full head pressure.

FREE Customer Support by telephone and email for the life of the instrument



MODEL 701H

High Performance Zero Air System

Specifications

Output: 20 SLPM @ 35 psig (at full performance specifications)

Dewpoint: -25°C ≤ 20 LPM
-30°C ≤ 5 LPM

Dryer: Regenerative heatless dryer with lifetime of greater than 5 years

Output concentrations (maximum):
SO₂ < 0.025 ppb
NO < 0.025 ppb
NO₂ < 0.025 ppb
O₃ < 0.3 ppb
CO < 10 ppb
Hydrocarbons < 0.25 ppb

Pump: Internal long-life, oil-less piston pump

Mounting: Bench type mounting, rack mount optional

Dimensions (HxWxD): 8.75" (22.2 cm) x 17" (43.2 cm) x 28" (71.12 cm)

Weight: 55 lbs (25 kg)

Power Requirements: 100V 50/60 Hz, 115V 60 Hz, 220V 50/60 Hz, 230V 50 Hz, 240V/50 Hz, 400 Watts

Approvals: CE

Schematic

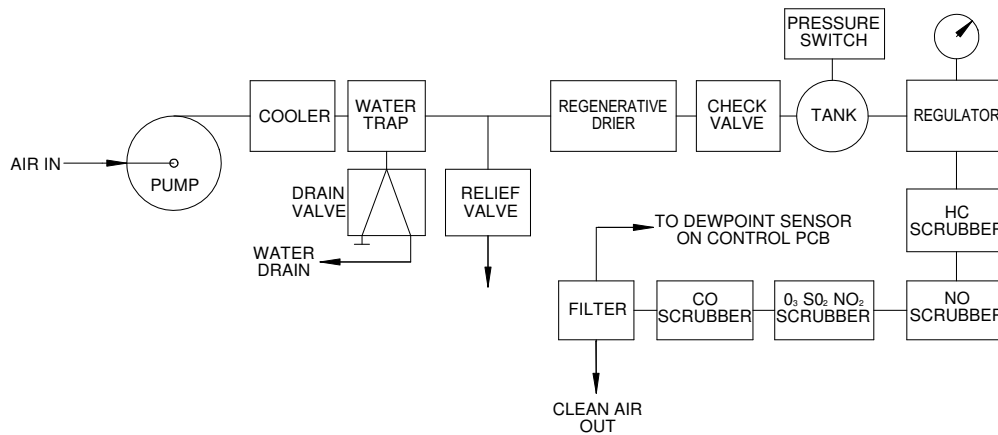

How to Order

Model 701H Zero Air System includes:

- Standard two year warranty
- Internal pump
- Regenerative dryer
- High performance scrubbers for SO₂, NO, NO₂, O₃, H₂S, CO & Hydrocarbons
- 30 SLPM pump
- Dewpoint sensor

Specify input AC voltage & frequency:

- 100V / 50 Hz
- 100V / 60Hz
- 220V / 50Hz
- 1150V / 60Hz
- 230V / 50Hz(CE)
- 220V / 60Hz
- 240V / 50Hz

Additional Options:

- Rack mount brackets (19") with chassis slides
- Rack mount brackets only
- 13 SLPM flow restriction

Specifications subject to change without notice. Printed documents are uncontrolled. SAL000031 A (DCN 5207) M701H 11/19/08



TELEDYNE INSTRUMENTS
Advanced Pollution Instrumentation

A Teledyne Technologies Company

9480 Carroll Park Drive ■ San Diego, CA 92121-5201

Ph. 858-657-9800 Fax 858-657-9816

Email api-sales@teledyne.com

For more information about the Teledyne API family of monitoring instrumentation products, call us or visit our website at

www.teledyne-api.com

