



TELEDYNE INSTRUMENTS
Advanced Pollution Instrumentation
A Teledyne Technologies Company

MODEL **360EM**

Gas Filter Correlation CO₂ Analyzer



- ▶▶ **Standard two year warranty**
- ▶▶ **Ranges, 0-4 ppm to 0-4000 ppm, user selectable**
- ▶▶ **Gas Filter Wheel for CO₂ specific measurement**
- ▶▶ **GFC wheel guaranteed for 5 years**
- ▶▶ **Multi-tasking software allows viewing of test variables during operation**
- ▶▶ **Continuous self checking with alarms**
- ▶▶ **Bi-directional RS-232 / RS-485 / Ethernet**
- ▶▶ **Digital status outputs indicate instrument operating condition**
- ▶▶ **Adaptive signal filtering optimizes response time**
- ▶▶ **Temperature & Pressure compensation**
- ▶▶ **Internal data logging with 1 min to 24 hour averages**
- ▶▶ **APIcom remote operation software**

The Model 360EM measures carbon dioxide CO₂ by comparing infrared energy absorbed by a sample to that absorbed by a reference according to the Beer-Lambert law. This is accomplished by using a Gas Filter Wheel which alternately allows a high energy infrared light source to pass through a CO₂ filled chamber and a chamber with no CO₂ present.

The light then travels through the sample cell, which has a folded path. The energy loss through the sample cell is compared with the zero reference signal provided by the gas filter to produce an output proportional to concentration, with little effect from interfering gases within the sample.

This design produces superior zero and span stability and a high signal-to-noise ratio, allowing excellent sensitivity. Multi-tasking software gives real time indication of numerous operating parameters and provides automatic alarms if diagnostic limits are exceeded. Built-in data acquisition and internal memory allows logging multiple parameters including average and instantaneous values, calibration data, and operating parameters. Stored data can be retrieved via the RS-232 port, ethernet, or from the front panel.

The Model 360EM features rugged construction and is designed to perform with a minimum of attention. Regular maintenance is greatly simplified through the use of modularization construction.

FREE Customer Support by telephone and email for the life of the instrument



MODEL 360EM Gas Filter Correlation CO₂ Analyzer

Specifications

Ranges:	0-4 ppm to 0-4000 ppm full scale, user selectable	Operating Temperature Range:	5 - 40°C
Units:	Dual, independent, and auto ranging supported ppb, ppm, µg/m ³ , mg/m ³	Dimensions (HxWxD):	7" (178 mm) x 17" (432 mm) x 23.5" (597 mm)
Zero Noise:	< 0.2 ppm	Weight:	40 lbs (24.0 kg)
Span Noise:	< 1.0% of reading above 20 ppm (RMS)	Power:	100V 50/60 Hz, 115V 60 Hz, 220V 50/60 Hz, 230V 50 Hz, 240V 50 Hz, 250W
Lower Detectable Limit (LDL):	0.4 ppm	Analog Outputs:	10V, 5V, 1V, 100mV, selectable
Zero Drift:	< 0.5 ppm/24 hours, < 1 ppm/7 days	Recorder Offset:	±10%
Span Drift:	< 0.5% of reading/24 hours, < 1% of reading/7 days	Serial Outputs:	Serial Port 1: RS-232, DB-9M Serial Port 2: standard RS-232 or optional RS-485, DB-9F, Ethernet
Lag Time:	10 seconds	Status (Digital):	8 outputs, 6 inputs (opto-isolated)
Rise and Fall Time:	< 60 seconds to 95%	Current Output:	Optional 4-20mA, select up to three channels
Linearity:	1% of full scale		
Precision:	0.5% of reading		
Sample Flow Rate:	800 cc/min ±10%		

NOTE: The values expressed above are in accordance with EPA definitions. All error specifications are based on constant conditions.

Schematic

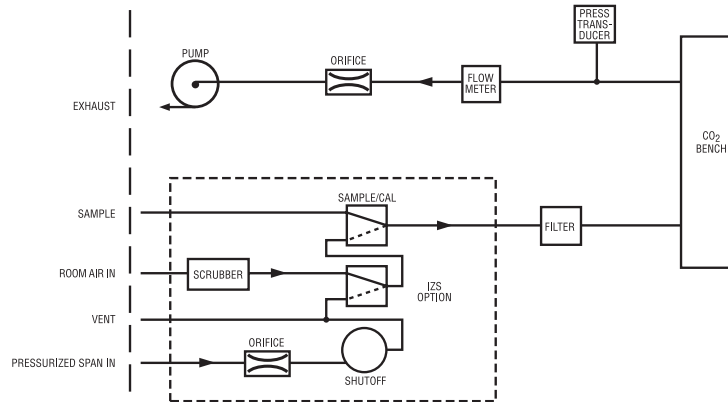

How to Order

Model 360EM Gas Filter Correlation CO₂ Analyzer includes:

- Standard two year warranty
- Internal pump
- Auto ranging and dual ranges
- 47mm diameter particulate filter
- 8 isolated digital status outputs
- 3 isolated digital inputs
- APIcom remote control software

Specify input AC voltage & frequency:

- | | |
|---|------------------------------------|
| <input type="checkbox"/> 100V - 115V | <input type="checkbox"/> 50Hz |
| <input type="checkbox"/> 220V - 240V | <input type="checkbox"/> 60Hz |
| <input type="checkbox"/> 230V/50Hz (CE) | <input type="checkbox"/> 220V/60Hz |
| <input type="checkbox"/> 240V/50Hz | |

Specify output DC voltage:

- 10V 5V 1V 100mV

Additional Options:

- Rack mount brackets (19") with chassis slides
- Rack mount brackets only
- 4-20mA outputs (specify up to three channels)
- Multi-drop RS-232 connection
- RS-485
- Ethernet

Calibration Valves:

- Stainless steel valves for selection of customer-supplied zero and span gas
- Shut-off valve and flow control for external span gas cylinder
- Internal zero air scrubber

Accessories:

- RS-232 Cable
- Expendables Kit
- Spare Parts Kit

Specifications subject to change without notice. Printed documents are uncontrolled. SAL000017 A (DCN 5058) M360EM/08/08/08.



TELEDYNE INSTRUMENTS
Advanced Pollution Instrumentation
A Teledyne Technologies Company

9480 Carroll Park Drive ■ San Diego, CA 92121-5201
Ph. 858-657-9800 Fax 858-657-9816
Email api-sales@teledyne.com

For more information about the Teledyne API family of monitoring instrumentation products, call us or visit our website at

www.teledyne-api.com

