



**TELEDYNE INSTRUMENTS**  
*Advanced Pollution Instrumentation*  
A Teledyne Technologies Company

MODEL **200E**

# Chemiluminescence NO/NO<sub>2</sub>/NO<sub>x</sub> Analyzer



- ▶▶ **Standard two year warranty**
- ▶▶ **Ranges, 0-50 ppb to 0-20 ppm, user selectable**
- ▶▶ **Independent ranges for NO, NO<sub>2</sub>, NO<sub>x</sub>**
- ▶▶ **Microprocessor controlled for versatility**
- ▶▶ **Multi-tasking software allows viewing test variables while operating**
- ▶▶ **Continuous self checking with alarms**
- ▶▶ **Permeation drier on ozone generator**
- ▶▶ **Dual bi-directional RS-232 ports for remote operation (optional RS-485 or Ethernet)**
- ▶▶ **Digital status outputs provide instrument operating condition**
- ▶▶ **Adaptive signal filtering optimizes response time**
- ▶▶ **Temperature & Pressure compensation**
- ▶▶ **Converter efficiency correction software**
- ▶▶ **Continuous automatic zero correction**
- ▶▶ **Catalytic ozone scrubber**
- ▶▶ **Internal Zero & Span check (optional)**
- ▶▶ **Internal data logging with 1 min to 365 day multiple averages**

EPA APPROVAL RFNA-1194-099  
MCERTS certified Sira MC050068/00  
EN Approval EN14211\*

The Model 200E uses the proven chemiluminescence detection principle, coupled with state-of-the-art microprocessor technology to provide the sensitivity, stability and ease of use needed for ambient or dilution CEM monitoring requirements.

The analyzer uses multi-tasking software which allows complete control of all functions while providing online indication of important operating parameters. Measurements are automatically compensated for temperature and pressure changes.

In addition, stability is enhanced by an Auto-Zero circuit that continuously provides a true zero reference. The result is sensitive, accurate, and dependable performance under the harshest operating conditions.

All instruments in the TAPI E Series include built-in data acquisition capability using the analyzer's internal memory. This allows the logging of multiple parameters including averaged or instantaneous concentration values, calibration data, and operating parameters such as pressures and temperatures.

Stored data are easily retrieved through the serial port or optional Ethernet port via APIcom or from the front panel, allowing the operator to perform predictive diagnostics and enhanced data analysis by tracking parameter trends.

The Model 200E combines lighter weight, rugged construction, ease of use, powerful diagnostics, modular design and outstanding performance to yield the ideal tool for today's air monitoring requirements.

***FREE Customer Support by telephone and email for the life of the instrument***



# MODEL 200E Chemiluminescence NO/NO<sub>2</sub>/NO<sub>x</sub> Analyzer

## Specifications

<b>Ranges:</b>	0-50 ppb to 0-20,000 ppb full scale, user selectable. Independent NO, NO <sub>2</sub> , NO <sub>x</sub> ranges and autorangeing supported	<b>Weight:</b>	Analyzer 40 lbs (18 kg) External Pump 15 lbs (7 kg)
<b>Units:</b>	ppb, ppm, µg/m <sup>3</sup> , mg/m <sup>3</sup>	<b>Power:</b>	100V - 120V, 220V - 240V, 50/60 Hz, 250W
<b>Zero Noise:</b>	<0.2 ppb (RMS)	<b>Analog Outputs:</b>	10V, 5V, 1V, 0.1V, selectable
<b>Span Noise:</b>	<0.5% of reading (RMS) above 50 ppb	<b>Recorder Offset:</b>	±10%
<b>Lower Detectable Limit (LDL):</b>	0.4 ppb	<b>Serial Outputs:</b>	Serial Port 1: RS-232 (DB-9M) Serial Port 2: standard RS-232 or optional RS-485 (DB-9F), Ethernet
<b>Zero Drift:</b>	<0.5 ppb/24 hours, <1 ppb/7 days	<b>Status (Digital):</b>	8 outputs, 6 inputs (opto-isolated), 4 alarm outputs (optional)
<b>Span Drift:</b>	<0.5% of reading/24 hours, <1% of reading/ 7 days	<b>Current Output:</b>	Optional 4-20mA, select up to three channels
<b>Lag Time:</b>	20 seconds	<b>Approvals:</b>	USEPA RFNA-1194-099, MCERTS certified Sira MC050068/00 EN14211* Approved, CE and others
<b>Rise and Fall Time:</b>	<60 seconds to 95%	<b>NOTE:</b> The values expressed above are in accordance with EPA definitions. All error specifications are based on constant conditions. Specifications exceed US EPA and Eignungsgeprüft requirements.	
<b>Linearity:</b>	1% of full scale		
<b>Precision:</b>	0.5% of reading		
<b>Sample Flow Rate:</b>	500 cm <sup>3</sup> /min ±10%		
<b>Operating Temperature Range:</b>	5 - 40°C (with EPA Equivalency)		
<b>Dimensions (HxWxD):</b>	7" (178 mm) x 17" (432 mm) x 23.5" (597 mm)		

## Schematic

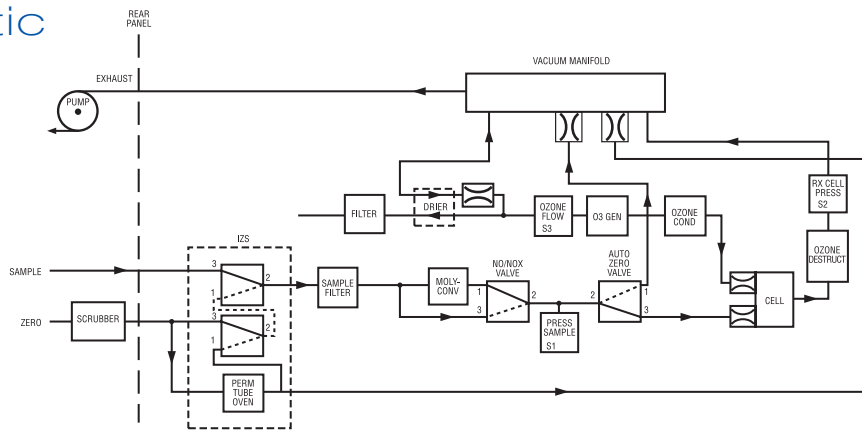

## How to Order

### Model 200E Chemiluminescence NO, NO<sub>2</sub>, NO<sub>x</sub> Analyzer includes:

- Standard two year warranty
- External pump
- Permeation air dryer for ozone generator air supply
- Independent NO, NO<sub>2</sub>, NO<sub>x</sub> ranges
- Auto ranging
- 47mm diameter particulate filter
- 8 digital status outputs, 6 inputs
- Dual bi-directional RS-232
- APIcom remote control software

### Specify input AC voltage & frequency:

- 100V - 115V     50Hz
- 220V - 240V     60Hz

### Specify output DC voltage:

- 10V     5V     1V     0.1V

### Calibration Options:

- Dual calibration valves for selection of customer-specified zero and span gas
- Internal zero and permeation tube oven for calibration check (requires permeation tube, available as option)
- Triple gas valve manifold

### Optional Equipment:

- Rack mount brackets (19") with chassis slides
- Rack mount brackets only
- 4-20mA outputs (specify up to three channels)

- Multi-drop RS-232 connection
- Ethernet port includes 7 ft. CAT-5 cable (disables one serial port)
- \* Permeation dryer for sample gas  
\*Required for EN14211 approved configuration
- Permeation dryer combination for ozone and sample air

### Accessories:

- RS-232 Cable
- Expendables Kit
- Spare Parts Kit
- Chassis carrying handle
- Zero Air Scrubber

Specifications subject to change without notice. Printed documents are uncontrolled. SAL000006 A (DCN 5058) M200E/08/08/08.



**TELEDYNE INSTRUMENTS**  
*Advanced Pollution Instrumentation*

A Teledyne Technologies Company

9480 Carroll Park Drive ■ San Diego, CA 92121-5201

Ph. 858-657-9800 Fax 858-657-9816

Email [api-sales@teledyne.com](mailto:api-sales@teledyne.com)

For more information about the Teledyne API family of monitoring instrumentation products, call us or visit our website at

[www.teledyne-api.com](http://www.teledyne-api.com)

