

MODEL T108
Total Sulfides in CO₂ Analyzer
Addendum to T100 Operation Manual, PN 06807

Also supports operation of:

Model T108U Analyzer

(when used in conjunction with both the T100 manual, PN 06807,
and the T100U addendum, PN 06840)

© TELEDYNE ADVANCED POLLUTION INSTRUMENTATION (TAPI)
9480 CARROLL PARK DRIVE
SAN DIEGO, CA 92121-5201
USA

Toll-free Phone:	800-324-5190
Phone:	858-657-9800
Fax:	858-657-9816
Email:	api-sales@teledyne.com
Website:	http://www.teledyne-api.com/

ABOUT THIS MANUAL

This T108 addendum is to be used in conjunction with the T100 operation manual. It also supports the T108U analyzer when used in conjunction with both the T100 manual and the T100U manual. This T108 addendum is comprised of the following documents:

Part No.	Rev	Name/Description
07268	A	T108 Addendum (this document)
06935	5/2/2011 15:12	T108 Spare Parts List
0626101	5/2/2011 15:18	M108E List, Expendables Kit
0626102	5/2/2011 15:27	M108EU List, Expendables Kit

NOTE

We recommend that this addendum and its accompanying manual(s) be read in its entirety before any attempt is made to operate the instrument.

REVISION HISTORY

T108 Addendum, PN 07268

2011 May 5				
Document	Part #	To Rev	DCN	Change Summary
T108 Addendum	07268	A	6083	Initial Release

This page intentionally left blank.

TABLE OF CONTENTS

TABLE OF CONTENTS.....	III
1 INTRODUCTION.....	5
1.1 Specifications and Warranty.....	5
1.2 The T108 Total Sulfides in CO ₂ Analyzer	6
1.3 Configurations	6
1.4 The M501TS – Total Reduced Sulfur Converter	10
1.5 Installation	12
1.6 Operation and Calibration	14
1.6.1 CO ₂ Source.....	14
1.7 TS and Zero Air Scrubbers.....	14
1.8 M501TS Temperature Controller	15
1.8.1 Changing the Temperature Set Point.....	15
1.8.2 Adjusting the P-I-D Parameters.....	16
2 TROUBLESHOOTNG.....	19
2.1 SO ₂ Analyzer Maintenance	21
2.2 Changing the Quartz Tube.....	23
2.3 Checking the Converter Efficiency	23
2.4 Sample Diluter Maintenance	24
2.5 Thermocouple Replacement.....	25
3 SPARE PARTS	29
3.1 Spare Parts and Expendables Lists	29
4 INSTRUMENT TEST & CALIBRATION RECORD.....	33

List of Figures

FIGURE 1-1. T108 BASIC CONFIGURATION	7
FIGURE 1-2. T108 WITH IZS/PERMEATION TUBE OPTION.....	8
FIGURE 1-3. T108 WITH M702 CALIBRATOR OPTION.....	9
FIGURE 1-4. M501TS CONVERTER LAYOUT.....	11
FIGURE 1-5. T108 PNEUMATIC CONNECTIONS	13
FIGURE 2-1. M501TS WIRING DIAGRAM	20
FIGURE 2-2. M501TS WIRING DIAGRAM, 220V SYSTEMS	22
FIGURE 2-3. DILUTER FLOW BLOCK ASSEMBLY	24
FIGURE 2-4. THERMOCOUPLE	25
FIGURE 2-5. QUARTZ TUBE CAVITY FOR THERMOCOUPLE.....	26
FIGURE 2-6. THERMOCOUPLE INSTALLED	26
FIGURE 2-7. TIE-WRAP HOLD-DOWN LOCATION	27

List of Tables

TABLE 1-1. M501TS CONVERTER SPECIFICATIONS	5
TABLE 1-2 THERMOCOUPLE TYPE DISTINCTIONS	10
TABLE 1-3. TEMPERATURE CONTROLLER – INITIAL SETTINGS	17
TABLE 1-4. TEMPERATURE CONTROLLER - SECONDARY MENU	18
TABLE 3-1. T108 SPARE PARTS LIST, PN06846	29
TABLE 3-2. T108 EXPENDABLES KIT, PN	32

TABLE 4-1. FINAL TEST AND CALIBRATION VALUES FOR T108 33
TABLE 4-2. TEST AND CALIBRATION VALUES FOR T108U 34
TABLE 4-3. TEST AND CALIBRATIONS VALUES W/ CO2 WHERE APPLICABLE 35

1 INTRODUCTION

The T108 consists of two major assemblies: a modified T100 SO₂ analyzer and an M501TS thermal converter. This manual addendum describes the specifics of the T108 Analyzer that differ from the T100 Analyzer.

1.1 Specifications and Warranty

The specifications and the warranty for the SO₂ analyzer are contained in the T100 manual.

The specifications for the M501TS Converter are presented in Table 1-1

Table 1-1. M501TS Converter Specifications

Specification	Value	Unit
Maximum Flow Rate	1000	cc/min
Nominal Flow Rate (CO ₂)	625	cc/min
Nominal Flow Rate (Air/N ₂)	450	cc/min
Maximum TS Concentration for specified conversion efficiency	20	ppmv
Minimum Conversion Efficiency (In CO ₂ matrix)		%
	H ₂ S 98	
	COS, CS ₂ 90	
Least Discernible Level (LDL)	See T100 Manual	
Operating Converter Temperature	1000	° C
Maximum Converter Temperature	1050	° C
Power	100-120/220-240 VAC 50/60 Hz, 440 watts	
Weight	24 (11)	lbs. (kg)
Dimensions	7 x 17 x 22 (178 x 432 x 559)	inches (mm)

1.2 The T108 Total Sulfides in CO₂ Analyzer

The Teledyne API Model T108 Total Sulfides in CO₂ Analyzer, is designed to measure mixed sulfur impurities, collectively referred to as Total Sulfides (TS), in carbon dioxide (CO₂) gas. Since there is no SO₂ scrubber in the system, the instrument reading is the sum of the reduced sulfur compounds and SO₂. The T108 consists of a modified T100 UV Fluorescence SO₂ Analyzer, with special software, and a M501TS high temperature quartz thermal converter.

The M501TS primarily consists of a heated, temperature-controlled quartz tube. Sulfur compounds are heated to approximately 1000 °C as they pass through the quartz tube and are converted to SO₂ in the following manner:

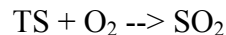

Since the gas being analyzed is essentially CO₂, which generally contains no oxygen, the analyzer includes an oxygenator to add approximately 6% oxygen to the sample before it passes through the converter. This dilution of the sample gas is compensated by the software and calibration procedure. The added oxygen allows the sulfur compounds to be oxidized to SO₂ making the T108 respond to the total number of sulfur molecules in the sample gas. Any SO₂ present in the sample is unaffected by the converter and adds to the measured concentration. The sample gas then passes to a modified T100 analyzer where the SO₂ and converted compounds are analyzed as SO₂.

1.3 Configurations

There are three configurations available: the standard analyzer and two with options.

The standard unit consists of:

- modified T100 Fluorescent SO₂ Analyzer
- M501TS High Temperature Thermal Converter
- External Span, Internal Zero with High-performance Charcoal Scrubber for Zero.

See Figure 1-1 for the pneumatic diagram, and Section 1.4 for details on operation of the M501TS.

Another configuration consists of:

- standard unit (described above)
- Internal Zero/Span (IZS) Option with H₂S permeation tube.

The IZS option uses sample gas (passed through a special, high-performance charcoal scrubber) to dilute H₂S from the perm tube for span calibration checks. See Figure 1-2 for the pneumatic diagram.

The third configuration consists of:

- standard unit (described above)
- external M702 calibrator

The M702 calibrator option blends tanks of H₂S span gas with the processed CO₂.

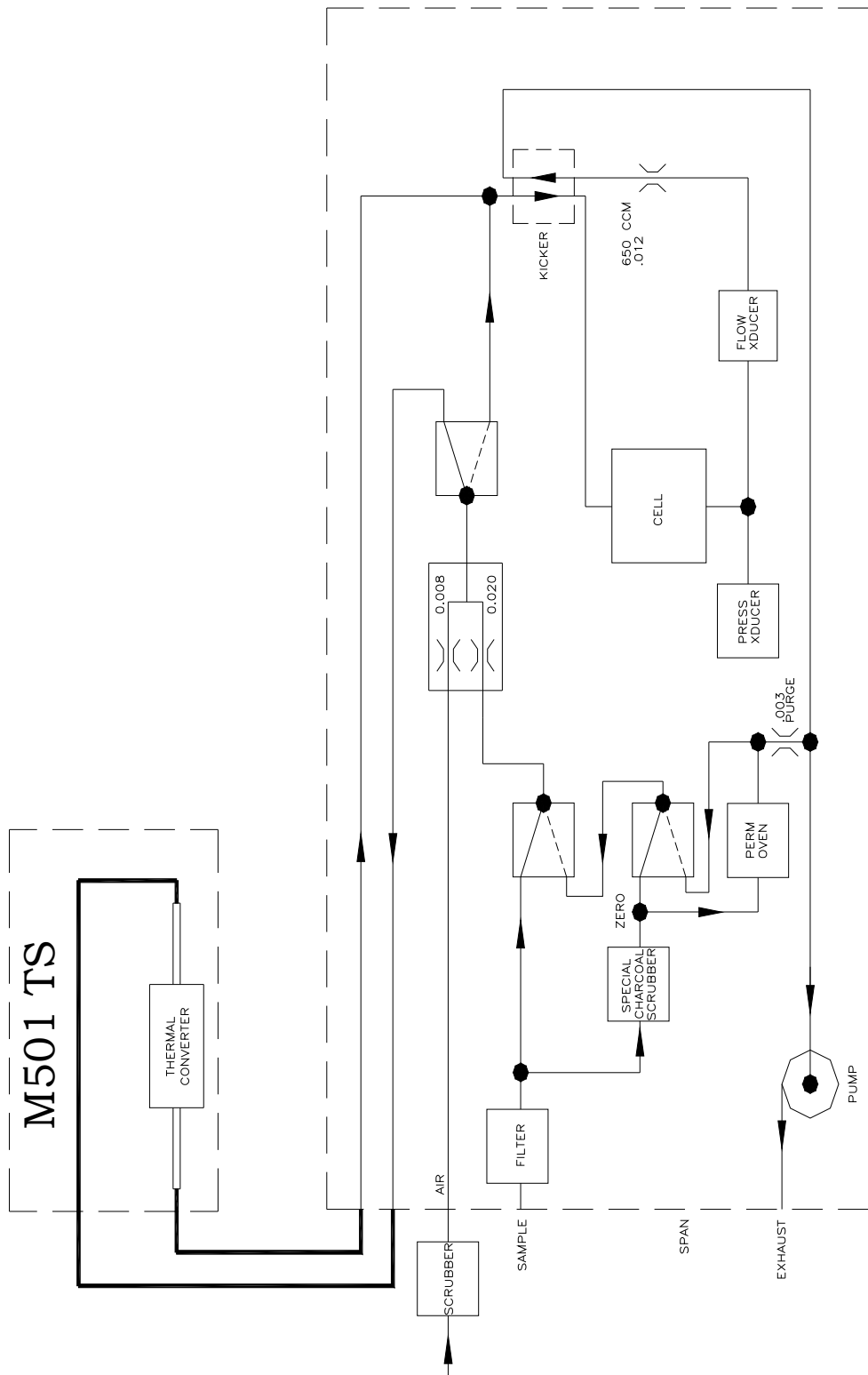

Figure 1-2. T108 with IZS/Permeation Tube Option

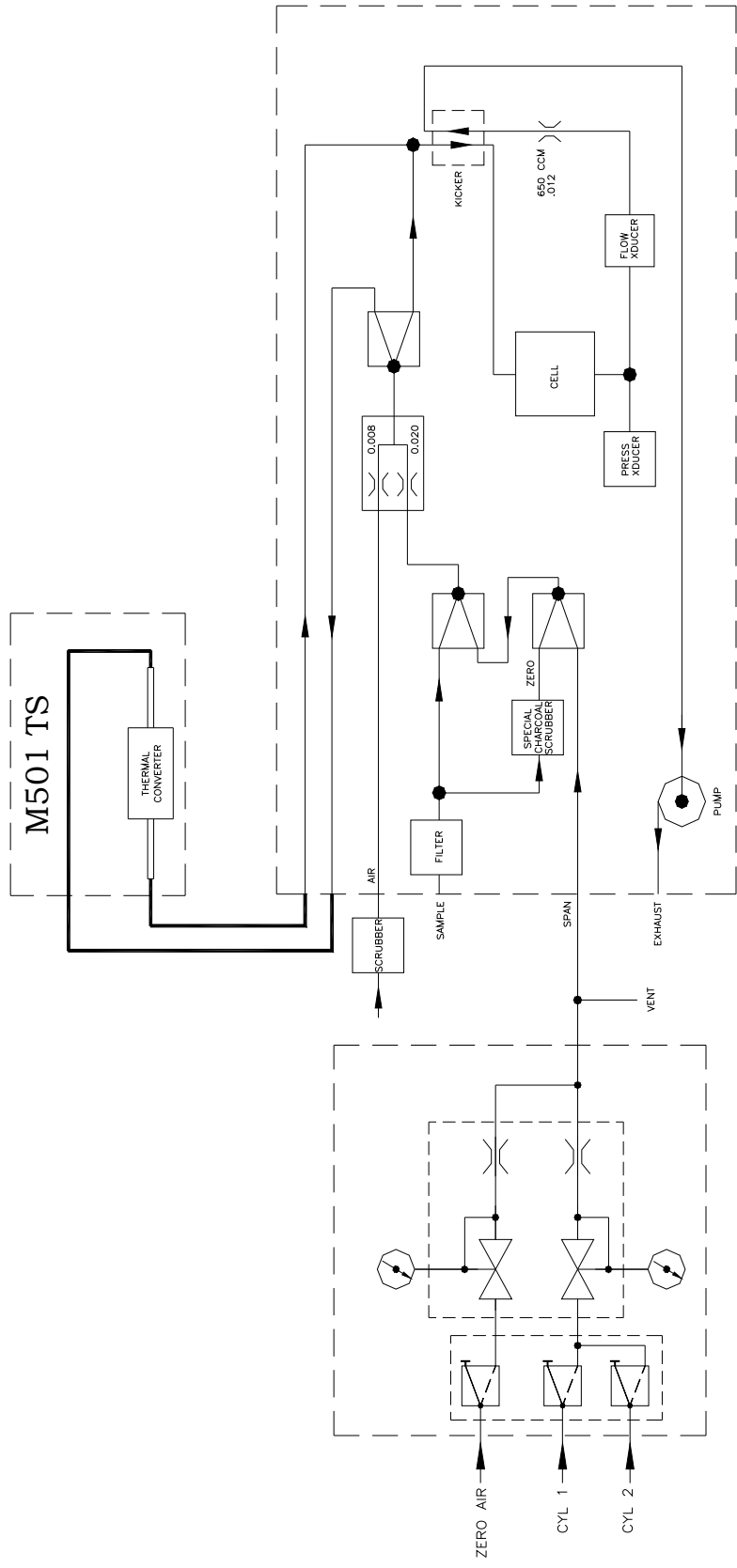

Figure 1-3. T108 with M702 Calibrator Option

1.4 The M501TS – Total Reduced Sulfur Converter

The M501TS oxidizes reduced sulfur compounds to SO₂ in a high temperature quartz oven. A front-panel-mounted, programmable digital temperature controller regulates power to the heater. Power to the heater is switched by a solid state, zero-crossing relay. An over/under-temperature alarm contact closure is located on the rear panel. The alarm set point is adjustable in the temperature controller. The heater temperature is sensed by a Type S (distinguished from other thermocouple types by its wire colors, red and black; see table below) (Platinum-Rhodium) thermocouple probe inserted in the bore alongside the quartz tube. Note: If using a type K or N thermocouple, or if switching to a type S thermocouple, please refer to Sections 1.8 and 2.5 for proper controller configuration.

The quartz tube carrying the sample mixture runs through the core of the heater and is heated by radiation from electrical heating elements at the heater bore surface. See Figure 1-4 for a layout view of the converter.

Table 1-2. Thermocouple Type Distinctions

Thermocouple Type	Indicated by Wire Color
S	red and black
K	red and yellow
N	red and orange



WARNING !
ENSURE PROPER LINE VOLTAGE IS SELECTED PRIOR TO PLUGGING UNIT INTO POWER SOURCE.



CAUTION!
THE QUARTZ TUBE AND HEATER ARE VERY HOT DO NOT TOUCH



CAUTION!
ENSURE THAT YOU SELECT THE CORRECT SETTING) FOR THE THERMOCOUPLE TYPE THAT YOU HAVE! (see Table 1-4

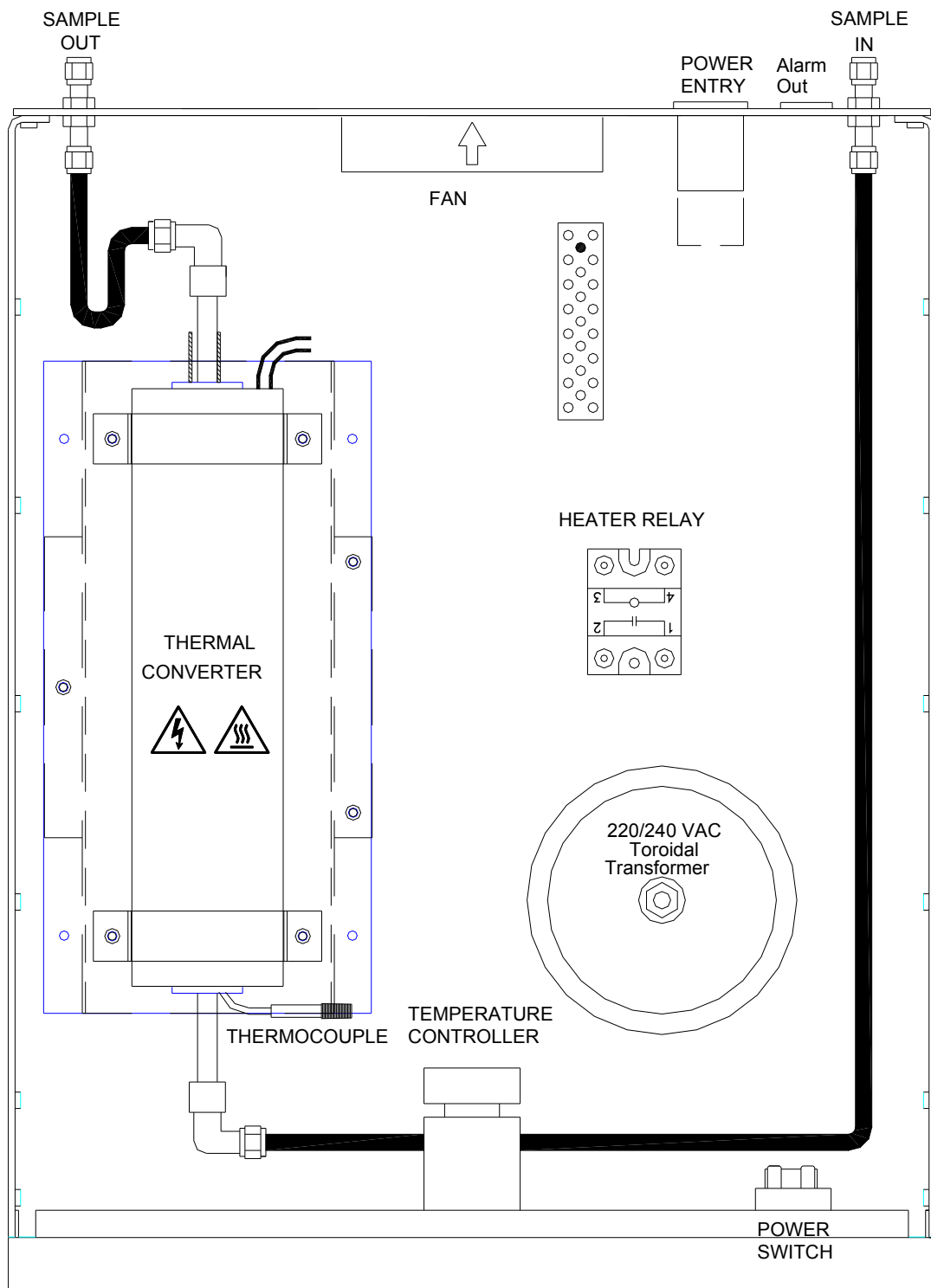

Figure 1-4. M501TS Converter Layout

1.5 Installation

The T108 consists of two chassis. There is a power cord for each that should be plugged into the correct AC mains receptacle. See the model label on the rear panel of each chassis for the voltage and frequency configuration. The power connection must be made with an approved three-wire-grounded power cord.

The pneumatic connections are shown in Figure 1-5 .

- Connection to the TS analyzer must be made with Teflon tubing.
- Connect the sample inlet to the labeled fitting.
- The sample exhaust must be routed to a well-ventilated area away from the air inlet for the zero air scrubber on the rear panel.



CAUTION !
DO NOT BLOCK THE SIDE AND BACK
VENTILATION OF THE M501TS CONVERTER

The overall pneumatic diagrams of the Model T108 are shown in Figure 1-1, Figure 1-2 , and Figure 1-3.



CAUTION !
DO NOT OPERATE WITHOUT THE COVER OF THE
M501TS CONVERTER INSTALLED

OVEN TEMPERATURE WILL NOT REGULATE
PROPERLY WITHOUT THE COVER IN PLACE

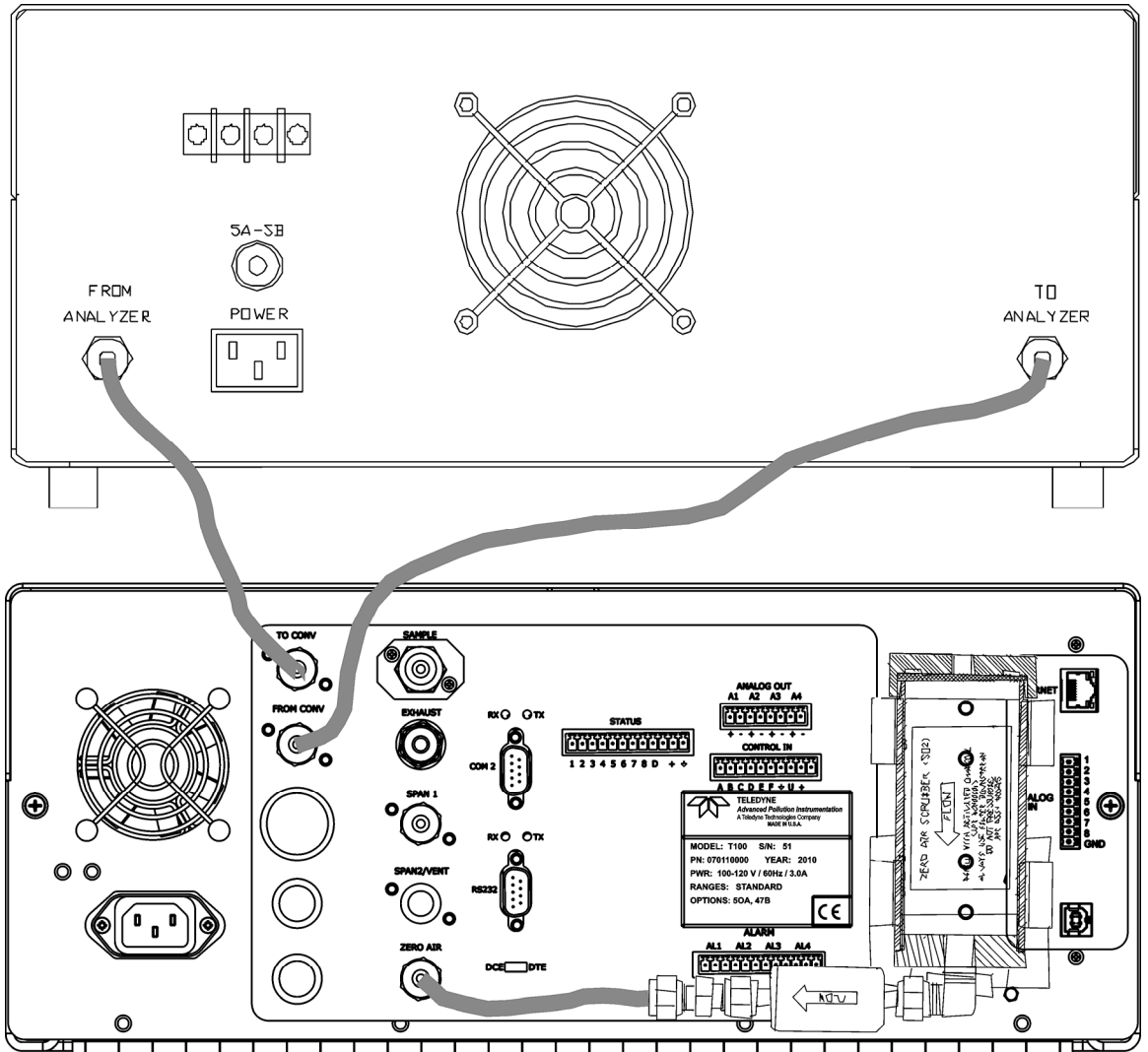

Figure 1-5. T108 Pneumatic Connections

1.6 Operation and Calibration

Refer to the T100 manual for the overall operation of the SO₂ analyzer. This unit has some unique operating characteristics and calibration procedures detailed below.

The basic purpose of this instrument is to analyze CO₂ sample gas for sulfur containing impurities. Typically the impurities should be at low levels; therefore it is especially important that the zero calibration of the analyzer is done accurately so that even small levels of impurities can be detected.

1.6.1 CO₂ Source

A source of CO₂ that is free of sulfides is required for accurate zero calibration of the instrument. If the 'zero gas' used to zero the instrument is contaminated, the process gas will read artificially low, sometimes even showing a negative TS concentration. Standard CO₂ bottles can have unacceptably high levels of sulfur compounds in them. Beverage grade CO₂ should be used as a diluent as well as the 'zero gas' source for calibration of the T108.

Since CO₂ strongly quenches the SO₂ fluorescence reaction, the instrument sensitivity will be greatly reduced when using CO₂ as the balance gas. Therefore it is imperative that the T108 be calibrated using CO₂ as the balance gas when it will be measuring TS in a gas matrix that is primarily CO₂.

CO₂ liquefies when compressed, and sulfur compounds do not stay dissolved in liquid CO₂. Therefore it is not practical to use compressed gas bottles of H₂S in CO₂ for calibration purposes. TAPI strongly recommends that H₂S in N₂ bottles be used for calibration of the T108, and that a calibrator be used to mix zero gas (CO₂) into the cal gas stream, making the final calibration gas mostly CO₂.

1.7 TS and Zero Air Scrubbers

There are two charcoal scrubbers in the analyzer chassis of the T108. The scrubber canister on the outside of the rear panel of the analyzer is a standard charcoal scrubber that supplies zero air for the diluter assembly. The second scrubber is located inside the analyzer behind the sample filter. This scrubber uses a specially impregnated charcoal (TAPI Part# CH_52) which is especially effective in scrubbing TS gasses. This filter is used to scrub TS from the inlet sample gas for use in zero calibrating the analyzer.

1.8 M501TS Temperature Controller

A front-panel-mounted, programmable controller maintains the heater temperature. The “Fuji Electric PXZ Series Operation Manual” is included with the documentation for this instrument. The controller has been set up at the factory. Should further adjustments be necessary, set-up instructions are briefly stated in Section 1.8.1.

To view the actual temperature, PV – Present Value, or the set point value, SV – Set-point Value, press the PV/SV button in the lower left corner of the controller.

1.8.1 Changing the Temperature Set Point

The temperature can be adjusted to temperatures other than 1000 °C. However, TAPI recommends that the converter always be left at the nominal temperature of 1000 °C. The converter has not been tested for conversion efficiency or reliability at other temperatures, and TAPI does not guarantee warranty support or that the converter will meet published specifications if the operating temperature is changed. To adjust the operating temperature:

1. Select **SV** with the PV/SV button,
2. Select the Set-Point value at approximately 1000 °C by pressing the "up-arrow" under the digit you want to change, (the digit will flash).

NOTE:
DO NOT SET THE TEMPERATURE HIGHER THAN 1050°C

3. Press the "up-arrow" under the digit or the "down-arrow" at the left to scroll the digit to the desired value.
4. Repeat for each digit.
5. Press the ENTER button.
6. Select **PV** with the PV/SV button to observe the actual temperature. Allow temperature to equilibrate for a minimum of 30 to 45 minutes.

1.8.2 Adjusting the P-I-D Parameters

In the event that the control parameters must be changed or in the event that a new controller is installed, it must be reprogrammed to suit the thermal characteristics of the instrument. It is recommended that the Auto Tune function be used to set the control functions if reprogramming is necessary.

The following table is a guide to the approximate values for setting the parameters that will produce the initial settings for the auto-tune function. Below is a summary of the auto-tune procedure, refer to the Fuji Manual for more detailed information.

1.8.2.1 Auto-Tune

To perform the Auto Tune function:

1. Set the SV to the desired temperature.
2. Set the parameter A7 to 1.
3. Press ENTER.

The controller will begin the auto-tune process, which takes several minutes. The decimal point at the lower right of the display will blink, indicating the controller is auto-tuning. During the process, the temperature may oscillate $\pm 100^{\circ}\text{C}$ or more. When the process is completed, the decimal point will stop blinking.

NOTE:

It is normal for the ceramic heating element to emit a red glow at the operating temperature.

Table 1-3 includes typical values for a converter set up for operation on 115V/60Hz. The P, I and d values may be different for individual converters and AC mains voltages, and will vary somewhat after auto-tuning.

Table 1-3. Temperature Controller – Initial Settings

PRESS	DISPLAY	INITIAL VALUE
SEL	P PROP BAND	UP/DOWN SET TO “11”
SEL	I INTEGRAL	SET TO “10”
SEL	d DERIVATIVE TIME	SET TO “7.7”
SEL	AL LOW ALARM SETPOINT	SET TO “50” (°C BELOW FINAL SETVALUE)
SEL	AH HIGH ALARM SETPOINT	SET TO “50” (°C ABOVE FINAL SETVALUE)
SEL	7C CYCLE TIME	SET TO “2”
SEL	HYS HYSTERESIS	SET TO “3”
SEL	A7 AUTOTUNE	SET TO “0” (OFF)
SEL	LOC LOCK	“0” (OPEN) “1” (LOCKED) “2” (SV ONLY OPEN)

Table 1-4 shows a Secondary Menu of parameters that set more basic parameters of the controller, these include the thermocouple type, the temperature units etc.

	<p>CAUTION – Avoid Damage to the Instrument</p> <p>Use only the “p-n2” setting specified for the specific thermocouple Type as described in Table 1-4 for “p n2”. If in doubt about which thermocouple Type you have, please contact Teledyne API Customer Service.</p>
---	--

Table 1-4. Temperature Controller - Secondary Menu

<u>PRESS</u>	<u>DISPLAY</u>	<u>PARAMETER VALUE</u>
SEL	HOLD TILL p-n1	SET TO “0”
SEL	p-n2* * Set only to the value stated in the next column.	Type S thermocouple (red & black wires): SET TO “6” In the rare event that you have a different thermocouple: Type K, red and yellow wires, SET TO “3” Type N, red and orange wires, SET TO “12”. CAREFULLY FOLLOW THE INSTALLATION INSTRUCTIONS PROVIDED IN SECTION 2.5 OF THIS MANUAL.
SEL	p-dF DIGITAL FILTER	SET TO “5”
SEL	P-SL LOWER LIMIT	SET TO “32” (32C)
SEL	P-SU UPPER LIMIT	SET TO “1050” (1050C)
SEL	P-AL ALARM TYPE2	SET TO “10”
SEL	P-AH ALARM TYPE 1	SET TO “10”
SEL	P-An HYTERESIS	SET TO “3”
SEL	P-dP DECIMAL LOCATION	SET TO “0”
SEL	PVOF PROCESS OFFSET	LEAVE AT “0”
SEL	SVOF SET POINT OFFSET	LEAVE AT “0”
SEL	P-F	SET TO “C” (CENTIGRADE)
SEL	FUZZY FUZZY LOGIC	SET TO “ON”

2 TROUBLESHOOTING

NO POWER:

Plugged in?
Switched on?
Circuit breaker Tripped?

NOT HEATING:

PV/SV switch to PV. Is it heating?
PV/SV switch to SV. Set point correct?
Socket in place on back of temperature controller?
Check M501TS wiring diagram Figure 3.1
Thermocouple has failed? 'UUUU' shown on front panel of 501TS. Also, check thermocouple resistance.

TS ANALYZER UNSTABLE:

Leak-check.
(Pressurize and see if pressure falls.
Use soap bubble to find leak.)

EFFICIENCY <90%:

Leaking? Leak-check.
Plugged? Compare flow through and bypassing converter.
Flow too high?
Set-point temperature optimized?
Span gas correct?
Contaminated? Check inside of Teflon tubing.

CONVERTER TEMP UNSTABLE: Perform Auto-Tune procedure in Section 1.8.2.1.

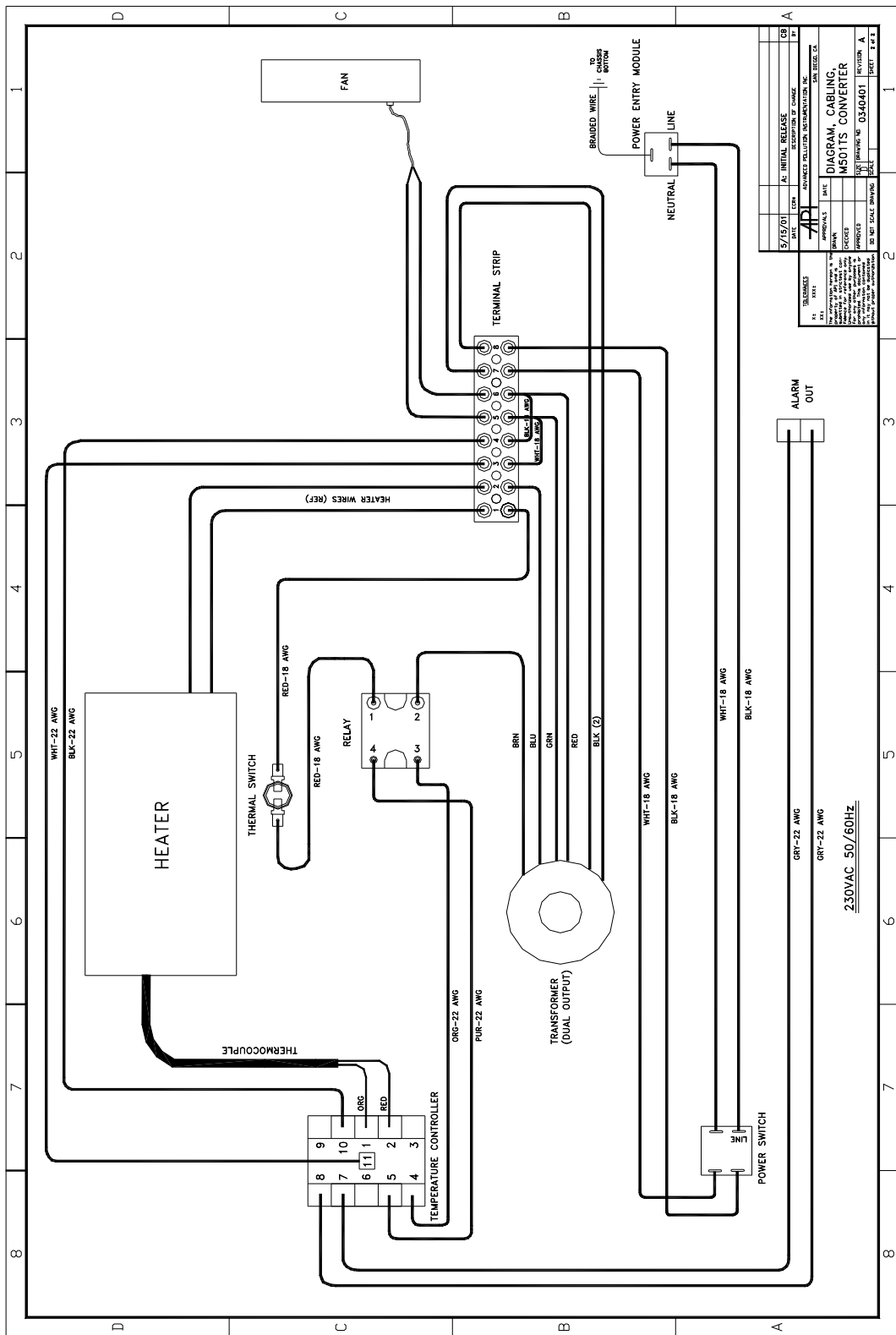

DATE	5/15/01	BY	AP
DESCRIPTION	INITIAL RELEASE	REV	01
APPROVALS	DATE	BY	REV
DESIGNED BY	ADVANCED ELECTRONICS CORPORATION, INC.	SCALE	SEE DETA.
CHECKED BY			
TESTED BY			
APPROVED BY			
PROJECT NO.	0340401	REVISION	A
DO NOT SCALE DRAWING			

Figure 2-1. M501TS Wiring Diagram, 220V

2.1 SO₂ Analyzer Maintenance

Maintenance of the SO₂ analyzer is covered in the Maintenance section of its respective manual. Unlike the T100, the T108 has one standard charcoal scrubber on the rear panel of the SO₂ analyzer instrument chassis, and another special charcoal scrubber inside the chassis. The zero calibration (and thus the overall accuracy of the instrument) is dependent on high quality zero air. **Make sure that the charcoal is replaced at the 3-month interval suggested in the T100 maintenance schedule. Also be sure not to mix charcoal between the inner and outer scrubber canisters, they are different materials.**

2.2 Changing the Quartz Tube

1. Turn off M501TS and allow it to cool to room temperature (~2 hours).
2. See Figure 2.4. – M501TS Layout
3. Remove the screws from the top inside of the front panel and fold panel downward.
4. Loosen front and rear fittings at each end of the tube.
5. Carefully slide the tube out of the heater – the ceramic bushings at each end of the heater are very fragile.
6. Slide the new tube into the heater, and re-connect the fittings.
7. Leak check the unit.
8. Replace the thermocouple making sure that it is fully inserted into the indentation in the body of the quartz tube.
9. Check the converter efficiency. See Section 4.3

2.3 Checking the Converter Efficiency

After maintenance it is good practice to check the converter efficiency. To check the converter efficiency, perform the following procedure:

1. Produce a calibration gas of 400 ppb H₂S in CO₂ at a flow greater than the demand of the instrument; vent the excess gas out of the room.
 - When using a calibrator or gas blender to generate H₂S span gas (either permeation tube or tank) with CO₂ gas as the diluent, please remember that rotameters and mass flow controllers are calibrated with air or nitrogen. Using them with CO₂ will produce large calibration errors (as large as 30% or more), since CO₂ gas has considerably different characteristics. Contact the manufacturer of your mass flow measurement/control device for instructions on how to use it to measure CO₂ flow. Or use a flowmeter such as a soap bubble, or BIOS – DryCal flowmeter that measures volume flow
2. Allow the T108 to stabilize at span for at least 30 minutes.
3. Check the converter efficiency by adjusting the converter's temperature controller set point:
 - Starting at the converters normal set-point of 1000 °C, lower the set-point temperature of the Converter in 5 °C increments (allowing 10 minutes minimum settling time between increments) until a drop of approximately 5% of Full Scale is observed. Note the Thermal Converter temperature at this point.
 - Verify that the converter efficiency does not drop by 5% until the temperature has dropped by at least 40 °C,
 - Return the temperature set point to 1000 °C.

2.4 Sample Diluter Maintenance

The sample diluter is used to inject a small amount of ambient air into the sample stream to provide oxygen for the converter. The diluter is located on the inside rear panel of the SO₂ analyzer. It consists of a stainless steel block and 2 orifices to control the amount of sample and air that is blended.

There should be no periodic maintenance required on this assembly, but a diagram is included in case rebuilding of this assembly is required. The assembly is shown in Figure 3.3.

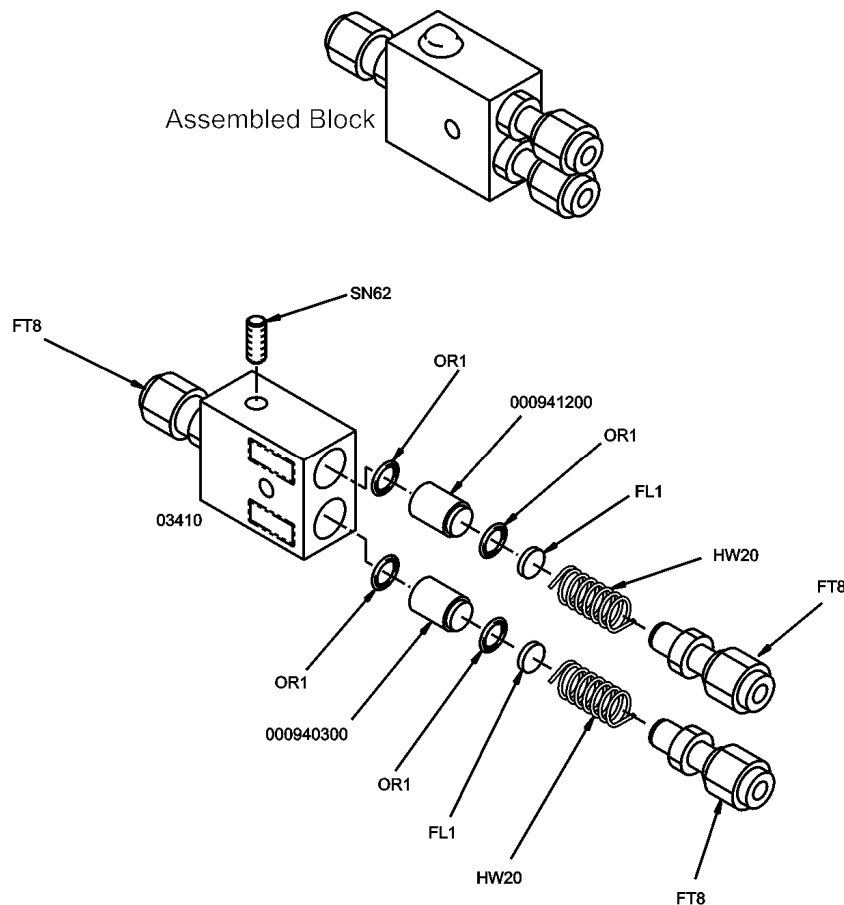

Figure 2-3. Diluter Flow Block Assembly

2.5 Thermocouple Replacement

Continuous operation at 1000 °C will eventually degrade the performance of the thermocouple used to sense the temperature of the quartz oven. The following instructions describe how to install a new thermocouple into the Converter Heater Block. This is a replacement thermocouple (KIT000255). The following instructions provide the necessary information to remove the existing thermocouple and replace it with the new one supplied in Kit 255.

You will need the following tools:

- Nutdriver, $\frac{5}{16}$
- Nutdriver, $\frac{11}{32}$
- Diagonal Cutter
- Philips head Screwdriver #2

You must obtain the following replacement parts kit from T-API:

- KIT000255 (AKIT, Retrofit, M501TS, TC Type S RPLCMN)

Once you have the right tools and parts, replace the thermocouple as follows:

1. Ensure power is removed from the M501TS Converter. If the Converter has been operational you will need to wait for 2 hours for the Converter oven to cool before continuing with the replacement of the thermocouple.
2. Remove the cover from the Converter chassis.
3. Unscrew the (4) nuts that secure the front panel to the chassis. They are located just behind the Front Panel along the top.
4. Lower the Front Panel to gain easier access to the end of the quartz tube.
5. Unscrew the (3) nuts that secure the inner cover protecting the Heater Block and quartz tube. Remove this cover.
6. Cut the tie-wrap that secures the thermocouple to the fitting at the end of the quartz tube.
7. Loosen the Teflon fitting at the end of the quartz tube taking care not to put any stress on the tube, and slide the fitting off the tube.
8. Remove the thermocouple.
9. Disconnect the thermocouple wires from the Temperature Controller.

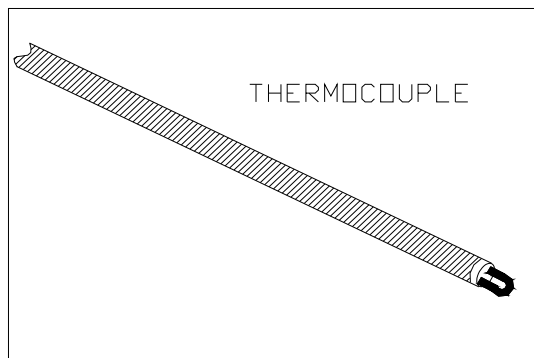

Figure 2-4. Thermocouple

10. In preparation for installing the new thermocouple, look into the end of the Heater Block. You will see that there is an indentation (cavity) in the fat part of the quartz tube. This is where the thermocouple you are installing will reside. Refer to Figure 2-5.

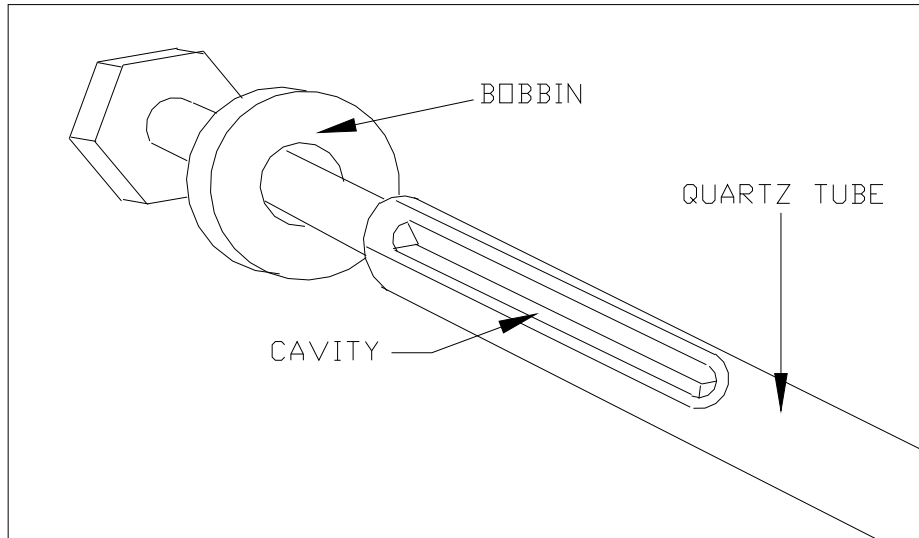

Figure 2-5. Quartz Tube Cavity for Thermocouple

11. The thermocouple should slide into the Heater Block and into the indentation of the quartz.
12. Align the thermocouple with this cavity and carefully push the thermocouple all the way into the cavity until it comes to a stop, which is the end of the cavity of the quartz tube.
13. The thermocouple should now be properly seated in the cavity of the quartz tube. Refer to Figure 2-6

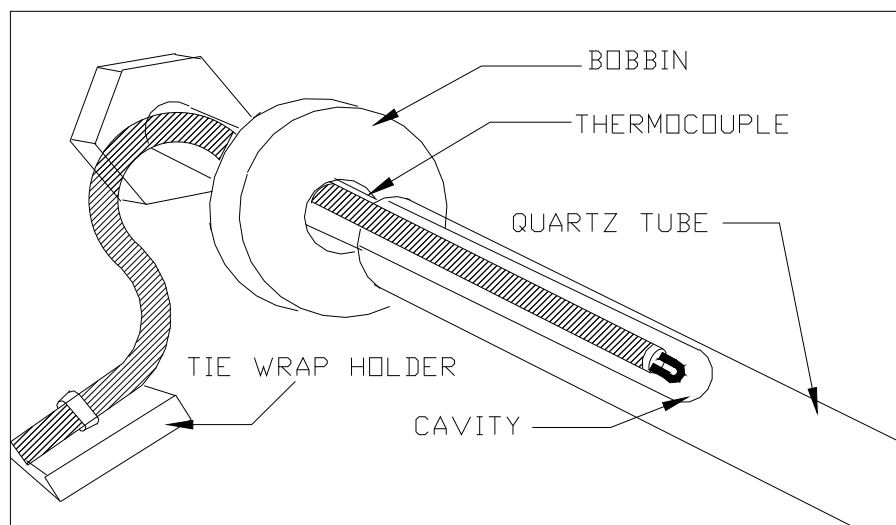

Figure 2-6. Thermocouple Installed

14. Reconnect the Teflon fitting that was removed earlier from the end of the quartz tube. Take care not to put any stress on the quartz tube as the Teflon fitting is tightened.
15. Clean the chassis where the Tie-Wrap Hold-Down will be placed (alcohol is recommended), and place the Tie-Wrap Hold-Down as shown in the Figure 2-7.

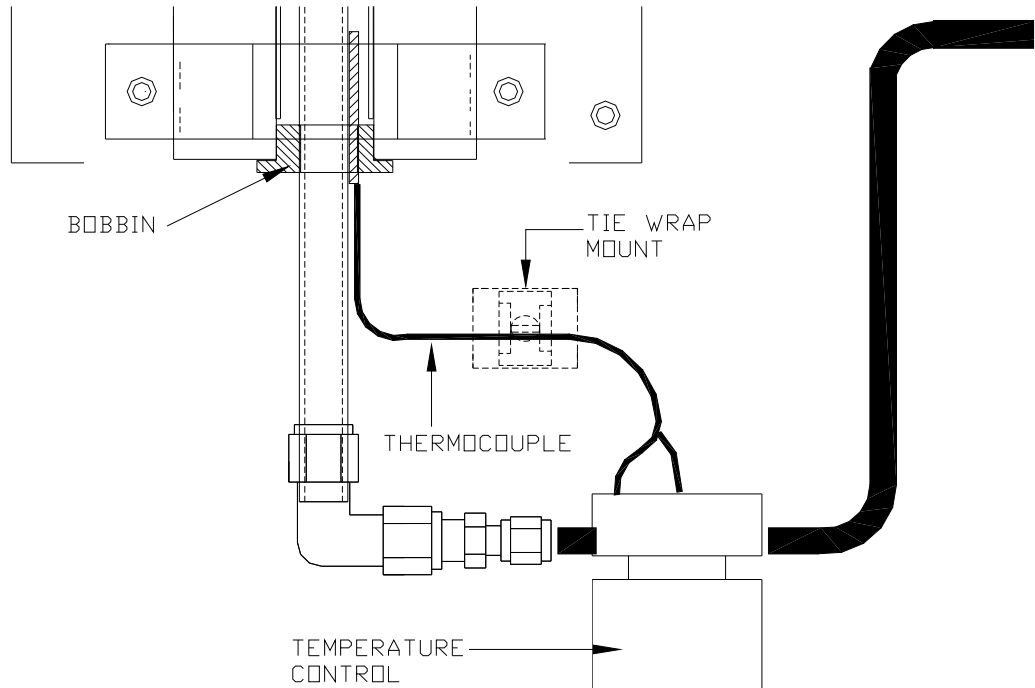

Figure 2-7. Tie-Wrap Hold-Down Location

16. Form the Thermocouple wire so that it rests in the cavity with little movement.
17. Connect the (2) wires of the thermocouple to the Temperature Controller. The Black wire should be connected to Pin 1 and the Red wire should be connected to Pin 2. (If the wires are of any other color, STOP. Get the correct part from T-API Sales or call Customer Service).
18. At this point, all connections have been made, both electrically and pneumatically. A leak check should be performed on the Converter to verify that all connections are leak free. If a leak is detected, the leak should be resolved before continuing.
19. Install the inner cover of the Heater Block and secure with the (3) nuts. Close the Front Panel and secure with the (4) nuts. Install the top cover on the Converter chassis.
20. The Converter is now ready for the application of power. You will be looking for an indication from the temperature controller that it is functioning correctly and driving the heater to the desired “set” temperature. Apply power now.
21. Check the Temp Controller to be sure that it knows which type of Thermocouple it has in it. Follow the directions in Section 1.8.2 of this

- document, paying particular attention to the settings in Table 2-5 to be sure that the temp controller is set properly.
22. After the Converter comes to the regulated temperature, perform the Auto Tune function (see Section 1.8.2.1) to tune the Temperature Controller to the new thermocouple. .
 23. After the Auto-Tune process is completed, verify that the “process” temperature is indicating that the desired temperature is stable and being regulated.

The converter is now ready for operation.

3 SPARE PARTS

This section presents the Spare Parts Lists for the T108 and the T108U. For T100 Spare Parts or Expendables, please refer to the respective manual. Also, please refer to our Website or call Sales for more recent updates to these lists.

Please note that the internal scrubber cartridge takes a special scrubber material. TAPI's standard Sox scrubber material is not appropriate for use in the internal scrubber assembly. The external scrubber does take standard scrubber material.

3.1 Spare Parts and Expendables Lists

Please check the Teledyne API website or Sales for the most recent updates to the lists.

Table 3-1. T108 Spare Parts List, PN06935 (Reference: 5/2/2011 15:12)

PARTNUMBER	DESCRIPTION
000940100	CD, ORIFICE, .003 GREEN
000940300	CD, ORIFICE, .020 VIOLET
000940400	CD, ORIFICE, .004 BLUE
000940800	CD, ORIFICE, .012 (NO PAINT)
000941200	CD, ORIFICE, .008, RED/NONE
002690000	CD, LENS, PL-CON (KB)
002700000	CD, LENS, BI-CON (KB)
002720000	CD, FILTER, 330NM (KB)
003290000	THERMISTOR, BASIC (VENDOR ASSY)(KB)
005960000	AKIT, EXP, 6LBS ACT CHARCOAL (2 BT=1)
009690000	AKIT, TFE FLTR ELEM (FL6 100=1) 47mm
009690100	AKIT, TFE FLTR ELEM (FL6, 30=1) 47mm
011630000	HVPS INSULATOR GASKET (KB)
012720100	OPTION, NOx OPTICAL FILTER *
013140000	ASSY, COOLER FAN (NOX/SOX)
013210000	ASSY, VACUUM MANIFOLD
013390000	ASSY, KICKER
013400000	CD, PMT, SO2, (KB)
013420000	ASSY, ROTARY SOLENOID
013570000	THERMISTOR HOUSING ASSY SOX/NOX(KB)
014080100	ASSY, HVPS, SOX/NOX
014400100	OPTION, ZERO AIR SCRUBBER
014750000	AKIT, EXP KIT, IZS
016290000	WINDOW, SAMPLE FILTER, 47MM (KB)
016300700	ASSY, SAMPLE FILTER, 47MM, ANG BKT
029580000	ASSY, XFMR, 230V/115V 400VA
037100000	TUBE, CONVERTER (KB)
037310000	ASSY, DILUTION FLOW CONTROL BLOCK
037340100	ASSY, ZERO AIR SCRUBBER (TS), SHORT CAN

PARTNUMBER	DESCRIPTION
037860000	ORING, TEFLON, RETAINING RING, 47MM (KB)
040010000	ASSY, FAN REAR PANEL
040030100	PCA, PRESS SENSORS (1X), w/FM4
040031100	PCA, FLOW SENSOR
041620100	ASSY, SO2 SENSOR (KB)
041800400	PCA, PMT PREAMP, VR
042410200	ASSY, PUMP, INT, SOX/O3/IR *
043420000	ASSY, HEATER/THERM, O2 SEN
043570000	AKIT, EXPENDABLES
045230200	PCA, RELAY CARD
046250000	ASSY, RXCELL HEATER/FUSE
046260000	ASSY, THERMISTOR, RXCELL (KB)
049310100	PCA, TEC DRIVER, PMT, (KB)
050610100	OPTION, 100-120V/60Hz (KB)
050610200	OPTION, 100-120V/50Hz (KB)
050610300	OPTION, 220-240V/50Hz, (KB)
050610400	OPTION, 220-240V/60Hz (KB)
050610500	OPTION, 100V/50Hz, (OBS)
050610600	OPTION, 100V/60Hz (OBS)
050630100	PCA, REF DET w/OP20, DUAL OUT
052660000	ASSY, HEATER/THERM, IZS
055100200	ASSY, OPTION, PUMP, 240V *
055560000	ASSY, VALVE, VA59 W/DIODE, 5" LEADS
058021100	PCA, MOTHERBD, GEN 5-ICOP
059220000	THERMOCOUPLE, TYPE S, ALUMINA SHEATH
061930000	PCA, UV LAMP DRIVER, GEN-2 43mA *
066970000	PCA, INTRF. LCD TOUCH SCRIN, F/P
067240000	CPU, PC-104, VSX-6154E, ICOP *(KB)
067300000	PCA, AUX-I/O BD, ETHERNET, ANALOG & USB
067300100	PCA, AUX-I/O BOARD, ETHERNET
067300200	PCA, AUX-I/O BOARD, ETHERNET & USB
067900000	LCD MODULE, W/TOUCHSCREEN(KB)
068810000	PCA, LVDS TRANSMITTER BOARD
069430100	DOM, w/SOFTWARE, T108*
069500000	PCA, SERIAL & VIDEO INTERFACE BOARD
072150000	ASSY. TOUCHSCREEN CONTROL MODULE
072800000	KIT, T108 MANUAL
CN0000073	POWER ENTRY, 120/60 (KB)
CN0000458	PLUG, 12, MC 1.5/12-ST-3.81 (KB)
CN0000520	PLUG, 10, MC 1.5/10-ST-3.81 (KB)
CP0000035	CONTROLLER, TEMP, FUJI, PXR
FL0000001	FILTER, SS (KB)
FL0000003	FILTER, DFU (KB)
FM0000004	FLOWMETER (KB)
HE0000007	CERAMIC HEATER, 220W@60V
HW0000005	FOOT

PARTNUMBER	DESCRIPTION
HW0000020	SPRING
HW0000030	ISOLATOR
HW0000031	FERRULE, SHOCKMOUNT
HW0000036	TFE TAPE, 1/4" (48 FT/ROLL)
HW0000101	ISOLATOR
HW0000416	COVER, CRYDOM RELAYS, RL9, 19 & 20
HW0000453	SUPPORT, CIRCUIT BD, 3/16" ICOP
HW0000685	LATCH, MAGNETIC, FRONT PANEL
KIT000093	AKIT, REPLCMNT(3187)214NM FLTR (BF)
KIT000095	AKIT, REPLACEMENT COOLER
KIT000219	AKIT, 4-20MA CURRENT OUTPUT
KIT000236	KIT, UV LAMP, w/ADAPTER (BIR)
KIT000253	ASSY & TEST, SPARE PS37
KIT000254	ASSY & TEST, SPARE PS38
KIT000255	AKIT, RETROFIT, M501TS, TC TYPE S RPLCMN
OP0000031	WINDOW, QUARTZ, 1/2"DIA, .063" THICK (KB)
OR0000001	ORING, 2-006VT *(KB)
OR0000004	ORING, 2-029V
OR0000006	ORING, 2-038V
OR0000007	ORING, 2-039V
OR0000015	ORING, 2-117V
OR0000016	ORING, 2-120V
OR0000025	ORING, 2-133V
OR0000027	ORING, 2-042V
OR0000039	ORING, 2-012V
OR0000046	ORING, 2-019V
OR0000083	ORING, 105M, 1MM W X 5 MM ID, VITON
OR0000084	ORING, 2-020V
OR0000094	ORING, 2-228V, 50 DURO VITON(KB)
PU0000022	REBUILD KIT, FOR PU20 & 04241 (KB)
RL0000015	RELAY, DPDT, (KB)
RL0000020	SSRT RELAY, TD2410, CE MARK
SW0000025	SWITCH, POWER, CIRC BREAK, VDE/CE *(KB)
SW0000040	PWR SWITCH/CIR BRK, VDE CE (KB)
SW0000058	SWITCH, THERMAL/450 DEG F(KB)
SW0000059	PRESSURE SENSOR, 0-15 PSIA, ALL SEN
WR0000008	POWER CORD, 10A(KB)

Table 3-2. M108E Expendables Kit, PN062610100 (Reference: 5/2/2011 15:18)

PARTNUMBER	DESCRIPTION
005960000	AKIT, EXP, 6LBS ACT CHARCOAL (2 BT=1)
009690100	AKIT, TFE FLTR ELEM (FL6, 30=1) 47mm
018080000	AKIT, DESSICANT BAGGIES, (12)
039620100	AKIT, EXP KIT, IMPREG CHARCOAL, TS,
FL0000001	FILTER, SS (KB)
HW0000020	SPRING
NOTE01-23	SERVICE NOTE, HOW TO REBUILD KNF PUMP
OR0000001	ORING, 2-006VT *(KB)
PU0000022	REBUILD KIT, FOR PU20 & 04241 (KB)

Table 3-3. M108EU Expendables Kit, PN062610200 (Reference 5/2/2011 15:27)

PARTNUMBER	DESCRIPTION
005960000	AKIT, EXP, 6LBS ACT CHARCOAL (2 BT=1)
009690300	AKIT, TFE FLTR ELEM (FL19, 30=1) 47mm
018080000	AKIT, DESSICANT BAGGIES, (12)
039620100	AKIT, EXP KIT, IMPREG CHARCOAL, TS,
FL0000001	FILTER, SS (KB)
HW0000020	SPRING
NOTE01-23	SERVICE NOTE, HOW TO REBUILD KNF PUMP
OR0000001	ORING, 2-006VT *(KB)
PU0000022	REBUILD KIT, FOR PU20 & 04241 (KB)

4 INSTRUMENT TEST & CALIBRATION RECORD

For T108 test and calibration information, refer to Table 4-1.

For T108U test and calibration information, refer to Table 4-2.

For test and calibration information with CO₂, refer to Table 4-3.

Table 4-1. Final Test and Calibration Values for T108

TEST Parameters	Observed Value	Units	Acceptable Value
RANGE		PPB	50 - 20,000
STABIL		PPB	0.0 - 2
PRESS		" HG	24 - 35
SAMP FL		CC / MIN	500 - 700 w/CO ₂
PMT		mV	0 - 5000
UV LAMP		mV	3500 - 4000
STR. LGT		PPB	< 60
DRK PMT		MV	< 50
DRK LMP		MV	< 50
SLOPE			1.0 ± 0.3
OFFSET		MV	< 100
HVPS		V	400 - 900 constant
DCPS		MV	2500 +/- 200
RCELL TEMP		°C	50 +/- 1
BOX TEMP		°C	8-50
PMT TEMP		°C	7.9 +/- 1
IZS TEMP		°C	50 +/- .3
Electric Test			
PMT Volts		MV	1000 +/-200
TS Conc		PPB	500 +/- 100
Optic Test			
PMT Volts		MV	1000 +/- 200
TS Conc		PPB	500 +/- 100

Table 4-2. Test and Calibration Values for T108U

TEST PARAMETERS	OBSERVED VALUE	UNITS	ACCEPTABLE VALUE(S)
RANGE		PPB	5 - 20,000
STAB1		PPB	≤0.05 ppb with zero air
STAB2		PPB	≤0.1 ppb with zero air
PRESS		" HG	ambient ± 2
SAMPLE FL		CC / MIN	650 cm ³ /min ± 10%
PMT		mV	-20 TO 150 mV with zero air
UV LAMP		mV	2000 - 4800
STR LGT		PPB	< 25
DRK PMT		MV	200 - 325
DRK LMP		MV	-50 - 200
SLOPE			1.0 ± 0.3
OFFSET		MV	< 250
HVPS		V	≈ 400 to 900
RCELL TEMP		°C	50 ± 1°
BOX TEMP		°C	ambient + ~ 5
PMT TEMP		°C	7 ± 2
IZS TEMP (option)		°C	50 ± 1
Electric Test			
PMT Volts		MV	1000 +/-200
TS Conc		PPB	500 +/- 100
Optic Test			
PMT Volts		MV	1000 +/- 200
TS Conc		PPB	500 +/- 100

Table 4-3. Test and Calibrations Values w/ CO2 where applicable

Span and Cal		Values	Acceptable Value
Parameter	Observed Value	Units	Nominal Range
TS Span Conc.		PPB	20 - 20,000
TS Slope			1.0 +/- .3
TS Offset		MV	< 100
Noise at Zero (rms)		PPB	< 0.2
Noise at Span (rms)		PPB	< 0.5
PMT at Zero (SO ₂ /CO ₂)		MV	
PMT at Span (SO ₂ /CO ₂)		MV	
Measured Flows			
Parameter	Observed Value	Units	Nominal Range
Sample Flow w/ CO ₂		cc/min	500 - 700
Sample Flow w/Air		cc/min	400 - 600
Sample Press w/CO ₂		" HG	24 - 27
IZS Purge Flow		cc/min	50 +/- 10
H₂S Conversion Efficiency	Expected = _____	PPB	Actual = _____ PPB
			Efficiency = _____ % (100 ± 2%)
Factory Installed Options		Option Installed	
Power Voltage/Frequency			
Rack Mount, w/ Slides			
Rack Mount, w/ Ears Only			
Internal Zero/Span - IZS			
Permeation Tube (Output Specification)			
4-20 MA Current Loop Output			
External Pump			

PROM Rev #: _____

T108TS S/N: _____

M501TS S/N: _____

Date: _____

Technician: _____