



TELEDYNE
ADVANCED POLLUTION INSTRUMENTATION
A Teledyne Technologies Company

**ADDENDUM FOR TELEDYNE INSTRUMENTS'
M100E, M200E AND M300E FAMILY ANALYZERS**

O₂ SENSOR OPERATION

© TELEDYNE INSTRUMENTS
ADVANCED POLLUTION INSTRUMENTATION DIVISION
(TAPI)
9480 CARROLL PARK DRIVE
SAN DIEGO, CALIFORNIA 92121-5201
USA

Toll-free Phone: 800-324-5190
Phone: 858-657-9800
Fax: 858-657-9816
Email: api-sales@teledyne.com
Website: <http://www.teledyne-api.com/>

THIS PAGE IS INTENTIONALLY LEFT BLANK

TABLE OF CONTENTS

List of Figures	ii
List of Tables.....	ii
1. Introduction	1
1.1. Safety Messages.....	1
1.2. Overview	2
1.3. Reference Numbering convention	2
2. Specifications, Approvals and Warranty	3
2.1. Specifications	3
3. Getting Started	5
3.1. Physical Location of O ₂ Sensor.....	5
3.2. Physical LAYout of the O ₂ sensor.....	6
3.3. Pneumatic Location of O ₂ Sensor	7
3.4. Electrical Connections.....	10
3.4.1. Analog Output Connections	10
3.5. Pneumatic Connections	10
3.6. Initial Operation	10
4. Basic Operation of the O₂ sensor	11
4.1.1. O ₂ Concentration Display.....	11
4.1.2. Warning Message Display	11
4.1.3. Test Functions	11
4.2. Reporting Range SETUP	13
4.2.1. Setup with Standard Analog Outputs.....	13
4.2.2. Setup with User Configurable Analog Outputs	14
4.3. iDAS and the O ₂ Sensor	16
4.4. Using the E-Series AnalyZer with a Hessen Protocol Network	18
4.4.1. Gas List Entry Format and Definitions	18
4.4.2. Setting Hessen Protocol Status Flags	20
5. O₂ Calibration Procedures	23
5.1. O ₂ Calibration Setup	23
5.1.1. O ₂ Calibration Gasses	23
5.1.2. O ₂ Calibration Method.....	24
6. Theory of Operation.....	29
6.1. O ₂ Sensor Theory of Operation.....	29
6.1.1. Paramagnetic measurement of O ₂	29
6.1.2. Operation Within the E-Series Analyzer	29
6.2. Electronic Operation.....	30
6.2.1. Overview	30
6.2.2. Motherboard.....	30
6.2.3. Relay PCA	31
6.3. Power Supply/Circuit Breaker	32
6.3.1. AC Power Configuration	32
7. Maintenance Schedule & Procedures	35
8. Troubleshooting & Repair	37
DIAG → SIGNAL I/O: Using the Diagnostic Signal I/O Function.....	37
8.1. Using the Internal Electronic Status LEDs.....	39
8.1.1. Relay PCA Status LEDs	39
8.1.2. Setup Variables Related to the O ₂ sensor	40
8.2. Technical Assistance	41

LIST OF FIGURES

Figure 3-1:	Example of M200E Internal Layout with O ₂ Sensor Installed.....	5
Figure 3-2:	Layout & Dimensions of the O ₂ Sensor	6
Figure 3-3:	Base Configuration M100E Internal Pneumatics with O ₂ Sensor Installed	7
Figure 3-4:	Base Configuration M200E Internal Pneumatics with O ₂ Sensor Installed	7
Figure 3-5:	M200EM Internal Pneumatics with O ₂ Sensor Installed	8
Figure 3-6:	M200EH Internal Pneumatics with O ₂ Sensor Installed	8
Figure 3-7:	Base Configuration M300E Internal Pneumatics with O ₂ Sensor Installed	9
Figure 3-8:	Base Configuration M360E Internal Pneumatics with O ₂ Sensor Installed	9
Figure 4-1:	Example of O ₂ Sensor iDAS functions Imbedded into Default iDAS Channels	16
Figure 5-1:	Typical O ₂ Sensor Calibration Set Up.....	23
Figure 6-1:	Oxygen Sensor - Principle of Operation	29
Figure 6-2:	E-Series Analyzer Electronic Block Diagram with O ₂ Sensor.....	30
Figure 6-3:	Status LED Locations – Relay PCA for M100E and M200E Analyzers	31
Figure 6-4:	Status LED Locations – Relay PCA for M300E and M360E Analyzers	31
Figure 6-5:	Typical Jumper Set (JP2) Set Up of the O ₂ Sensor Heaters	32
Figure 6-6:	Location of AC Heater Connections and Jumpers for M100E and M200E Analyzers	33
Figure 8-1:	Accessing Signal I/O Functions	38

LIST OF TABLES

Table 2-1:	Specifications for the O ₂ Sensor	3
Table 3-1:	Typical Analog Output Assignment for E-Series Analyzers with O ₂ Sensors Installed	10
Table 4-1:	Additional O ₂ Sensor Warning Messages.....	11
Table 4-2:	Additional O ₂ Sensor Test Functions.....	11
Table 4-3:	Additional iDAS Triggering Events for E-Series Analyzers with O ₂ Sensors Installed	16
Table 4-4:	Additional iDAS Triggering Events for E-Series Analyzers with Optional O ₂ Sensors Installed..	16
Table 4-5:	Default Hessen Status Flag Assignments	20
Table 5-1:	NIST Standards for O ₂	23
Table 6-1:	Relay PCA Status LED's related to the O ₂ Sensor Heater	31
Table 6-2:	Power Configuration for Optional Heaters (JP6)	32
Table 8-1:	Typical E-Series Analyzer Signal I/O Definitions Applicable to the O ₂ Sensor	39
Table 8-2:	Relay PCA Status LED Failure Indications.....	39
Table 8-3:	Typical Setup Variables for E-Series Analyzers with the O ₂ Sensor Installed	40





USER NOTES:

1. INTRODUCTION

1.1. SAFETY MESSAGES

Your safety and the safety of others are very important. We have provided many important safety messages in this manual. Please read these messages carefully.

A safety message alerts you to potential hazards that could hurt you or others. Each safety message is associated with a safety alert symbol. These symbols are found in the manual and inside the M100E/M200E/M300E E-Series Family Analyzers. The definition of these symbols is described below:

	<p style="text-align: center;">CAUTION GENERAL SAFETY HAZARD</p> <p style="text-align: center;">Refers to the instructions for details on the specific hazard.</p>
	<p style="text-align: center;">CAUTION HOT SURFACE HAZARD.</p>
	<p style="text-align: center;">CAUTION ELECTRICAL SHOCK HAZARD.</p>
	<p style="text-align: center;">TECHNICIAN SYMBOL</p> <p style="text-align: center;">All operations marked with this symbol are to be performed by qualified maintenance personnel only.</p>

<p style="text-align: center;">NOTE</p> <p style="text-align: center;">Technical Assistance regarding the use and maintenance of the M200E or any other Teledyne Instruments product can be obtained by:</p> <p style="text-align: center;">Teledyne Instruments' Customer Service Department by telephone at 800-324-5190</p> <p style="text-align: center;">or</p> <p style="text-align: center;">via the internet at http://www.Teledyne-API.com</p>
--

1.2. OVERVIEW

This addendum is intended as a supplement to the operator's manuals for Teledyne Instruments' E-Series Analyzers. It provides an overview of the O₂ Sensor operation.

NOTE

Unless specifically mentioned in this addendum, the information contained in the of the Technical/Operator's Manual for your E-Series Analyzer applies equally to your analyzer when the optional O₂ Sensor is installed.

Only those topics where there is a difference between the operation of your analyzer and one with the optional O₂ Sensor installed are listed here.

1.3. REFERENCE NUMBERING CONVENTION

Unless otherwise specified, chapter, section, figure and table reference numbers referred to within this text are relative to this document.

EXAMPLE: "Figure 2-1" refers to the figure, within this document, labeled as 2-1.

References to chapters, sections, figures and tables in the original document will be labeled as such.

EXAMPLE: "Figure 6.1 of your E-series Technical/Operator's Manual".

USER NOTES:

2. SPECIFICATIONS, APPROVALS AND WARRANTY

2.1. SPECIFICATIONS

The specifications for the E-Series with the O₂ Sensor installed are similar to those listed in the Specifications Section of the Technical/Operator's Manual for your E-Series Analyzer with the following exceptions listed in Table 2-1.

Table 2-1: Specifications for the O₂ Sensor

Rise/Fall Time	≤ 60 sec to 95%
Sample Flow Rate	The O ₂ Sensor requires an additional 80 cm ³ /min
Range	0-100% O ₂
Accuracy	<± 0.1% O ₂
Linearity	<± 0.1% O ₂
Repeatability	<± 0.01% O ₂
Zero Drift	<±0.2% O ₂ per month (excludes up to <±0.1% O ₂ in the first 24 hours of operation)
Temp Co.	Zero: <± 0.03% O ₂ /°C, Span: <±0.05% of reading/°C
Ambient Humidity	0 to 95% RH.
Shock and Vibration	Meets requirements of BS EN 60068-2-6:1996 (IEC 68-2-6), BS EN 60068-2-27:1993 (IEC 68-2-27), IEC 68-2-34.
Safety Rating	EExia IIC. Component Certificate Ex99E2181U

USER NOTES:

USER NOTES:

3. GETTING STARTED

3.1. PHYSICAL LOCATION OF O₂ SENSOR

Generally the O₂ Sensor is located at the front-right of the E-Series Analyzer.

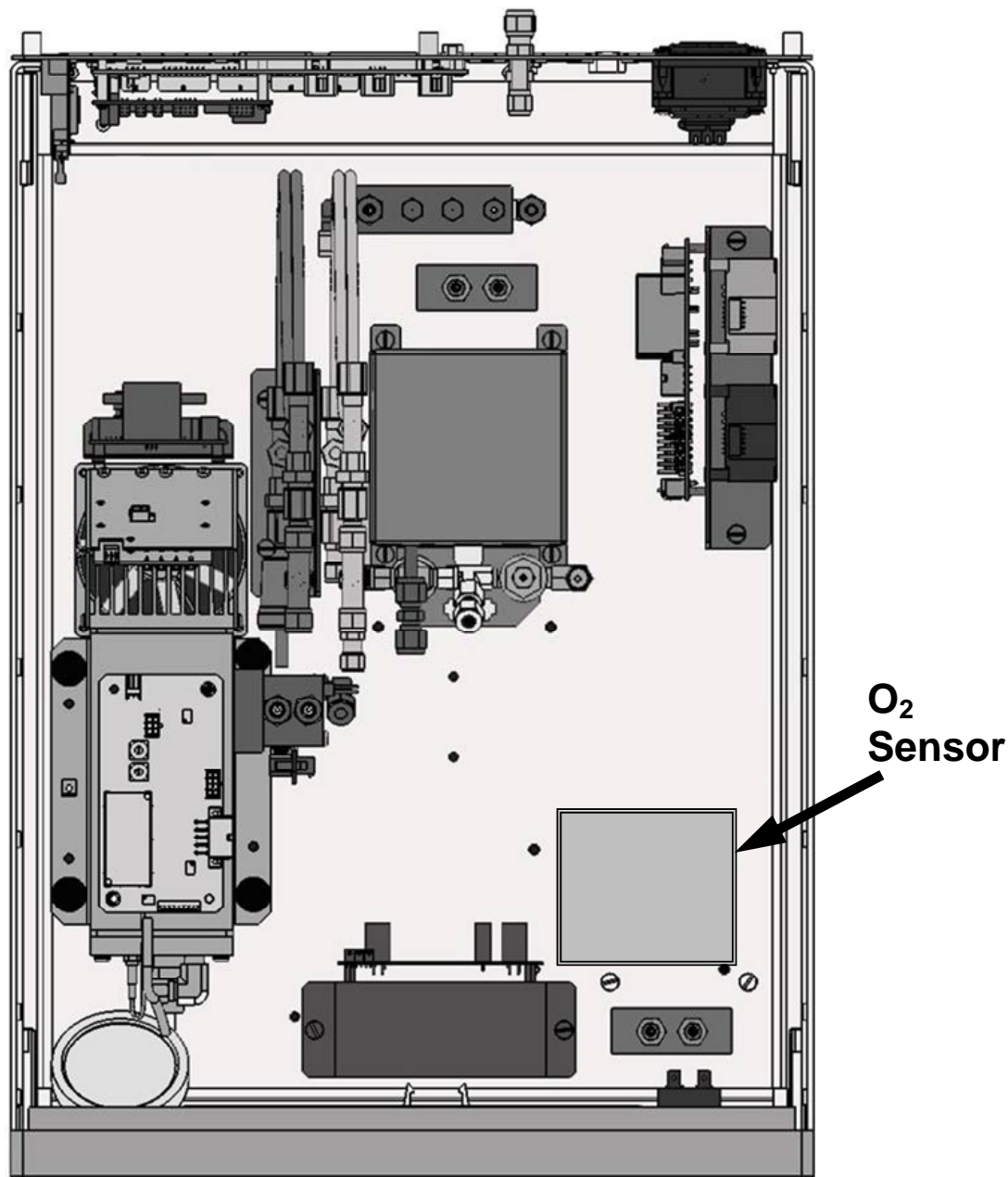

Figure 3-1: Example of M200E Internal Layout with O₂ Sensor Installed

3.2. PHYSICAL LAYOUT OF THE O₂ SENSOR

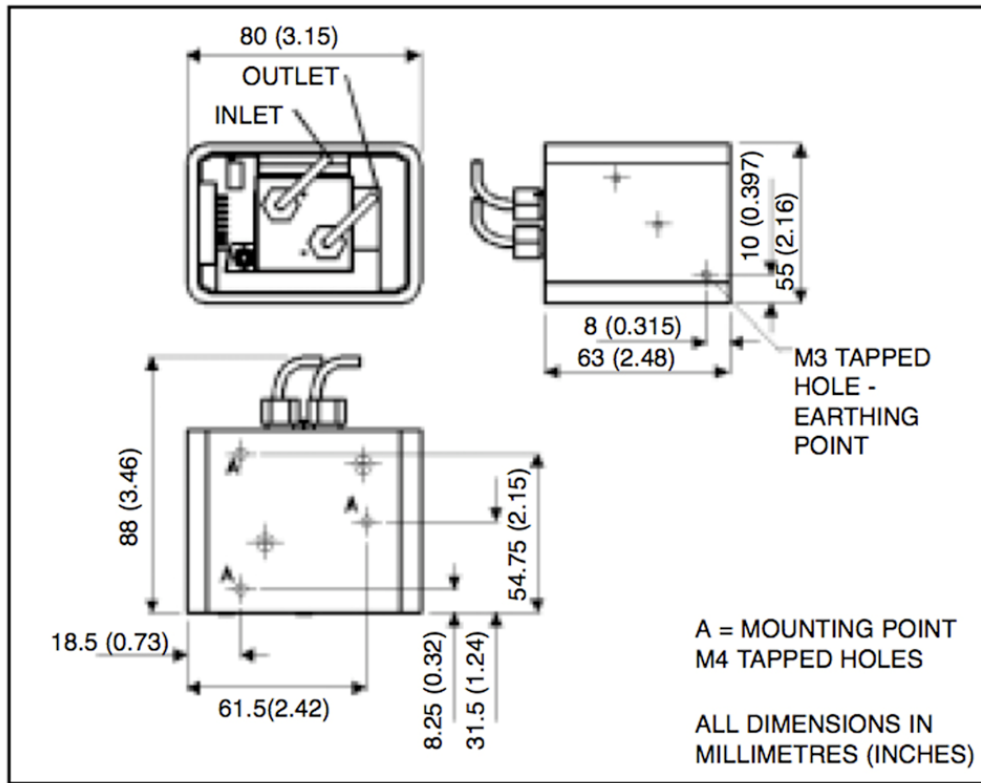

Figure 3-2: Layout & Dimensions of the O₂ Sensor

3.3. PNEUMATIC LOCATION OF O₂ SENSOR

Pneumatically the O₂ Sensor is generally inserted into the Sample Gas stream just downstream of the particulate filter.

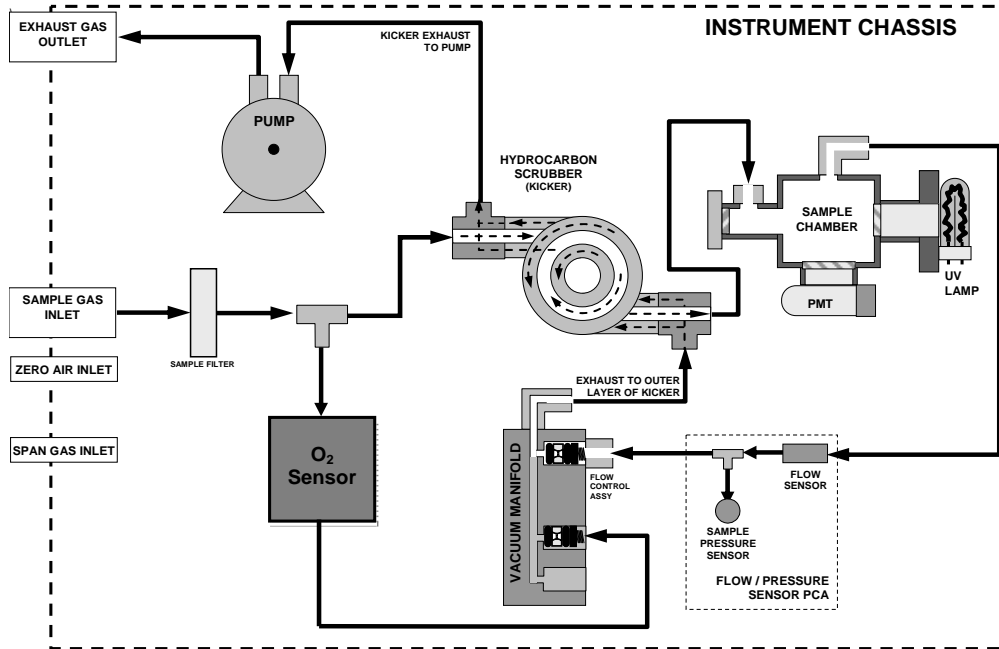

Figure 3-3: Base Configuration M100E Internal Pneumatics with O₂ Sensor Installed

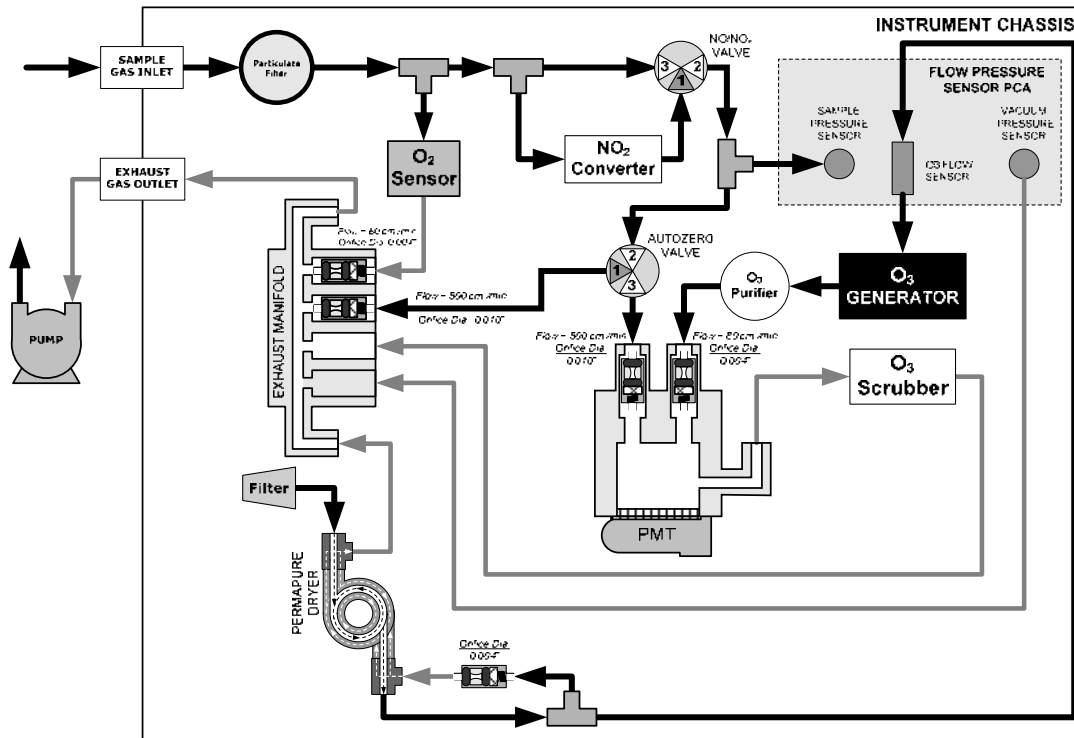

Figure 3-4: Base Configuration M200E Internal Pneumatics with O₂ Sensor Installed

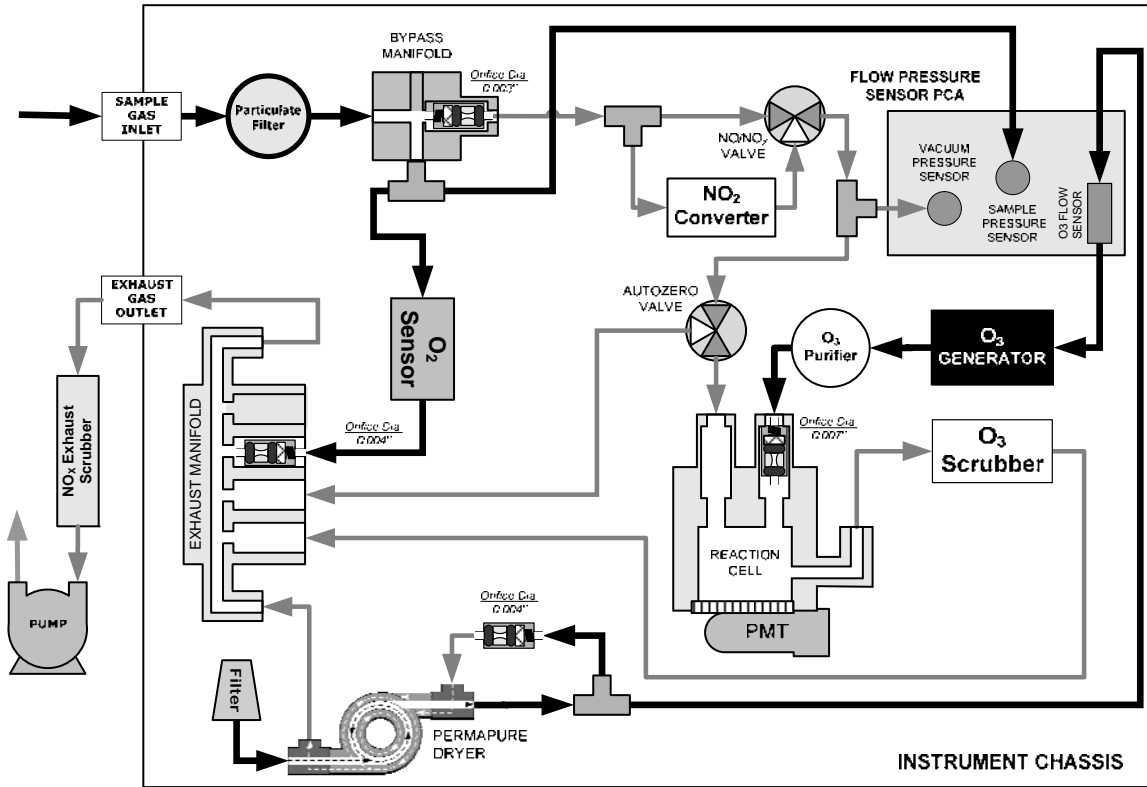

Figure 3-5: M200EM Internal Pneumatics with O₂ Sensor Installed

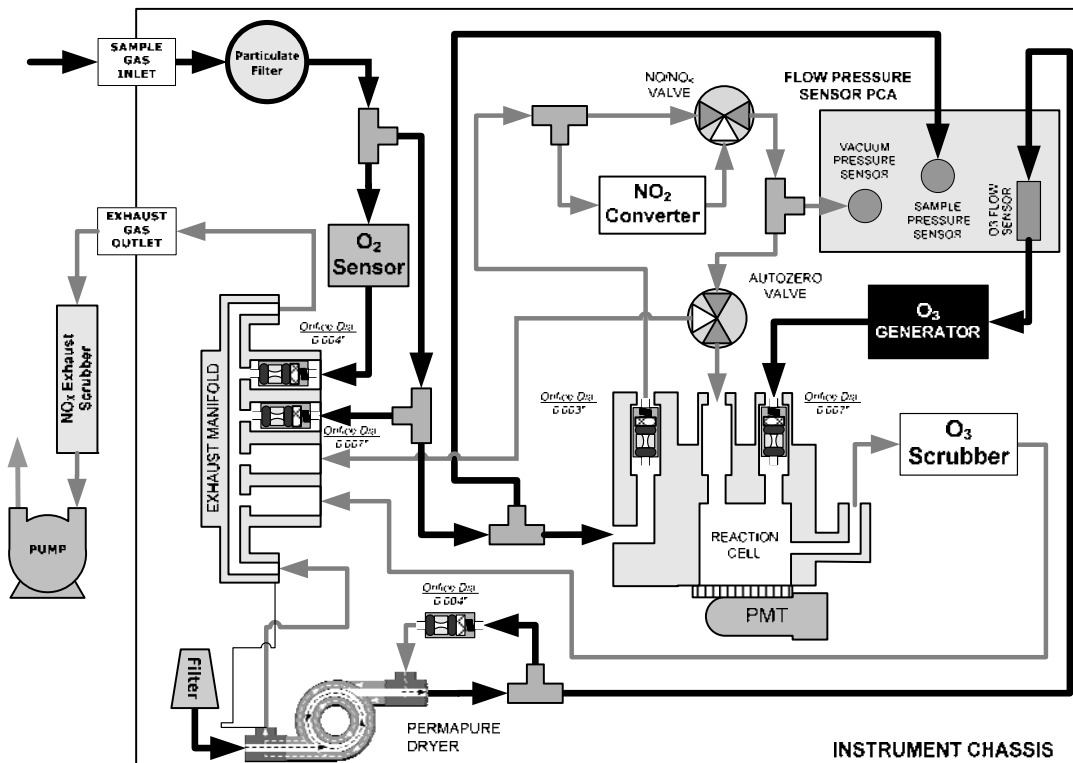

Figure 3-6: M200EH Internal Pneumatics with O₂ Sensor Installed

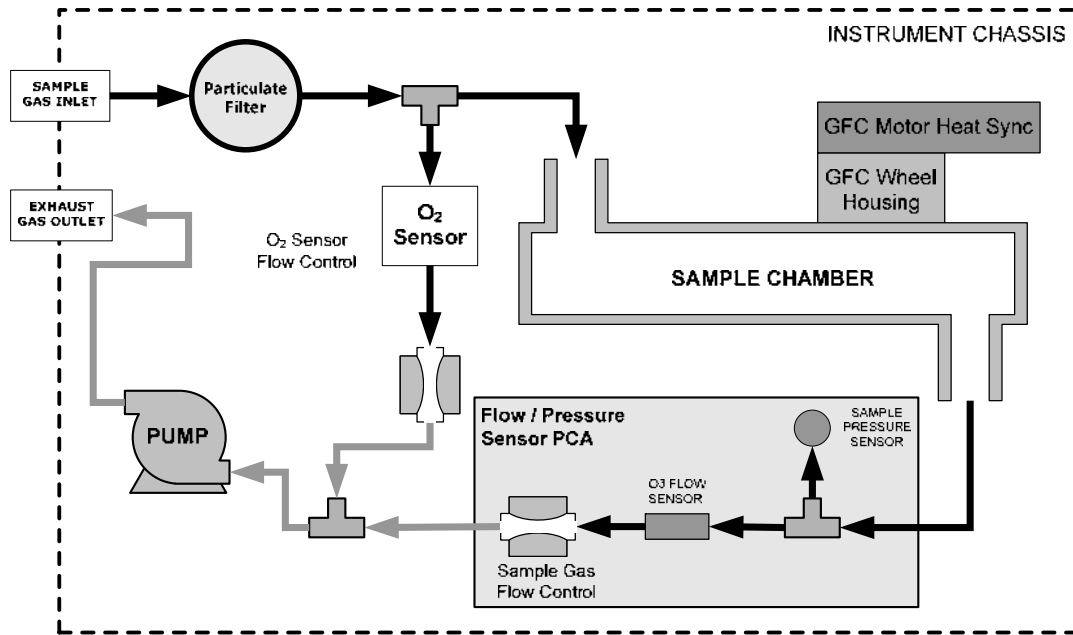

Figure 3-7: Base Configuration M300E Internal Pneumatics with O₂ Sensor Installed

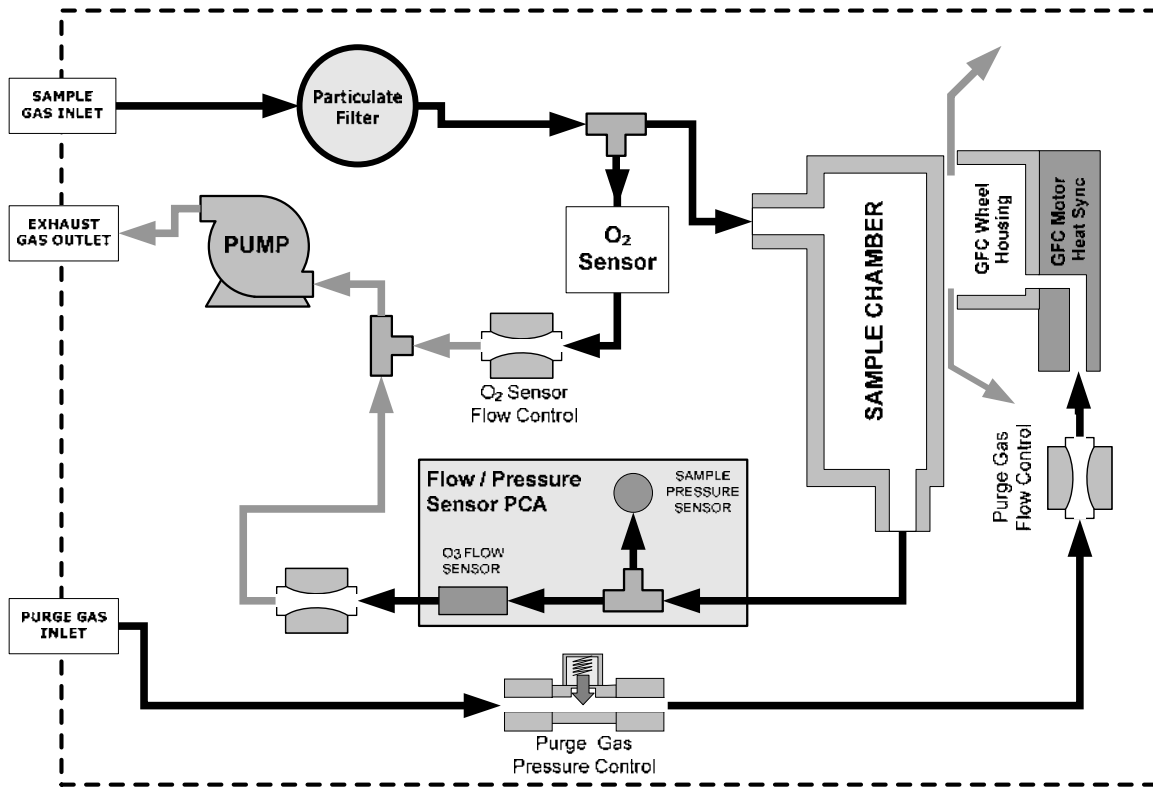

Figure 3-8: Base Configuration M360E Internal Pneumatics with O₂ Sensor Installed

3.4. ELECTRICAL CONNECTIONS

The electrical connections for your E-Series Analyzer with the O₂ Sensor installed are similar to those listed in the Technical/Operator's Manual for your E-Series Analyzer with the following exceptions:

3.4.1. ANALOG OUTPUT CONNECTIONS

One of the analog outputs of you E-Series Analyzer will be designated to reporting the O₂ concentration. The following table lists the most common configurations for each analyzer family however, refer to the Technical/Operator's Manual for your E-Series Analyzer for specific information about your model.

Table 3-1: Typical Analog Output Assignment for E-Series Analyzers with O₂ Sensors Installed

Model	Analog Output
M100E	A3
M200E	A4
M200EM/EH	A4
M300E	A3
M360E	A3

3.5. PNEUMATIC CONNECTIONS

There are no extra or special pneumatic connections required for E-Series Analyzers with the optional O₂ Sensor installed.

3.6. INITIAL OPERATION

Once the normal start up calibration of the analyzer's primary gas (NO_x, CO and SO_x) measurement system is completed, the O₂ Sensor should also be calibrated (See Chapter 5 of this addendum).

USER NOTES:

4. BASIC OPERATION OF THE O₂ SENSOR

4.1.1. O₂ CONCENTRATION DISPLAY

When the optional O₂ Sensor is installed in your E-Series Analyzer, the O₂ concentration will be displayed in the concentration field of the analyzers front panel. It will alternate with the other gas concentration(s) being measured by the instrument.

4.1.2. WARNING MESSAGE DISPLAY

Most E-Series Analyzer will also have an additional warning (see Table 4-1) when the optional O₂ Sensor is installed.

Table 4-1: Additional O₂ Sensor Warning Messages

MESSAGE	MEANING
O ₂ CELL TEMP WARN	O ₂ sensor cell temperature outside of warning limits specified by O ₂ _CELL_SET variable.

4.1.3. TEST FUNCTIONS

There will be several additional test functions (see Table 4-2) added to the list displayed on the front panel of your E-Series Analyzer when the optional O₂ sensor is installed.

Table 4-2: Additional O₂ Sensor Test Functions

DISPLAY	PARAMETER	UNITS	DESCRIPTION
O ₂ Range	Analog output range configuration	%	The temperature of gas inside the O ₂ sensor cell.
A[X]:O ₂ CNC1	Analog output range configuration	%	The temperature of gas inside the O ₂ sensor cell.
O ₂ CELL TEMP	O ₂ CELLTEMP	C	The temperature of gas inside the O ₂ sensor cell.
O ₂ SLOPE	O ₂ SLOPE	- -	The slope calculated during the most recent O ₂ zero/span calibration.
O ₂ OFFSET	O ₂ OFFSET	%	The offset calculated during the most recent O ₂ zero/span calibration.

4.1.3.1. Setting the Stability Test Function to show O₂

The stability test function (displayed as either (**STABIL**; [Gas Name]-**STB**)) is used during calibration operations to determine when the cal gas readings being made the analyzer have settled on their target values adequately. By default this test function is set to display the stability of the analyzer's primary gas-type.

To switch it to display O₂ measurement stability it is necessary to reset one of the instrument's **VARs**. Specifically the **STABIL_GAS VARs**.

To reset the value of this VARS, press:

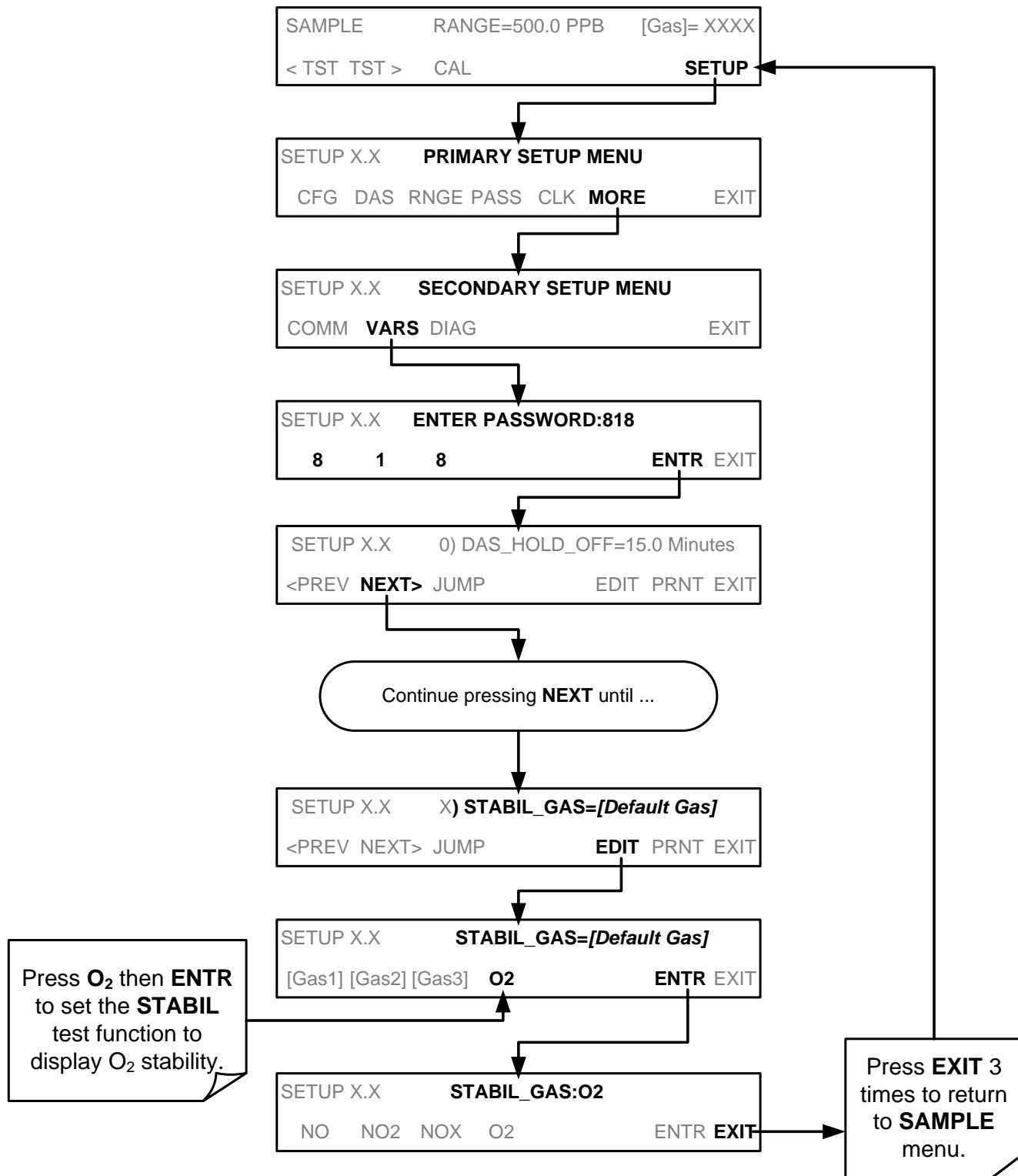

4.2. REPORTING RANGE SETUP

4.2.1. SETUP WITH STANDARD ANALOG OUTPUTS

If your E-Series Analyzer is configured with standard analog outputs the reporting range is defined by using the SET submenu under the RANGE menu as follows:

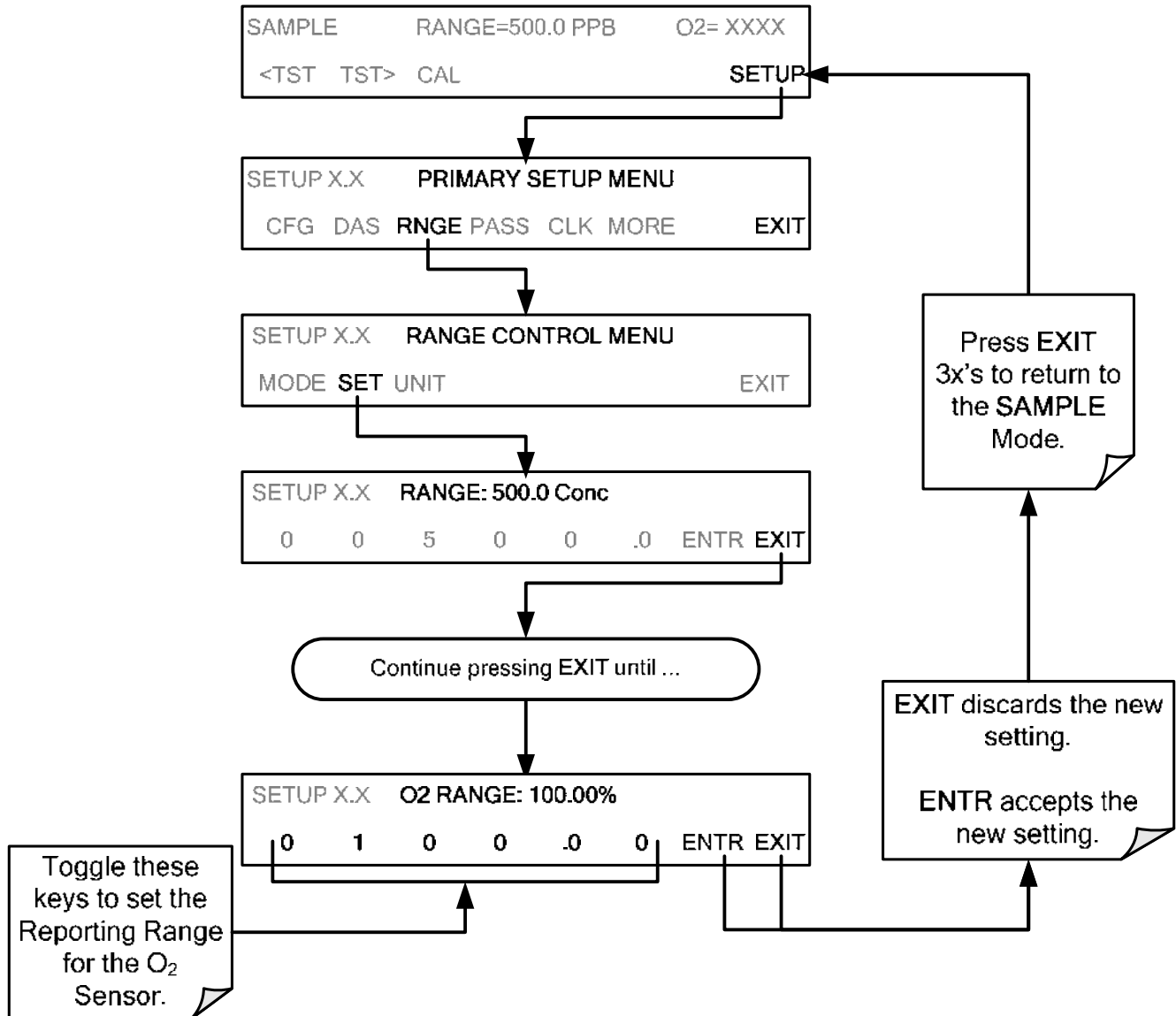

4.2.2. SETUP WITH USER CONFIGURABLE ANALOG OUTPUTS

If the E-Series Analyzer is configured with user configurable analog outputs, the O₂ reporting range setup is found under the AIO CONFIGURATION submenu by pressing:

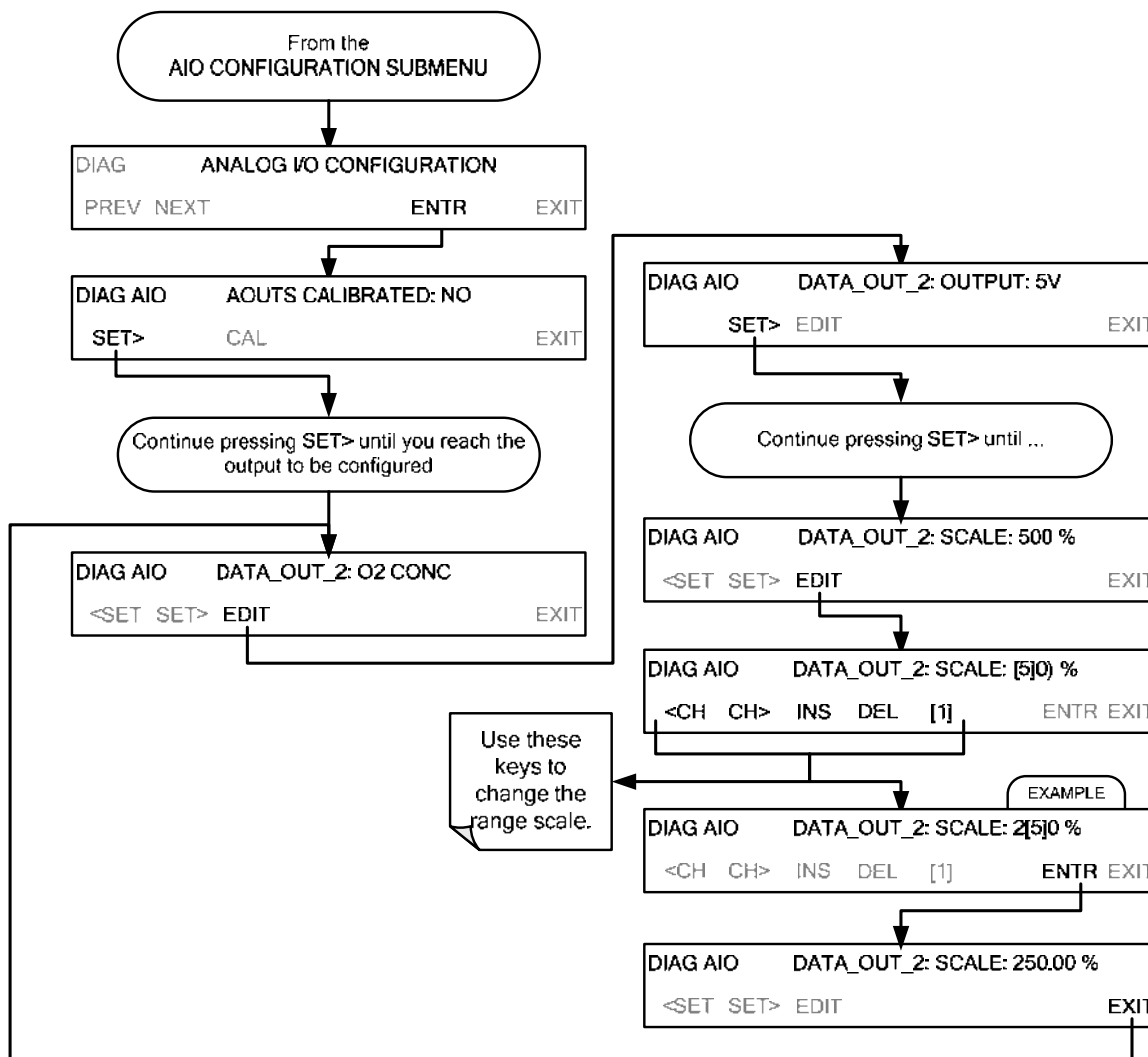

Range Selection Keypad Functions

KEY	FUNCTION
<CH	Moves the cursor one character to the left.
CH>	Moves the cursor one character to the right.
INS	Inserts a character before the cursor location.
DEL	Deletes a character at the cursor location.
[?]	Press this key to cycle through the range of numerals and characters available for insertion: 0-9; as well as "+" & "-".
ENTR	Accepts the new setting and returns to the previous menu.
EXIT	Ignores the new setting and returns to the previous menu.
Some keys only appear as needed.	

4.3. iDAS AND THE O₂ SENSOR

When the optional O₂ Sensor is installed in your E-Series Analyzer, there are several additional iDAS triggers and parameters.

Check the Technical/Operator's Manual for your E-Series Analyzer for specific information about your model.

Table 4-3: Additional iDAS Triggering Events for E-Series Analyzers with O₂ Sensors Installed

Name	Description
O2SLPC	O ₂ slope and offset recalculated
O2TMPW	O ₂ Sensor cell temperature warning

Table 4-4: Additional iDAS Triggering Events for E-Series Analyzers with Optional O₂ Sensors Installed

Name	Description	Units
O2SLPE	O ₂ slope	—
O2OFST	O ₂ offset	%
O2ZSCN	O ₂ concentration during zero/span calibration, just before computing new slope and offset	%
O2CONC	O ₂ concentration	%
O2TEMP	O ₂ sensor cell temperature	°C

Sometimes these additional iDAS functions are included in one of the E-Series Analyzer's default iDAS channels such as in the following example for the M200E Analyzer:

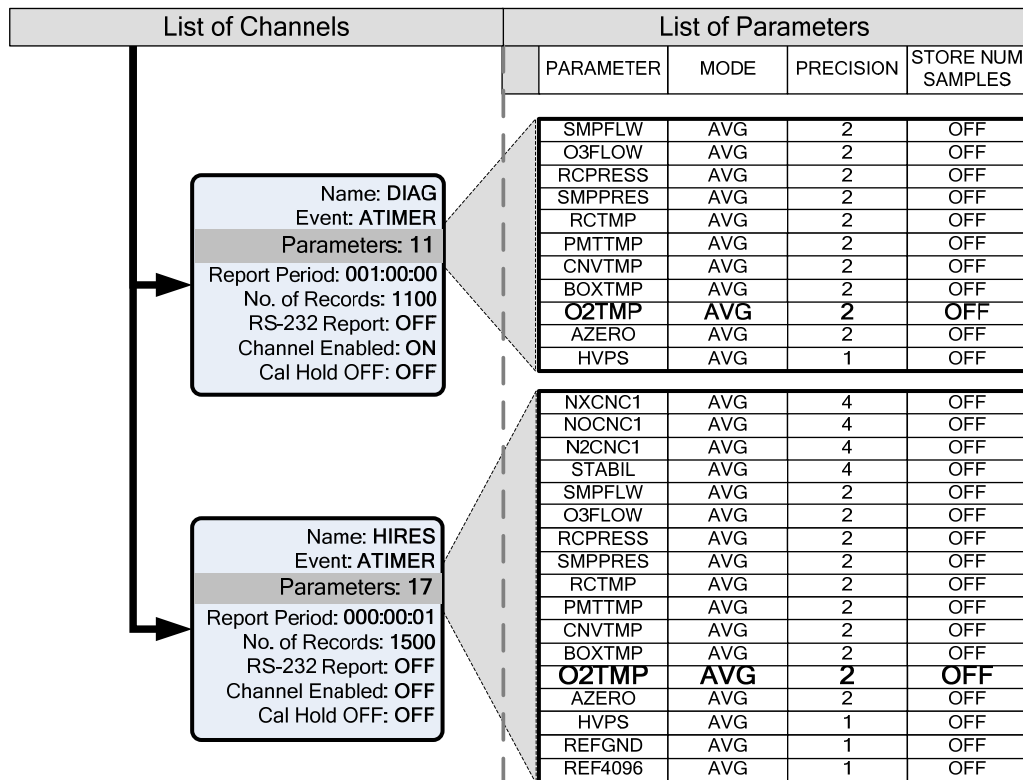

Figure 4-1: Example of O₂ Sensor iDAS functions Imbedded into Default iDAS Channels

4.4. USING THE E-SERIES ANALYZER WITH A HESSEN PROTOCOL NETWORK

4.4.1. GAS LIST ENTRY FORMAT AND DEFINITIONS

The default gas list for your E-Series Analyzer will include an additional listing that will look something like:

O2, 0, [Gas ID], REPORTED

The exact Gas ID will be different depending on the model of your E-Series Analyzer. Check the Technical/Operator's Manual for your E-Series Analyzer for specific information about your model.

To check or set the Gas ID for the O₂ Sensor of your E-Series Analyzer, press:

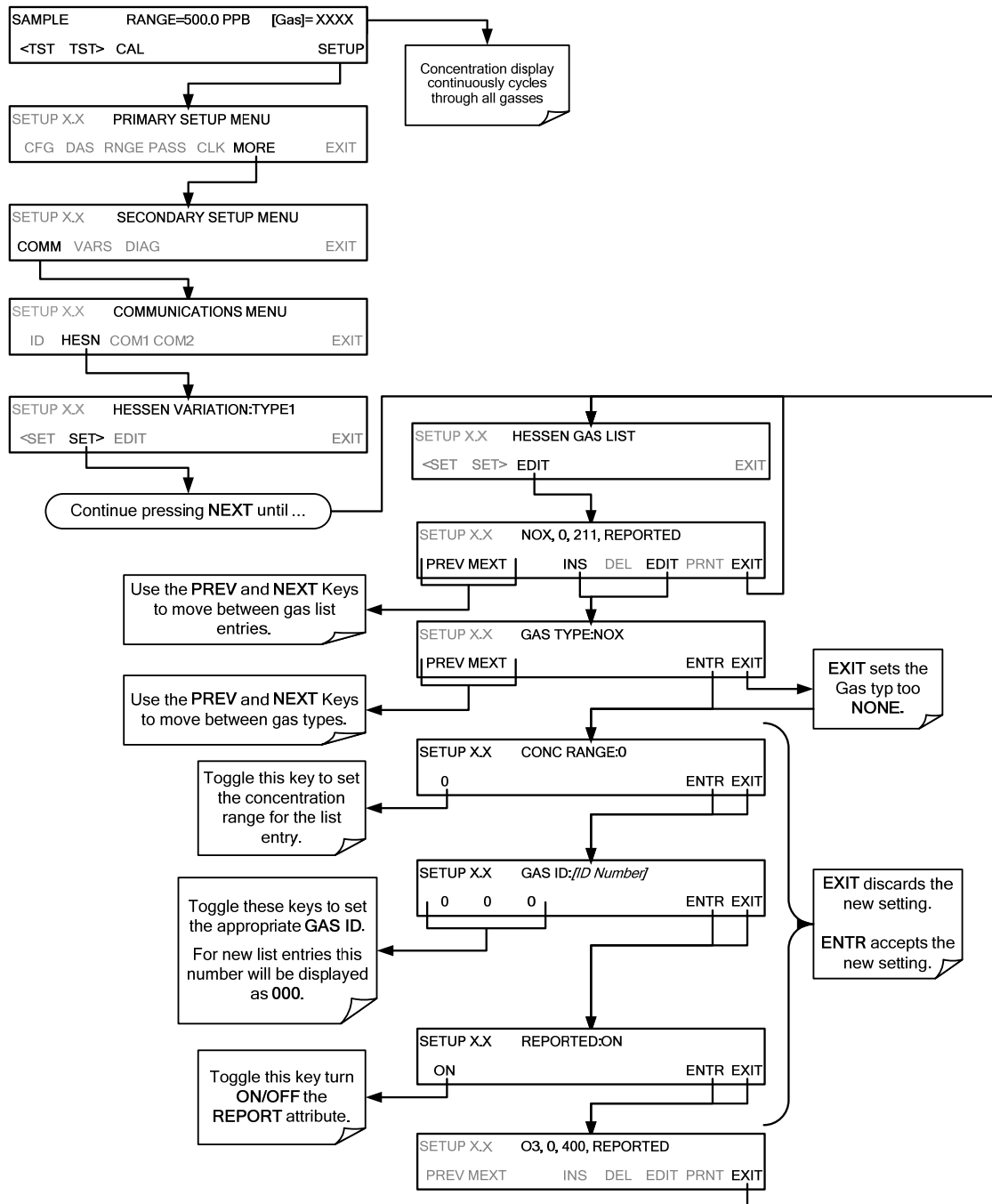

4.4.2. SETTING HESSEN PROTOCOL STATUS FLAGS

The Hessen Flag values for an E-Series Analyzer with the O₂ Sensor installed are similar to those listed in the Technical/Operator's Manual for your E-Series Analyzer with the additions. Check the manual for specific information about your model.

Table 4-5: Default Hessen Status Flag Assignments

STATUS FLAG NAME	DEFAULT BIT ASSIGNMENT
OPERATIONAL FLAGS	
In O ₂ SENSOR CALIBRATION Mode	0400
UNASSIGNED FLAGS (0000)	
O ₂ CELL TEMP WARN4	

To assign or reset the status flag bit assignments, press:

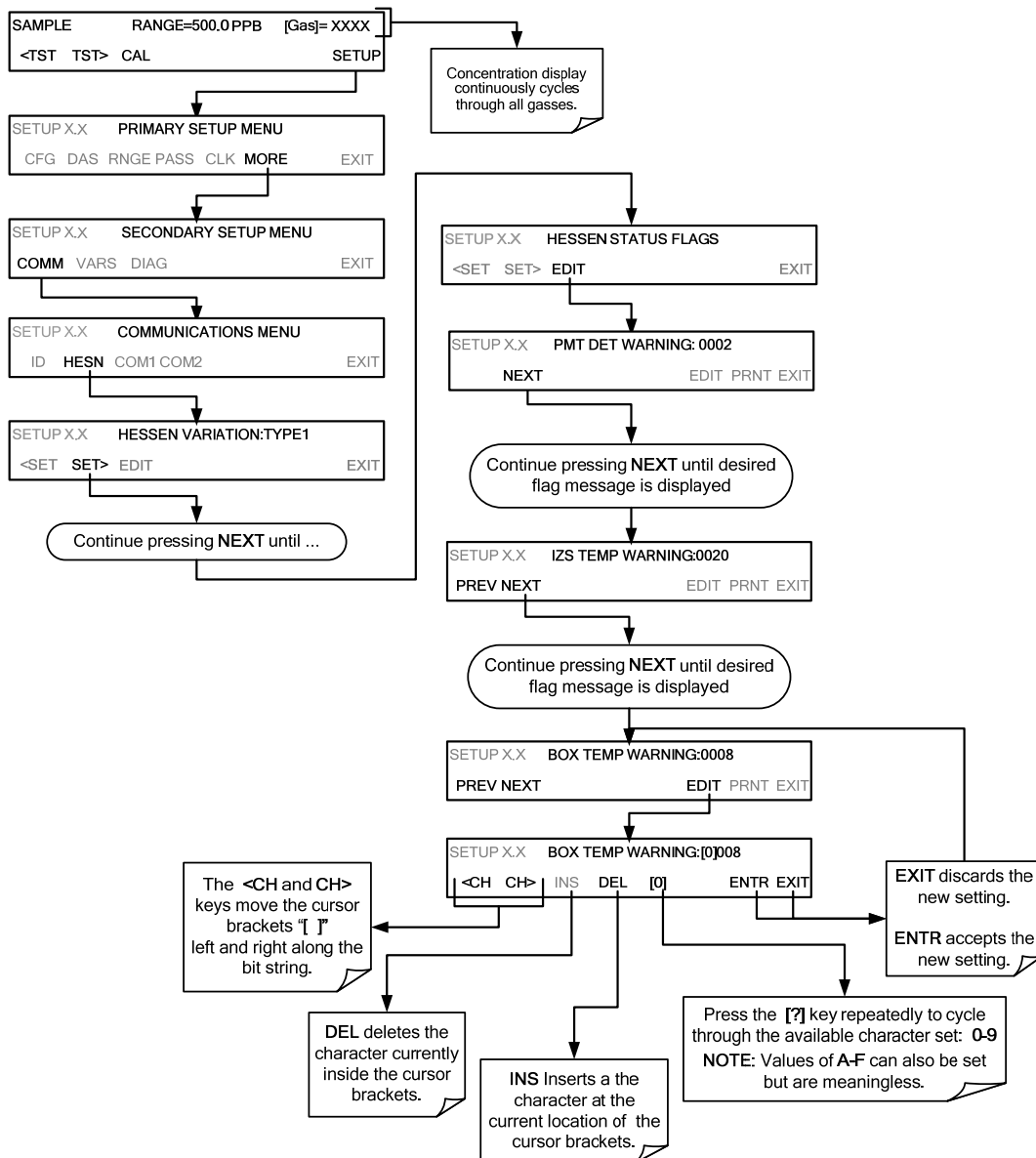

USER NOTES:

USER NOTES:

5. O₂ CALIBRATION PROCEDURES

5.1. O₂ CALIBRATION SETUP

The pneumatic connections for O₂ calibration are shown in Figure 5-1:

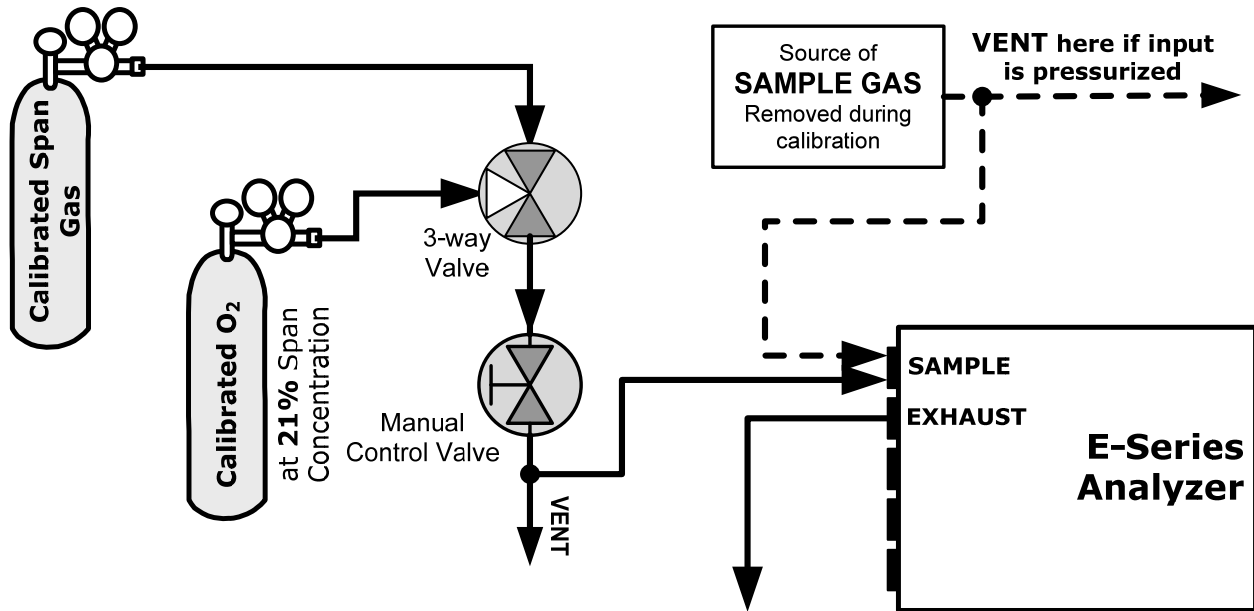

Figure 5-1: Typical O₂ Sensor Calibration Set Up

5.1.1. O₂ CALIBRATION GASSES

O₂ SENSOR ZERO GAS:

Teledyne Instruments recommends using pure N₂ when calibrating the zero point of your O₂ Sensor option.

O₂ SENSOR SPAN GAS:

Teledyne Instruments recommends using 21% O₂ in N₂ when calibrating the span point of your O₂ Sensor option. Cylinders of the following types of calibrated O₂ gas traceable to NIST-standards specifications (also referred to as EPA protocol calibration gases or Standard Reference Materials) are commercially available.

Table 5-1: NIST Standards for O₂

SRM	DESCRIPTION	NOMINAL AMOUNT OF SUBSTANCE
2657a	Oxygen in Nitrogen	2 %
2658a	Oxygen in Nitrogen	10 %
2659a	Oxygen in Nitrogen	21 %

5.1.2. O₂ CALIBRATION METHOD

STEP 1 – SET O₂ SPAN GAS CONCENTRATION:

This should be equal to the percent concentration of the O₂ span gas of the selected reporting range (default factory setting = 20.8%; the approximate O₂ content of ambient air).

```
SAMPLE      RANGE=500.0 PPB  [GAS]= XXXX
<TST TST >  CAL              SETUP
```

```
SAMPLE      GAS TO CAL:[default gas]
Gas1 Gas2 Gas3 O2          ENTR EXIT
```

```
SAMPLE      GAS TO CAL:O2
Gas1 Gas2 Gas3 O2          ENTR EXIT
```

```
M-P CAL    A1:NXCNC1 =100PPM  NOX=X.XXX
<TST TST>  ZERO SPAN CONC     EXIT
```

```
M-P CAL    O2 SPAN CONC:20.95%
| 0  2  0  .9  5 |          ENTR EXIT
```

EXIT ignores the new setting and returns to the previous display.
ENTR accepts the new setting and returns to the previous menu.

The O₂ span concentration value automatically defaults to **20.8%**.
If this is not the the concentration of the span gas being used, toggle these buttons to set the correct concentration of the O₂ calibration gases.

STEP 2 – ACTIVATE O₂ SENSOR STABILITY FUNCTION:

For instructions on changing the stability test function from to reflect readings made by the O₂ Sensor output, see Section 4.1.3.1.

NOTE

Reset the STB test function to NO_x when the O₂ calibration procedure is complete.

STEP 3 – O₂ ZERO/SPAN CALIBRATION:

To perform the zero/span calibration procedure, press:

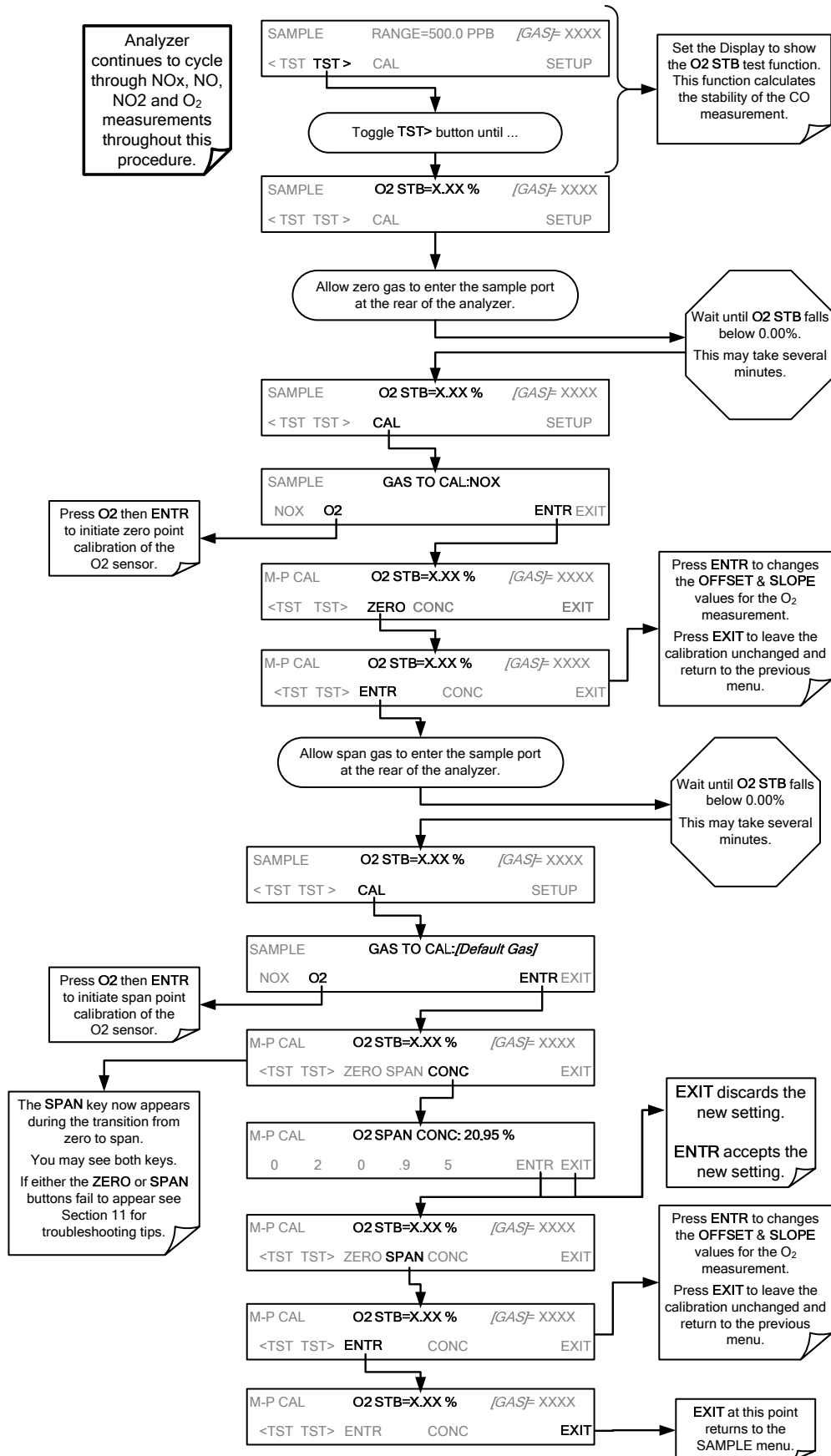

USER NOTES:

USER NOTES:

6. THEORY OF OPERATION

6.1. O₂ SENSOR THEORY OF OPERATION

6.1.1. PARAMAGNETIC MEASUREMENT OF O₂

The O₂ Sensor used in the E-Series Analyzer utilizes the fact that oxygen is attracted into strong magnetic field; most other gases are not, to obtain fast, accurate oxygen measurements.

The sensor's core is made up of two nitrogen filled glass spheres, which are mounted on a rotating suspension within a magnetic field. A mirror is mounted centrally on the suspension where light is emitted onto the mirror and reflects the light onto a pair of photocells. The signal generated by the photocells is passed to a feedback loop, which outputs a current to a wire winding (in effect, a small DC electric motor) mounted on the suspended mirror.

Oxygen from the sample stream is attracted into the magnetic field displacing the nitrogen filled spheres and causing the suspended mirror to rotate. This changes the amount of light reflected onto the photocells and therefore the output levels of the photocells. The feedback loop increases the amount of current fed into the winding in order to move the mirror back into its original position. The more O₂ present, the more the mirror moves and the more current is fed into the winding by the feedback control loop.

A sensor measures the amount of current generated by the feedback control loop, which is directly proportional to the concentration of oxygen within the sample gas mixture.

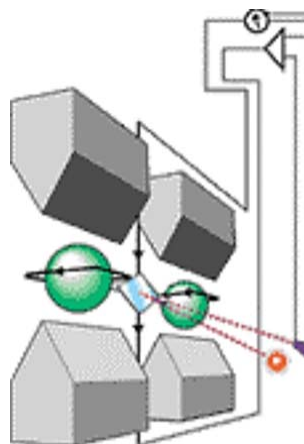

Figure 6-1: Oxygen Sensor - Principle of Operation

6.1.2. OPERATION WITHIN THE E-SERIES ANALYZER

The oxygen sensor option is transparently integrated into the core analyzer operation. All functions can be viewed or accessed through the front panel, just like the functions for NO_x.

- The O₂ concentration is displayed in the upper right-hand corner, alternating with the instrument's other gas concentrations.
- Test functions for O₂ slope and offset are viewable from the front panel along with the analyzer's other test functions.
- O₂ Sensor calibration is performed via the front panel **CAL** function and is performed in a nearly identical manner as the standard NO_x/NO calibration.
- Stability of the O₂ Sensor can be viewed by performing a zero/span calibration as shown in Section 5.1.2, Step 3.

The O₂ concentration range is 0-100% (user selectable) with 0.1% precision and accuracy and is available to be output via the instrument's fourth output **A4**.

The O₂ Sensor is maintained at a constant temperature of 50°C by means of a Proportional Integral Derivative (PID) loop and can be viewed on the front panel as test function **O2 CELL TEMP**.

The O₂ Sensor assembly itself does not have any serviceable parts and is enclosed in an insulated canister.

6.2. ELECTRONIC OPERATION

6.2.1. OVERVIEW

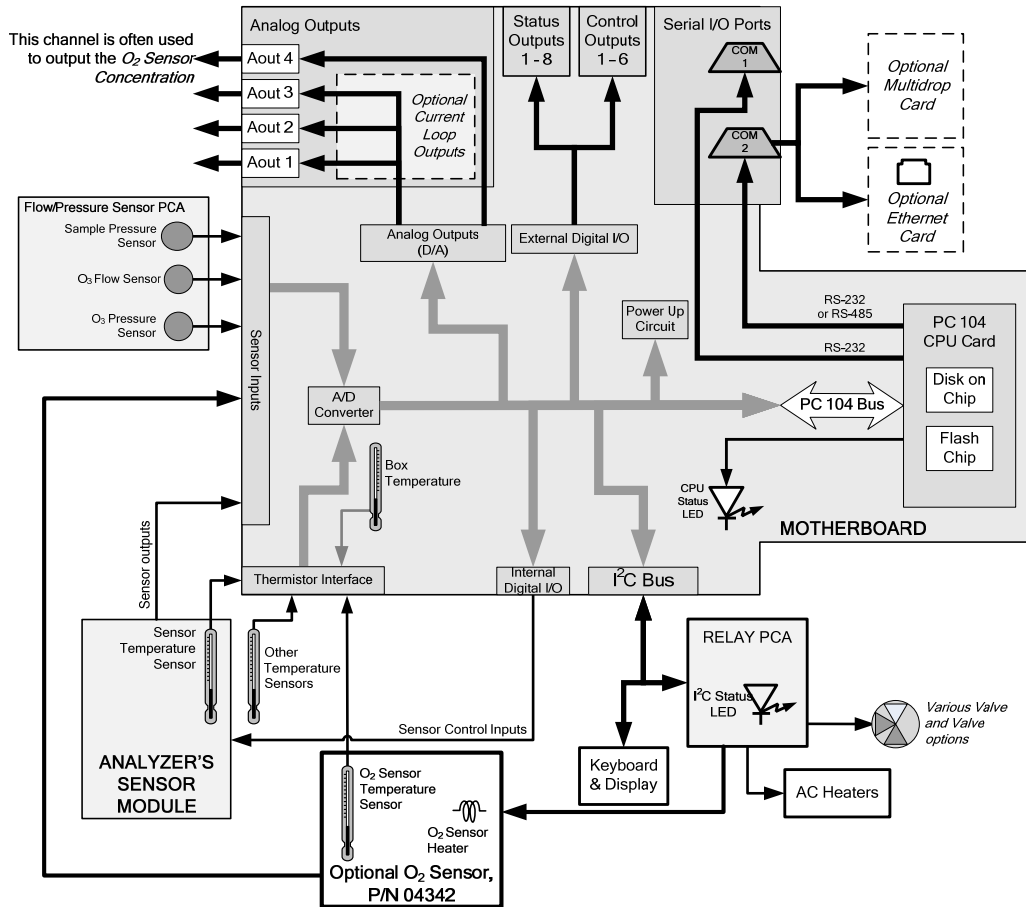

Figure 6-2: E-Series Analyzer Electronic Block Diagram with O₂ Sensor

6.2.2. MOTHERBOARD

This Printed Circuit Assembly (PCA) provides a multitude of functions including, A/D conversion, digital input/output, PC-104 to I²C translation, temperature sensor signal processing and is a pass through for the RS-232 and RS-485 signals. When the optional O₂ Sensor is installed the following additional input is included.

6.2.2.1. Thermistor Interface

O₂ HEATER SENSOR: The O₂ Sensor temperature sensor is a thermistor embedded in the O₂ Sensor housing. This temperature is used to maintain the efficiency of the O₂ Sensor operation.

Signals related to this sensor are generally available as follows, but refer to the Technical/Operator's Manual for your E-Series Analyzer for specific information about your model.

- The value of this signal is viewable via the front panel test function **O2 CELL TEMP** and the SIGNAL I/O function **O2_CELL_TEMP**.
- This measurement is stored in the analyzer's iDAS and reported as test function **RCEL TEMP**.
- It is recorded by the iDAS system as the parameter **O2TEMP**.

6.2.3. RELAY PCA

6.2.3.1. Status LED's

The Relay PCA for your E-Series Analyzer includes a status LED related to the heater on the O₂ Sensor. When this LED is lit, the heater is on. When it is unlit, the heater is off.

Table 6-1: Relay PCA Status LED's related to the O₂ Sensor Heater

Analyzer Family	LED	Color
M100E Family	D5	Yellow
M200E Family	D6	Yellow
M300E	D4	Yellow

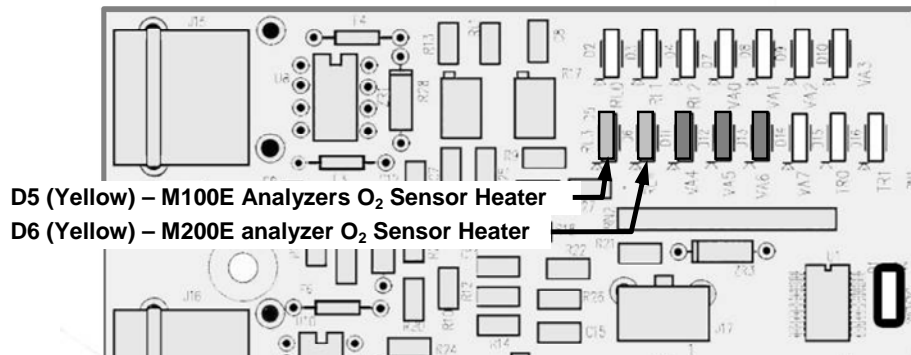

Figure 6-3: Status LED Locations – Relay PCA for M100E and M200E Analyzers

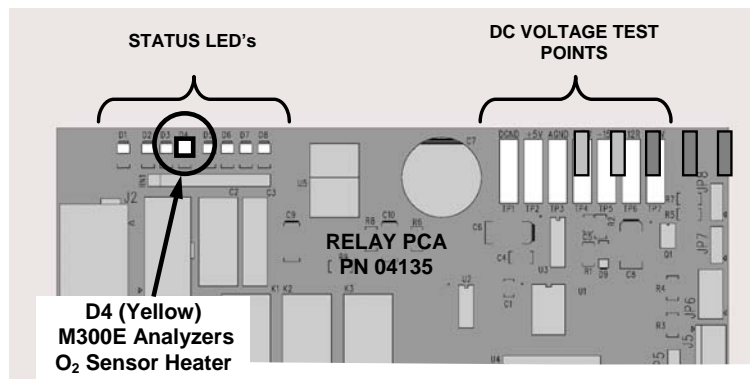

Figure 6-4: Status LED Locations – Relay PCA for M300E and M360E Analyzers

6.3. POWER SUPPLY/CIRCUIT BREAKER

6.3.1. AC POWER CONFIGURATION

The following information is applicable for M100E and M200E Family Analyzers, except as noted.

The M300E and M360E Analyzers use a different Relay PCA. Refer to the Technical/Operator's Manual for your E-Series Analyzer for specific information about your model regarding the O₂ Sensor interface with the Relay PCA.

The O₂ Sensor is currently not available on the M400E Family Analyzers.

6.3.1.1. AC Configuration – Heaters for Option Packages (JP6)

The O₂ Sensor options include an AC heater that maintains it at an optimum operating temperature. Jumper set JP6 is used to connect the heaters associated with this sensor to AC power.

Since these heaters work with either 110/155 VAC or 220/240 VAC, there is only one jumper configuration.

Table 6-2: Power Configuration for Optional Heaters (JP6)

JUMPER COLOR	HEATER(S)	JUMPER BETWEEN PINS	FUNCTION
RED		2 to 7	Neutral to Load
	O ₂ Sensor Heater	3 to 10	Common
		4 to 9	Neutral to Load

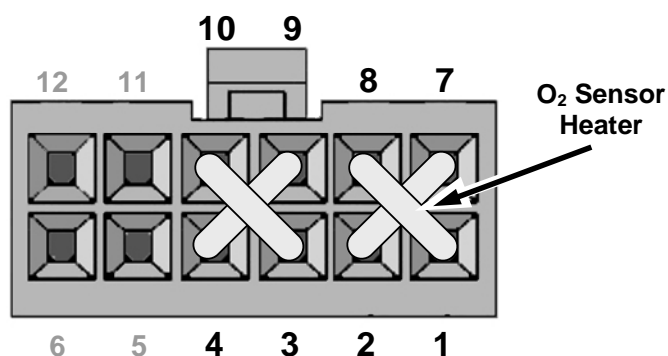

Figure 6-5: Typical Jumper Set (JP2) Set Up of the O₂ Sensor Heaters

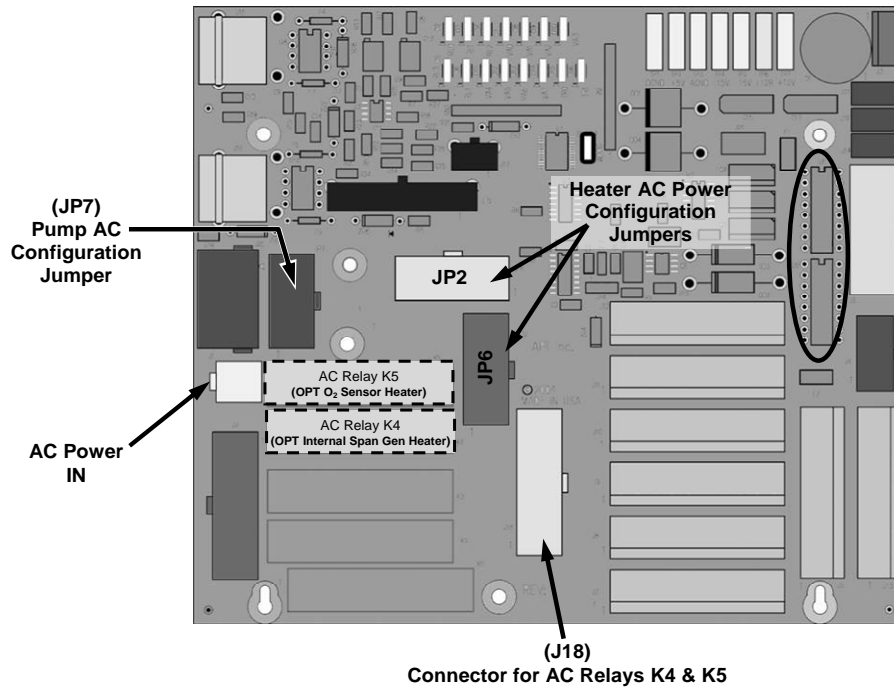

Figure 6-6: Location of AC Heater Connections and Jumpers for M100E and M200E Analyzers

USER NOTES:

USER NOTES:

7. MAINTENANCE SCHEDULE & PROCEDURES

There are no special maintenance procedures for the O₂ Sensor.

USER NOTES:

USER NOTES:

8. TROUBLESHOOTING & REPAIR

With the following exception, there are no special troubleshooting procedures related to the O₂ Sensor beyond those describes in the Troubleshooting and Repair Chapter of the Technical/Operator's Manual for your E-Series Analyzer for specific information about your model.

NOTE

Ensure that liquid water from the sampling system does not go through the O₂ Sensor. If liquid water is present in the O₂ Sensor, the O₂ Sensor cannot be recovered and must be replaced.

DIAG → SIGNAL I/O: USING THE DIAGNOSTIC SIGNAL I/O FUNCTION

The signal I/O diagnostic mode allows access to the digital and analog I/O in the analyzer. Some of the digital signals can be controlled through the keyboard. These signals, combined with a thorough understanding of the instrument's Theory of Operation are useful for troubleshooting in three ways:

- The technician can view the raw, unprocessed signal level of the analyzer's critical inputs and outputs.
- Many of the components and functions that are normally under algorithmic control of the Central Processing Unit (CPU) can be manually exercised.
- The technician can directly control the signal level Analog and Digital Output signals.

This allows the technician to observe systematically the effect of directly controlling these signals on the operation of the analyzer.

Figure 8-1 is an example of how to use the Signal I/O Menu to view the raw voltage of an input signal or to control the state of an output voltage or control signal.

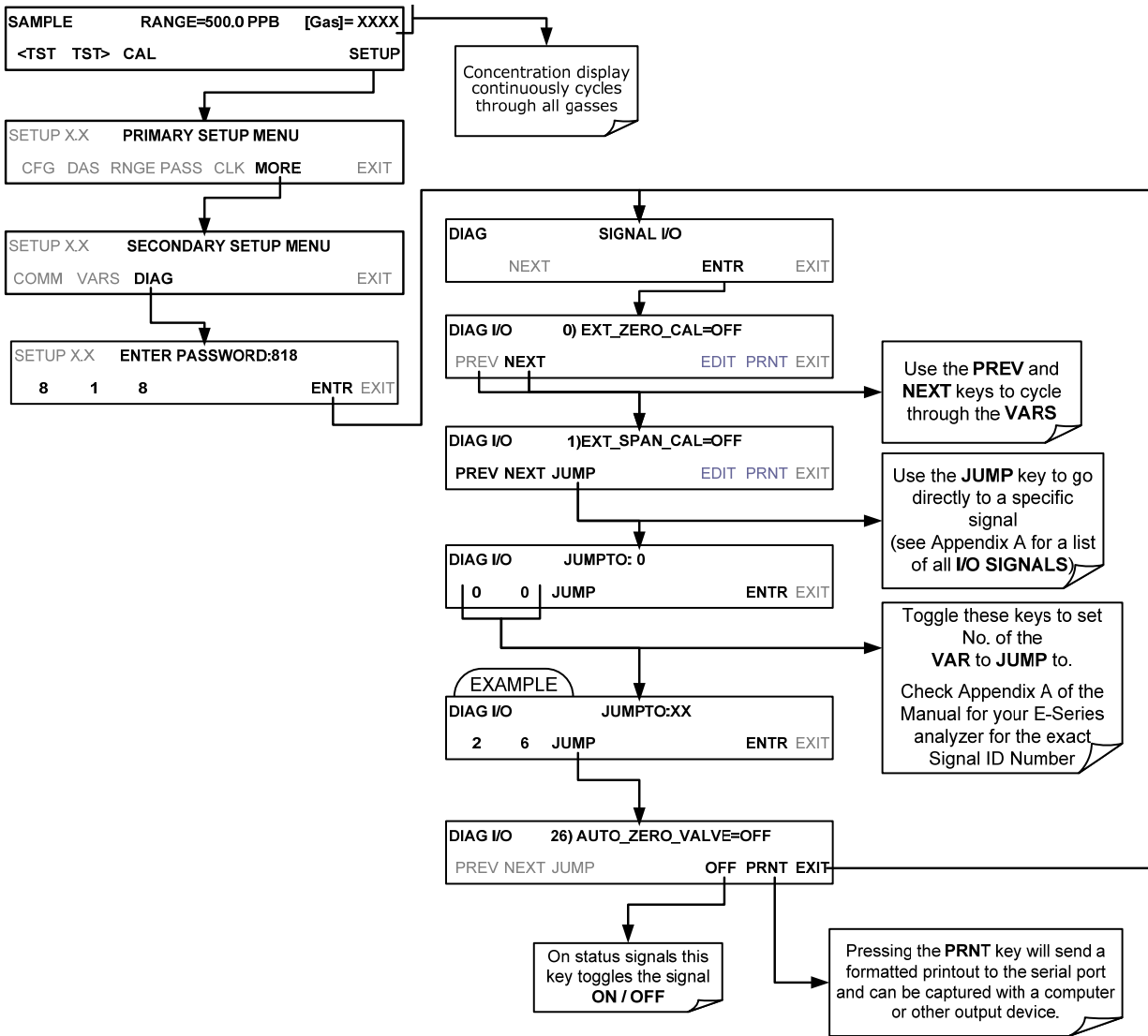

Figure 8-1: Accessing Signal I/O Functions

NOTE

Any I/O signals changed while in the Signal I/O Menu will remain in effect **ONLY** until Signal I/O Menu is exited. The analyzer regains control of these signals upon exit.
 See Appendix A-4 (of the Technical/Operator's Manual for your E-Series Analyzer) for a complete list of the parameters available for review under this menu.

Table 8-1: Typical E-Series Analyzer Signal I/O Definitions Applicable to the O₂ Sensor

Signal Name	Bit or Channel Number	Description
A status outputs, U24, J1017, pins 1–8 = bits 0–7, default I/O address 323 hex		
ST_O2_CAL	7	0 = in O ₂ calibration mode 1 = in measure or other calibration mode
Relay board digital output (PCF8575), default I²C address 44 hex		
O2_CELL_HEATER	5	0 = O ₂ Sensor cell heater on 1 = off
Rear board primary MUX analog inputs, MUX default I/O address 32A hex		
O2_SENSOR	6	O ₂ concentration sensor
Rear board temperature MUX analog inputs, MUX default I/O address 326 hex		
O2_CELL_TEMP	4	O ₂ Sensor cell temperature

The above signals may differ for your E-Series Analyzer. Check the Technical/Operator's Manual for your E-Series Analyzer for specific information about your model.

8.1. USING THE INTERNAL ELECTRONIC STATUS LEDES

8.1.1. RELAY PCA STATUS LEDES

Table 8-2: Relay PCA Status LED Failure Indications

LED	COLOR	FUNCTION	FAULT STATUS	INDICATED FAILURE(S)
D4 (M300E) D5 (M100E) D6 (M200E)	Yellow	O ₂ Sensor Heater	Continuously ON or OFF	Heater broken, thermocouple broken.

8.1.2. SETUP VARIABLES RELATED TO THE O₂ SENSOR

When the optional O₂ sensor is installed in your E-Series Analyzer, the additional set up variables (VARS) will apply. There may be differences between the actual setup VARS for your E-Series Analyzer and those shown in Table 8-3. Check the Technical/Operator's Manual for your E-Series Analyzer for specific information about your model.

Table 8-3: Typical Setup Variables for E-Series Analyzers with the O₂ Sensor Installed

Setup Variable	Numeric Units	Default Value	Value Range	Description
LOW ACCESS LEVEL SETUP VARIABLES (818 PASSWORD)				
STABIL_GAS	—	NOX	NO, NO ₂ , NOX, O ₂	Selects gas for stability measurement. Enclose value in double quotes (") when setting from the RS-232 interface.
O ₂ _DWELL	Seconds	1	0.1–30	Dwell time before taking each sample.
O ₂ _FILT_ADAPT	—	ON	ON, OFF	ON enables O ₂ adaptive filter; OFF disables it.
O ₂ _FILT_SIZE	Samples	60	1–500	O ₂ moving average filter size in normal mode.
O ₂ _FILT_ASIZE	Samples	10	1–500	O ₂ moving average filter size in adaptive mode.
O ₂ _FILT_DELTA	%	2	0.1–100	Absolute change in O ₂ concentration to shorten filter.
O ₂ _FILT_PCT	%	2	0.1–100	Relative change in O ₂ concentration to shorten filter.
O ₂ _FILT_DELAY	Seconds	20	0–300	Delay before leaving O ₂ adaptive filter mode.
O ₂ _DIL_FACTOR	—	1	0.1–1000	Dilution factor for O ₂ . Used only if is dilution enabled with <i>FACTORY_OPT</i> variable.
O ₂ _SLOPE	—	1	0.5–2	O ₂ slope.
O ₂ _OFFSET	%	0	-10–10	O ₂ offset.
O ₂ _RANGE	%	100	0.1–500	O ₂ concentration range.
O ₂ _CELL_SET	°C	50 Warnings: 45–55	30–70	O ₂ sensor cell temperature set point and warning limits.
O ₂ _CELL_CYCLE	Seconds	10	0.5–30	O ₂ cell temperature control cycle period.
O ₂ _CELL_PROP	—	1	0–10	O ₂ cell PID temperature control proportional coefficient.
O ₂ _CELL_INTEG	—	0.1	0–10	O ₂ cell PID temperature control integral coefficient.
O ₂ _CELL_DERIV	—	0 (disabled)	0–10	O ₂ cell PID temperature control derivative coefficient.

8.2. TECHNICAL ASSISTANCE

If this manual and its Troubleshooting & Repair sections do not solve your problems, technical assistance may be obtained from:

**Teledyne Instruments, Customer Service,
9480 Carroll Park Drive
San Diego, California 92121-5201USA**

Toll-free Phone: 800-324-5190

Phone: 858-657-9800

Fax: 858-657-9816

Email: api-sales@teledyne.com

Website: <http://www.Teledyne-API.com>

Before you contact Teledyne Instruments' Customer service, fill out the problem report form in Appendix C, which is also available online for electronic submission at <http://www.Teledyne-API.com/forms>.

USER NOTES:

USER NOTES: