



**TELEDYNE**  
ADVANCED POLLUTION INSTRUMENTATION  
A Teledyne Technologies Company

## MANUAL ADDENDUM

# ***MODEL M100EH*** ***UV FLUORESCENCE SO<sub>2</sub> ANALYZER***

(Standalone Addendum – For use with the M100E Instruction Manual, P/N 04515)

© TELEDYNE ADVANCED POLLUTION INSTRUMENTATION  
(T-API)  
9480 CARROLL PARK DRIVE  
SAN DIEGO, CA 92121-5201  
USA





Toll-free Phone: 800-324-5190  
Phone: 858-657-9800  
Fax: 858-657-9816  
Email: [api-sales@teledyne.com](mailto:api-sales@teledyne.com)  
Website: <http://www.teledyne-api.com/>



## SAFETY MESSAGES

Your safety and the safety of others is very important. We have provided many important safety messages in this addendum. Please read these messages carefully.

A safety message alerts you to potential hazards that could hurt you or others. Each safety message is associated with a safety alert symbol. These symbols are found in the manual and inside the instrument. The definition of these symbols is described below:

	<b>GENERAL SAFETY HAZARD: Refer to the instructions for details on the specific hazard.</b>
	<b>CAUTION: Hot Surface Warning</b>
	<b>CAUTION: Electrical Shock Hazard</b>
	<b>TECHNICIAN SYMBOL: All operations marked with this symbol are to be performed by qualified maintenance personnel only.</b>

	<p style="text-align: center;"><b>CAUTION</b></p> <p><b>The analyzer should only be used for the purpose and in the manner described in this addendum. If you use the analyzer in a manner other than that for which it was intended, unpredictable behavior could ensue with possible hazardous consequences.</b></p>
---	--



# TABLE OF CONTENTS

<b>1. M100EH DOCUMENTATION</b>	<b>7</b>
1.1. Using This Manual Addendum	7
<b>2. SPECIFICATIONS, APPROVALS &amp; WARRANTY</b>	<b>9</b>
2.1. Specifications	9
2.2. CE Mark Compliance	10
2.3. Warranty	10
<b>3. GETTING STARTED</b>	<b>13</b>
3.1. Unpacking and Initial Setup	13
3.1.1. Electrical Connections	14
3.1.1.1. External Pump	14
3.2. Pneumatic Connections	15
3.2.1.1. Pneumatic Connections to M100EH Basic Configuration	15
3.2.1.2. Connections with Internal Valve Options Installed	16
3.2.2. M100EH Layout	16
3.3. Initial Operation	18
3.3.1. Warning Messages	18
3.3.2. Test Functions	18
3.3.3. Interferents for SO <sub>2</sub> Measurements	19
<b>4. FREQUENTLY ASKED QUESTIONS</b>	<b>21</b>
<b>5. OPTIONAL HARDWARE AND SOFTWARE</b>	<b>23</b>
5.1. Zero/Span Valves (Option 50)	23
5.2. Internal Zero/Span Gas Generator (Option 51)	23
5.3. Zero and Two Span Point Valve Option (OPT 52)	24
5.4. Hydrocarbon Kicker Option (OPT 65)	25
<b>6. OPERATING INSTRUCTIONS</b>	<b>27</b>
6.1. Warning Messages	27
6.2. Test Functions	27
6.2.1. Test Channel Output	27
6.2.2. Range Units	28
6.2.3. Using the M100EH with a Hessen Protocol Network	28
6.2.4. Default iDAS Channels	29
6.2.5. Remote Operation Using the External Digital I/O	29
6.2.5.1. Status Outputs	29
6.2.5.2. Control Inputs	30
<b>7. CALIBRATION AND CALIBRATION CHECK PROCEDURES</b>	<b>31</b>
7.1. Manual Calibration with the Zero and Two Span Point Valve Option (OPT 52) installed	31
7.2. Manual Calibration Check with the Zero and Two Span Point Valve Option (OPT 52) installed	33
<b>8. INSTRUMENT MAINTENANCE</b>	<b>35</b>
8.1. Maintenance Schedule	35
8.2. Predictive Diagnostics	35
<b>9. THEORY OF OPERATION</b>	<b>37</b>
9.1. The UV Light Path	37
9.1.1. The Reference Detector	38
9.1.2. Direct Measurement Interferences	38
9.2. Pneumatic Operation	38
9.2.1. Sample Gas Flow	38
9.2.2. Pneumatic Sensors	39
9.2.2.1. Sample Pressure Sensor	39
9.2.2.2. Vacuum Pressure Sensor	39
9.2.2.3. Sample Flow Calculation	40
9.3. Electronic Operation	41
<b>10. TROUBLESHOOTING &amp; REPAIR</b>	<b>43</b>
10.1.1. Fault Diagnosis with Warning Messages	43
10.1.2. Fault Diagnosis with Test Functions	43
10.2. Subsystem Checkout	43
10.2.1. Pneumatic Sensor Assembly	43
10.3. Repair Procedures	44

10.3.1. Repairing the Sample Gas Flow Control Assembly .....	44
10.3.2. Sensor Module Repair & Cleaning .....	45
10.3.2.1. Adjusting the UV Lamp ( <i>Peaking the Lamp</i> ) .....	46
10.3.2.2. PMT Hardware Calibration ( <i>FACTORY CAL</i> ) .....	48
10.4. Technical Assistance .....	50

## LIST OF FIGURES

Figure 3-1: Example of Pneumatic Connections to M100EH External Pump .....	15
Figure 3-2: Pneumatic Connections to M100EH with Zero and Two Span Point Valve Option .....	16
Figure 3-3: Internal Pneumatic flow for M100EH in Basic Configuration .....	16
Figure 3-4: M100EH Layout (Basic Unit – No Valve Options) .....	17
Figure 5-1: Pneumatic Diagram of the M100EH With Z/S Option Installed. ....	23
Figure 5-2: Pneumatic Diagram of the M100EH With 2-Span Point Option Installed .....	24
Figure 5-3: Hydrocarbon Scrubber (Kicker) – OPT 65 .....	25
Figure 5-4: M100EH Internal Pneumatic Diagram with Hydrocarbon Scrubber Installed. ....	26
Figure 6-1: Control Input Connector .....	30
Figure 9-1: UV Light Path .....	37
Figure 9-2: Pneumatic Diagram of the M100EH – Base Configuration .....	39
Figure 9-3: M100EH Electronic Block Diagram .....	41
Figure 9-4: M100EH Power Distribution Block Diagram .....	42
Figure 10-1: Flow Control Assembly .....	44
Figure 10-2: Sensor Module Wiring and Pneumatic Fittings .....	45
Figure 10-3: Shutter Assembly - Exploded View .....	46
Figure 10-4: Location of UV Reference Detector Potentiometer .....	47
Figure 10-5: Pre-Amplifier Board Layout .....	48

## LIST OF TABLES

Table 2-1: Model 100EH Basic Unit Specifications .....	9
Table 3-1: Inlet / Outlet Connector Nomenclature .....	15
Table 2-1: Possible Warning Messages at Start-Up .....	18
Table 5-1: Two-Point Span Valve Operating States .....	25
Table 6-1: Additional M101EH Warning Messages .....	27
Table 6-2: Additional M100EH Test Functions .....	27
Table 6-3: Additional M101EH Test Parameters Available for Analog Output A3 .....	27
Table 6-4: M100EH Default Hessen Status Bit Assignments .....	28
Table 6-5: Status Output Signals .....	29
Table 6-6: Control Input Signals .....	30
Table 9-2: Predictive Uses for Test Functions .....	35
Table 10-1: Warning Messages - Indicated Failures .....	43
Table 10-2: Test Functions - Possible Causes for Out-Of-Range Values .....	43
Table 10-3: Example of HVPS Power Supply Outputs .....	47

## **LIST OF APPENDICES**

### **APPENDIX A - VERSION SPECIFIC SOFTWARE DOCUMENTATION**

**APPENDIX A-1: M100EH Software Menu Trees, Revision C.0**

**APPENDIX A-2: Setup Variables For Serial I/O, Revision C.0**

**APPENDIX A-3: Warnings and Test Functions, Revision C.0**

**APPENDIX A-4: M100EH Signal I/O Definitions, Revision C.0**

**APPENDIX A-5: M100EH iDAS Functions, Revision C.0**

**APPENDIX A-6: Terminal Command Designators, Revision C.0**

**APPENDIX B - M100EH SPARE PARTS LIST**

**APPENDIX C - REPAIR QUESTIONNAIRE - M100E**

**APPENDIX D - ELECTRONIC SCHEMATICS**

---

## **USER NOTES:**



# 1. M100EH DOCUMENTATION

## NOTE

Throughout this addendum, words printed in capital, bold letters, such as **SETUP** or **ENTR** represent messages as they appear on the analyzer's front panel display

## NOTE

The flowcharts in this addendum contain typical representations of the analyzer's display during the various operations being described. These representations are not intended to be exact and may differ slightly from the actual display of your instrument.

Thank you for purchasing the Model 100EH UV Fluorescence SO<sub>2</sub> Analyzer!

The documentation for this instrument is available in either printed format or in electronic format on a CD-ROM.

The electronic manual is in Adobe® Systems Inc. "Portable Document Format". The Adobe® Acrobat Reader® software, which is necessary to view these files, can be downloaded for free from the internet at <http://www.adobe.com/>.

The electronic version of the manual has many advantages:

- Keyword and phrase search feature
- Figures, tables and internet addresses are linked so that clicking on the item will display the associated feature or open the website.
- A list of chapters and sections as well as thumbnails of each page are displayed to the left of the text.
- Entries in the table of contents are linked to the corresponding locations in the manual.
- Ability to print sections (or all) of the manual

Additional documentation for the Model 100EH UV Fluorescence SO<sub>2</sub> Analyzer is available from Teledyne Instruments' website at <http://www.teledyne-api.com/manuals/>

- APICOM software manual, part number 03945
- Multi-drop manual, part number 01842
- DAS Manual, part number 02837.

## 1.1. Using This Manual Addendum

This manual addendum has the same overall structure as that of the M100E operator's manual, to simplify referring between the two. The manual has the following sections:

**Table of Contents:**

Outlines the contents of the addendum in the order the information is presented. This is a good overview of the topics covered in the manual. There is also a list of tables, a list of figures and a list of appendices.

**Specifications and Warranty**

This section contains a list of the analyzer's performance specifications, a description of the conditions and configuration under which EPA equivalency was approved and Teledyne Instrument's warranty statement.

**Getting Started:**

A concise set of instructions for setting up, installing and running your analyzer for the first time.

**FAQ:**

Answers to the most frequently asked questions about operating the analyzer.

**Optional Hardware & Software**

A description of optional equipment to add functionality to your analyzer.

**Operation Instructions**

This section includes step by step instructions for operating the analyzer and using its various features and functions.

**Calibration Procedures**

General information and step by step instructions for calibrating your analyzer.

**Instrument Maintenance**

Description of preventative maintenance procedures that should be regularly performed on you instrument to assure good operating condition.

**Theory of Operation**

This section describes the aspects of M100EH operation that differ from the M100E manual.

**Maintenance & Troubleshooting Section:**

This section includes pointers and instructions for diagnosing problems that are specific to the M100EH. The M100E manual has a more complete troubleshooting section, most of which also applies to the M100EH.

**Appendices:**

For easier access and better updating, some information has been separated out of the manual and placed in a series of appendices at the end of this addendum. These include: software menu trees, warning messages, definitions of iDAS & serial I/O variables, spare parts list, repair questionnaire, interconnect listing and drawings, and electronic schematics.

## 2. SPECIFICATIONS, APPROVALS & WARRANTY

### 2.1. Specifications

Table 2-1: Model 100EH Basic Unit Specifications

Min/Max Range (Physical Analog Output)	In 1ppb increments from 10ppm to 5,000 ppm, dual ranges or auto ranging
Measurement Units	ppm, mg/m3 (user selectable)
Zero Noise <sup>1</sup>	0.05 ppm rms
Span Noise <sup>1</sup>	< 0.5% of reading (above 50 ppm)
Lower Detectable Limit <sup>2</sup>	0.1 ppm rms
Zero Drift (24 hours)	< 1 ppm
Zero Drift (7 days)	< 2 ppm
Span Drift (7 Days)	< 0.5% FS
Linearity	1% of full scale
Precision	0.5% of reading <sup>1</sup>
Temperature Coefficient	< 0.1% per °C
Voltage Coefficient	< 0.05% per V
Lag Time <sup>1</sup>	5 sec
Rise/Fall Time <sup>1</sup>	95% in < 30 sec
Sample Flow Rate	700 cm <sup>3</sup> /min. ±10%
Temperature Range	5-40°C
Humidity Range	0 - 95% RH, non-condensing
Dimensions H x W x D	7" x 17" x 23.5" (178 mm x 432 mm x 597 mm)
Weight, Analyzer (Basic Configuration)	45 lbs (20.5 kg) w/internal pump
Weight, Pump Pack	16 lbs (7 kg)
AC Power Rating	100 V, 50/60 Hz (3.25A); 115 V, 60 Hz (3.0 A); 220 – 240 V, 50/60 Hz (2.5 A)
Environmental	Installation category (over-voltage category) II; Pollution degree 2
Analog Outputs	Three (3) Outputs
Analog Output Ranges	100 mV, 1 V, 5 V, 10 V, 2-20 or 4-20 mA isolated current loop. All Ranges with 5% Under/Over Range
Analog Output Resolution	1 part in 4096 of selected full-scale voltage
Status Outputs	8 Status outputs from opto-isolators
Control Inputs	6 Control Inputs, 3 defined, 3 spare
Serial I/O	One (1) RS-232; One (1) RS-485 (2 connectors in parallel) Baud Rate : 300 – 115200: Optional Ethernet Interface
Certifications	EN61326 (1997 w/A1: 98) Class A, FCC Part 15 Subpart B Section 15.107 Class A, ICES-003 Class A (ANSI C63.4 1992) & AS/NZS 3548 (w/A1 & A2; 97) Class A. IEC 61010-1:90 + A1:92 + A2:95,
<p>1 As defined by the USEPA.            2 Defined as twice the zero noise level by the USEPA.</p>	

## 2.2. CE Mark Compliance

### Emissions Compliance

The Teledyne-Advanced Pollution Instrumentation UV Fluorescence SO<sub>2</sub> Analyzer M100EH was tested and found to be fully compliant with:

EN61326 (1997 w/A1: 98) Class A, FCC Part 15 Subpart B Section 15.107 Class A, ICES-003 Class A (ANSI C63.4 1992) & AS/NZS 3548 (w/A1 & A2; 97) Class A.

Tested on 21 February 2003 - 08 March 2003 at CKC Laboratories, Inc., Report Number CE03-021A.

### Safety Compliance

The Teledyne-Advanced Pollution Instrumentation UV Fluorescence SO<sub>2</sub> Analyzer M100EH was tested and found to be fully compliant with:

IEC 61010-1:90 + A1:92 + A2:95,

Issued by CKC Laboratories on 4 April 2003, Report Number WO-80146.

## 2.3. Warranty

### WARRANTY POLICY (02024D)

Prior to shipment, T-API equipment is thoroughly inspected and tested. Should equipment failure occur, T-API assures its customers that prompt service and support will be available.

### COVERAGE

After the warranty period and throughout the equipment lifetime, T-API stands ready to provide on-site or in-plant service at reasonable rates similar to those of other manufacturers in the industry. All maintenance and the first level of field troubleshooting is to be performed by the customer.

### NON-API MANUFACTURED EQUIPMENT

Equipment provided but not manufactured by T-API is warranted and will be repaired to the extent and according to the current terms and conditions of the respective equipment manufacturers warranty.

### GENERAL

During the warranty period, T-API warrants each Product manufactured by T-API to be free from defects in material and workmanship under normal use and service. Expendable parts are excluded.

If a Product fails to conform to its specifications within the warranty period, API shall correct such defect by, in API's discretion, repairing or replacing such defective Product or refunding the purchase price of such Product.

The warranties set forth in this section shall be of no force or effect with respect to any Product: (i) that has been altered or subjected to misuse, negligence or accident, or (ii) that has been used in any manner other than in accordance with the instruction provided by T-API, or (iii) not properly maintained.

THE WARRANTIES SET FORTH IN THIS SECTION AND THE REMEDIES THEREFORE ARE EXCLUSIVE AND IN LIEU OF ANY IMPLIED WARRANTIES OF MERCHANTABILITY, FITNESS FOR PARTICULAR PURPOSE OR OTHER WARRANTY OF QUALITY, WHETHER EXPRESSED OR IMPLIED. THE REMEDIES SET FORTH IN THIS SECTION ARE THE EXCLUSIVE REMEDIES FOR BREACH OF ANY WARRANTY CONTAINED HEREIN. API SHALL NOT BE LIABLE FOR ANY INCIDENTAL OR CONSEQUENTIAL DAMAGES ARISING OUT OF OR RELATED TO THIS AGREEMENT OF T-API'S PERFORMANCE HEREUNDER, WHETHER FOR BREACH OF WARRANTY OR OTHERWISE

**Terms and Conditions**

All units or components returned to T-API should be properly packed for handling and returned freight prepaid to the nearest designated Service Center. After the repair, the equipment will be returned, freight prepaid.



## 3. GETTING STARTED

### 3.1. Unpacking and Initial Setup



#### CAUTION

To avoid personal injury, always use two persons to lift and carry the Model 100EH.

1. Inspect the received packages for external shipping damage. If damaged, please advise the shipper first, then T-API.
2. Included with your analyzer is a printed record (Form number 04989) of the final performance characterization performed on your instrument at the factory. This record is an important quality assurance and calibration record for this instrument. It should be placed in the quality records file for this instrument.
3. Carefully remove the top cover of the analyzer and check for internal shipping damage.
  - Remove the set screw located in the top, center of the rear panel
  - Remove the screws fastening the top cover to the unit (four per side).
  - Lift the cover straight up.

**NOTE**

Printed circuit assemblies (PCAs) are sensitive to electro-static discharges too small to be felt by the human nervous system. Failure to use ESD protection when working with electronic assemblies will void the instrument warranty.

See Chapter 12 of the M100E Manual (P/N 04515) for more information on preventing ESD damage.

**CAUTION**

Never disconnect electronic circuit boards, wiring harnesses or electronic subassemblies while the unit is under power.

4. Inspect the interior of the instrument to make sure all circuit boards and other components are in good shape and properly seated.
5. Check the connectors of the various internal wiring harnesses and pneumatic hoses to make sure they are firmly and properly seated.
6. Verify that all of the optional hardware ordered with the unit has been installed. These are checked on the paperwork (Form 04989) accompanying the analyzer.

**3.1.1. Electrical Connections:**

For full details on the electrical connections of the M100EH, please refer to the M100E user's manual (#04515), Chapter 3.

**3.1.1.1. External Pump**

The M100EH is equipped with an external pneumatic pump. This pump is powered separately from the instrument via it's own power cord. The pump has no ON/OFF switch and should begin operating as soon as it is plugged into a live power supply.

**CAUTION**

- Check the voltage / frequency label on the rear panel of the instrument and on the external pump for compatibility with the local power. Do not plug in either the analyzer or the pump unless the voltages or frequencies are correct.
- Power connection must have a functioning ground connection. Do not defeat the ground wire on power plug.
- Turn off analyzer power before disconnecting or connecting electrical subassemblies.
- Do not operate with cover off.

## 3.2. Pneumatic Connections:

**NOTE**

To prevent dust from getting into the analyzer, it was shipped with small plugs inserted into each of the pneumatic fittings on the rear panel. Make sure that all dust plugs are removed before attaching exhaust and supply gas lines.

**Table 3-1: Inlet / Outlet Connector Nomenclature**

REAR PANEL LABEL	FUNCTION
Sample	Connects the sample gas to the analyzer. When operating the analyzer without zero span option, this is also the inlet for any calibration gases.
Exhaust	Connect an exhaust gas line to this port to the inlet of the external pump.
Zero Air	On Units with zero/span valve option installed, this port connects the zero air gas or the zero air cartridge to the analyzer.

Figure 3-5 of the M100E Manual (P/N 04515) shows the internal pneumatic flow of the M100E in its standard configuration. For a diagram of the internal pneumatic flow of the M100EH, see Figure 3-2 of this addendum.

### 3.2.1.1. Pneumatic Connections to M100EH Basic Configuration:

The pneumatic connections for the M100EH analyzer in its basic configuration are nearly identical to those described the M100E Manual (P/N 04515) Section 3.1.2.2 except that the M100EH has an external pump. Therefore:

- A pneumatic line of 1/4" PTFE must be attached between the analyzer's exhaust port and the inlet port of the pump.
- The exhaust from must be vented outside the shelter or immediate area surrounding the instrument using a maximum of 10 meters of 1/4" PTFE tubing.

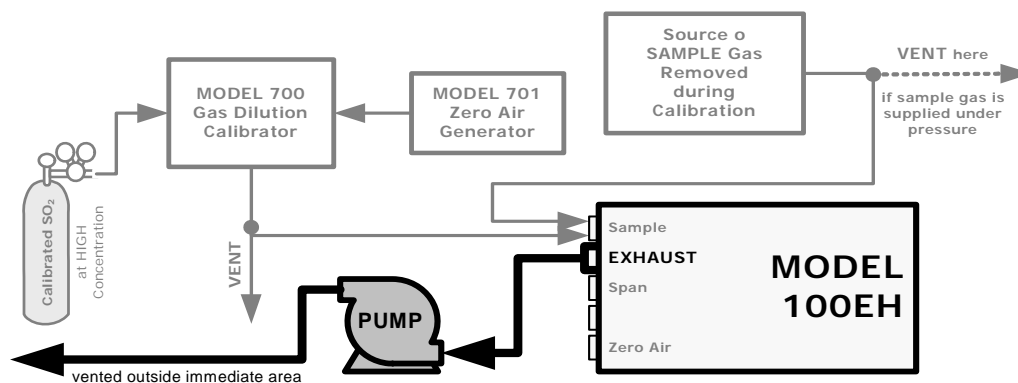

**Figure 3-1: Example of Pneumatic Connections to M100EH External Pump**

This change is true for all configurations and variations of the M100EH.

### 3.2.1.2. Connections with Internal Valve Options Installed

- There is no IZS option available for the M100EH .
- An additional valve option (Option 52 - Zero & Two Span Points) is available on the M100EH. The pneumatic set up for this option is:

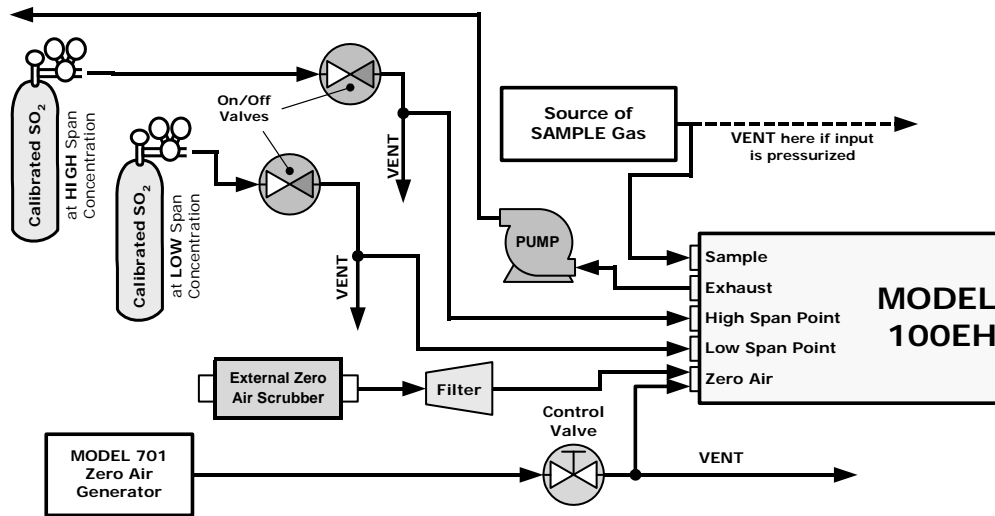

Figure 3-2: Pneumatic Connections to M100EH with Zero and Two Span Point Valve Option

### 3.2.2. M100EH Layout

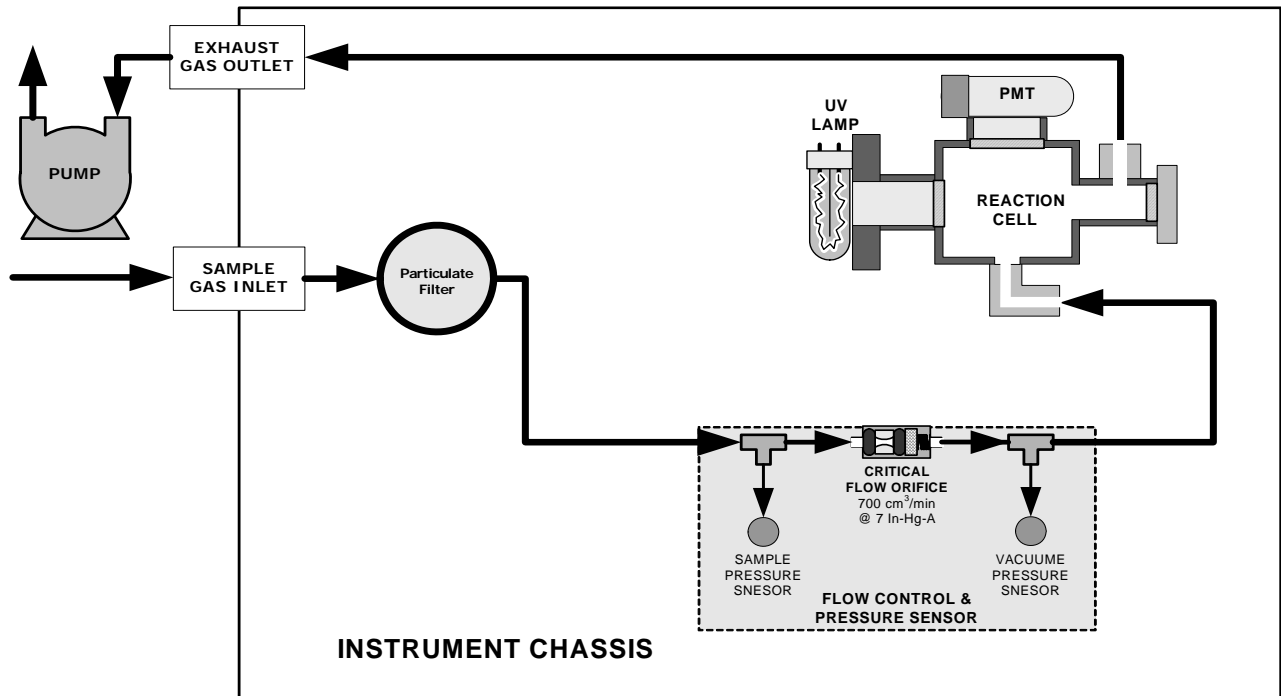

Figure 3-3: Internal Pneumatic flow for M100EH in Basic Configuration

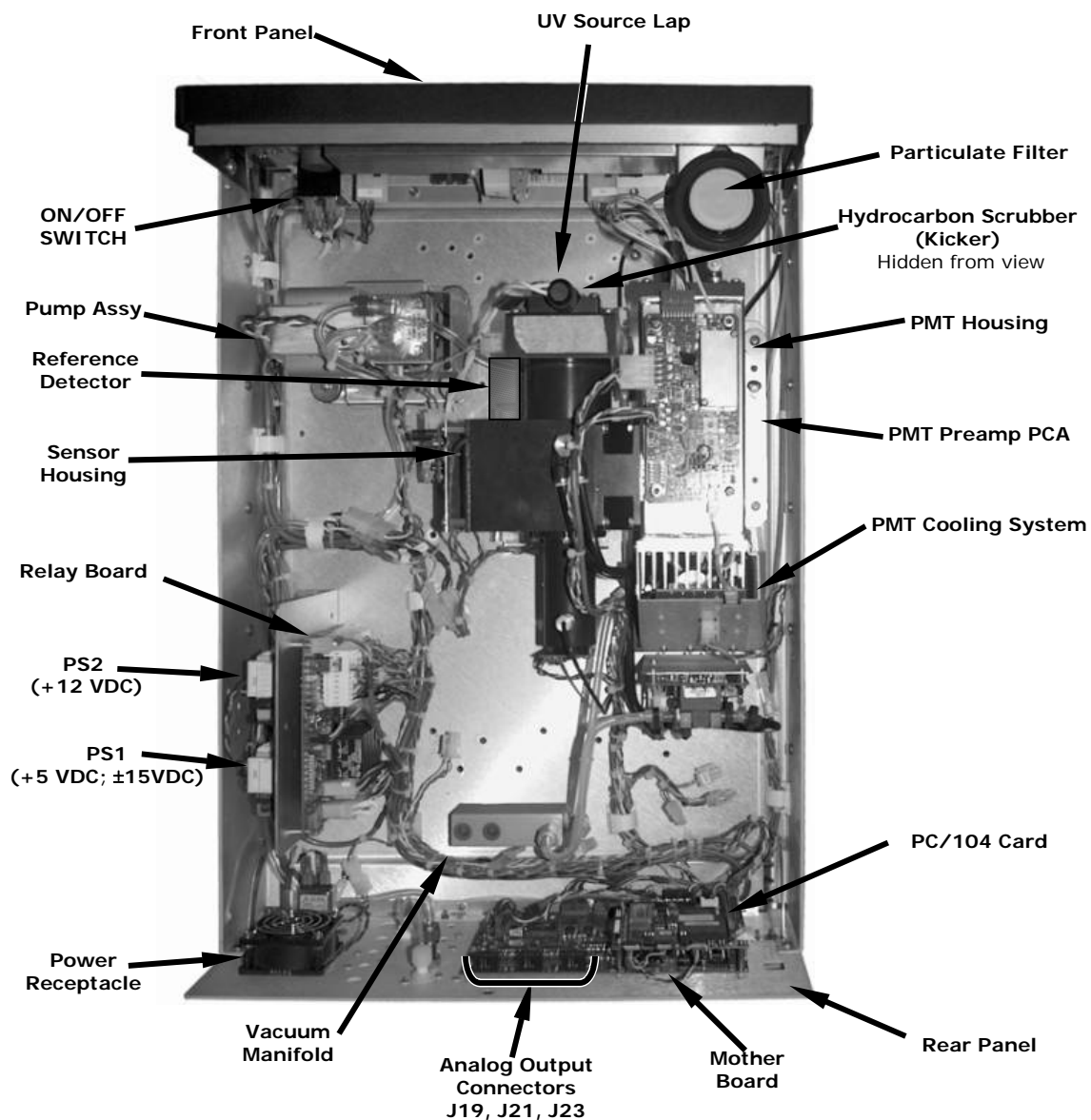

Figure 3-4: M100EH Layout (Basic Unit – No Valve Options)

### 3.3. Initial Operation

With the following exceptions, the operation of the M100EH is nearly identical to that of the M100E. Please refer to the M100E User's Manual, Chapter 3, for details on initial operation, including common warning messages, functional checkout of the instrument, initial calibration and common interferences for the M100EH.

#### 3.3.1. Warning Messages

Please refer to the M100E User's Manual (04515), Chapter 3, for a complete listing of warnings for the M100EH. The following table lists warnings that differ in the M100EH from those described in the M100E manual.

Table 2-1: Possible Warning Messages at Start-Up

MESSAGE	MEANING
Vacuum Pressure Warning	The vacuum pressure reading is out of it's allowed range. The pump may have failed, or the instrument may have a leak or obstruction in the flow path.

#### 3.3.2. Test Functions

Check to make sure that the analyzer is functioning within allowable operating parameters As described in Section 3.2.4 of the M100E Manual (P/N 04515). The available test functions for the M100EH is:

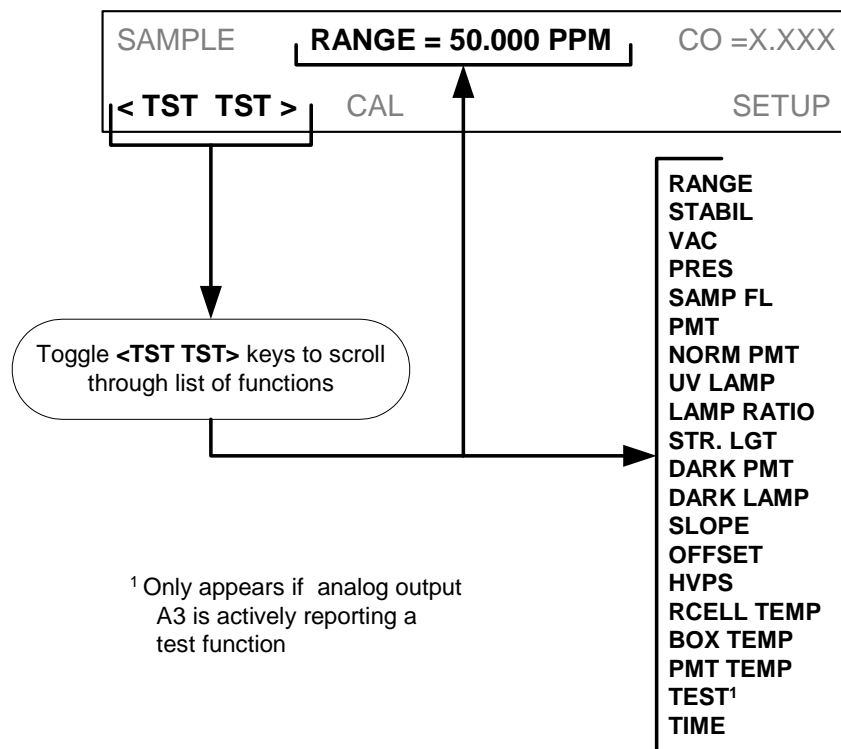

### **3.3.3. Interferents for SO<sub>2</sub> Measurements**

Hydrocarbons are a significant interferent for UV fluorescent SO<sub>2</sub> measurements, however, the typical M100EH application does not have hydrocarbons in the sample stream. Therefore, in order to reduce cost to the customer, the M100EH in its standard configuration does not include a hydrocarbon kicker/scrubber.

If your application includes hydrocarbons in the sample gas stream, it is very important that they be removed from the sample gas prior to the it entering the analyzer's sample chamber. A hydrocarbon Kicker Option (OPT 65) package (see Section 5 below) is available for this purpose.



## 4. FREQUENTLY ASKED QUESTIONS

**Q:** How long does the sample pump last?

**A:** The sample pump should last about one year and the pump diaphragms should to be replaced annually or when necessary.

To determine if the diaphragm on a M100EH needs replacing check the **VAC** test function (instead of the **PRES** function as described in the M100E Manual - P/N 04515). If the **VAC** value is > 10 in-Hg-A, the diaphragm should be replaced.



## 5. OPTIONAL HARDWARE AND SOFTWARE

With the following additions, changes and exceptions, the options listed in Chapter 5 of the M100E Manual (P/N 04515) are also available for the M100EH.

### 5.1. Zero/Span Valves (Option 50)

The M100EH zero/span valve option is identical to that of the M100E in respect to operation and valve states (see Table 5-1 of the M100E Manual). The internal pneumatic connections are slightly different.

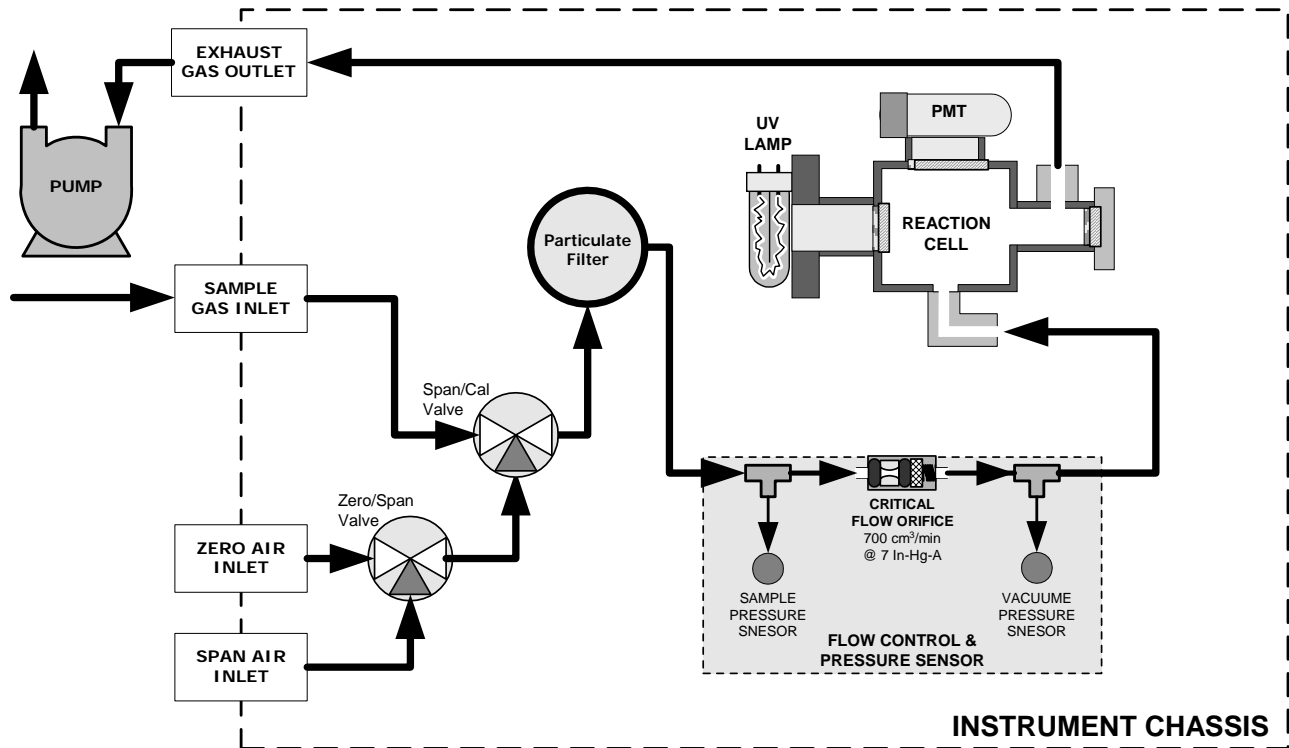

Figure 5-1: Pneumatic Diagram of the M100EH With Z/S Option Installed.

### 5.2. Internal Zero/Span Gas Generator (Option 51)

The IZS valve option (OPT 51) is not available for the M101EH.

### 5.3. Zero and Two Span Point Valve Option (OPT 52)

This option includes a special set of valves that allows two separate SO<sub>2</sub> mixtures to enter the analyzer from two independent sources. Typically these two gas mixtures will come from two, separate, pressurized bottles of certified calibration gas: one mixed to produce a SO<sub>2</sub> concentration equal to the expected span calibration value for the application and the other mixed to produce a concentration at or near the midpoint of the intended measurement range. Individual gas inlets, labeled HIGH SPAN and LOW SPAN are provided at the back on the analyzer.

The valves allow the user to switch between the two sources via keys on the front panel or from a remote location by way of either the analyzer's digital control inputs or by sending commands over it's serial I/O port(s).

**NOTE**

The analyzer's software only allows the **SLOPE** and **OFFSET** to be calculated when sample is being routed through the **HIGH SPAN** inlet.

The **LOW SPAN** gas is for midpoint reference checks only.

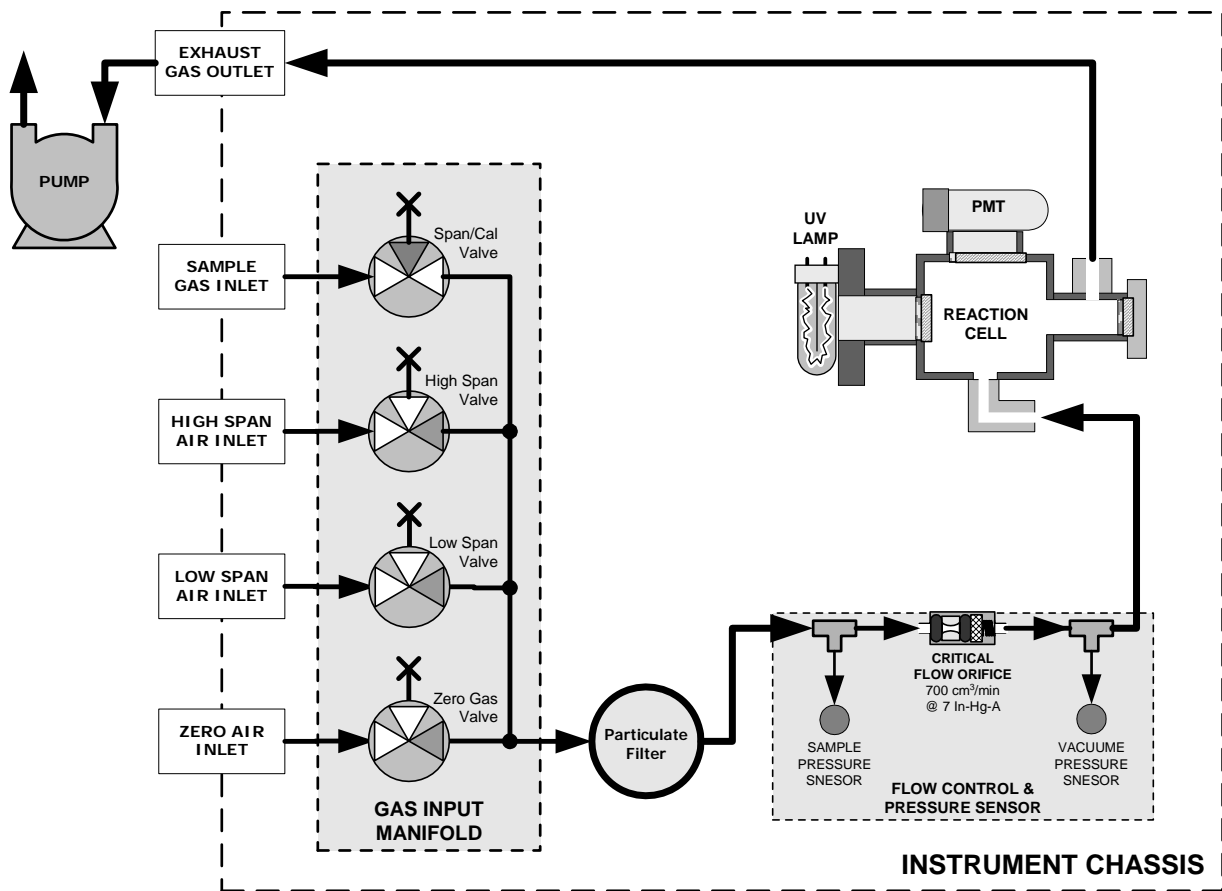

Figure 5-2: Pneumatic Diagram of the M100EH With 2-Span Point Option Installed.

Table 5-1 describes the state of each valve during the analyzer's various operational modes.

**Table 5-1: Two-Point Span Valve Operating States**

MODE	VALVE	CONDITION
<b>SAMPLE</b>	Sample/Cal	<b>Open to SAMPLE inlet</b>
	Zero Gas Valve	Closed to ZERO AIR inlet
	High Span Valve	Closed to HIGH SPAN inlet
	Low Span Valve	Closed to LOW SPAN inlet
<b>ZERO CAL</b>	Sample/Cal	Closed to SAMPLE inlet
	Zero Gas Valve	<b>Open to ZERO AIR inlet</b>
	High Span Valve	Closed to HIGH SPAN inlet
	Low Span Valve	Closed to LOW SPAN inlet
<b>HIGH SPAN CAL</b>	Sample/Cal	Closed to SAMPLE inlet
	Zero Gas Valve	Closed to ZERO AIR inlet
	High Span Valve	<b>Open to HIGH SPAN inlet</b>
	Low Span Valve	Closed to LOW SPAN inlet
<b>Low Span Check</b>	Sample/Cal	Closed to SAMPLE inlet
	Zero Gas Valve	Closed to ZERO AIR inlet
	High Span Valve	Closed to HIGH SPAN inlet
	Low Span Valve	<b>Open to LOW SPAN inlet</b>

## 5.4. Hydrocarbon Kicker Option (OPT 65)

This option is specifically designed for those applications where hydrocarbons are present in the sample gas stream. It includes an internal, scrubber consisting of a tube of a specialized plastic that absorbs hydrocarbons very well located within an outer flexible plastic tube shell.

As gas flows through the inner tube, hydrocarbons are absorbed into the membrane walls, and transported through the membrane wall and into the hydrocarbon free, purge gas flowing through the outer tube (see Figure 5-3). This process is driven by the hydrocarbon concentration gradient between the inner and outer of the tubes.

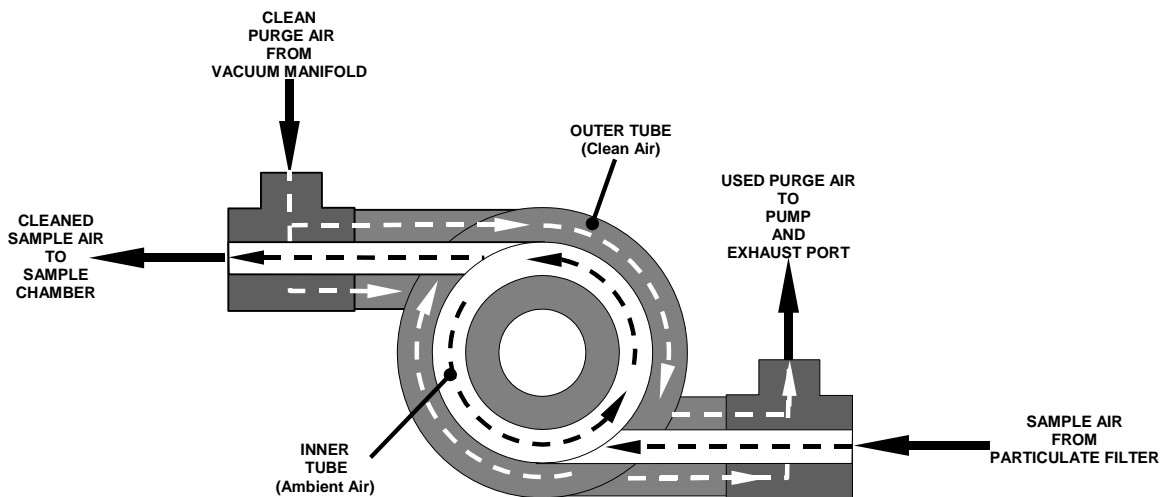

**Figure 5-3: Hydrocarbon Scrubber (Kicker) – OPT 65**

The scrubbed air from the inner tube is returned to be used as the purge gas in the outer tube after it passes through the analyzer's reaction cell. This means that when the analyzer is first started, the concentration gradient between the inner and outer tubes is small and the scrubber's efficiency is relatively low. When the instrument is turned on after having been off for more than 30 minutes, it takes a certain amount of time for the gradient to become large enough for the scrubber to adequately remove hydrocarbons from the sample air.

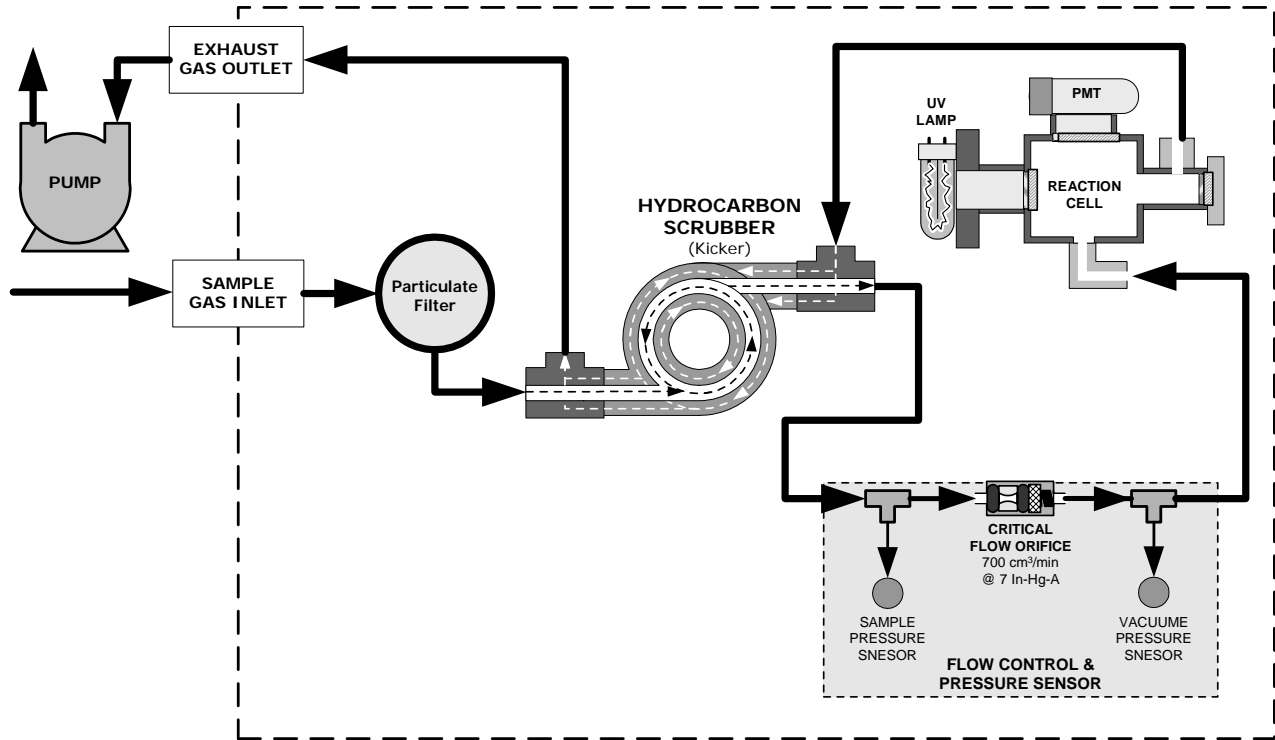

Figure 5-4: M100EH Internal Pneumatic Diagram with Hydrocarbon Scrubber Installed.

## 6. OPERATING INSTRUCTIONS

### 6.1. Warning Messages

Please refer to the M100E User's Manual (04515), Chapter 3, for a complete listing of warnings for the M100EH. The following table lists warnings that differ in the M100EH from those described in the M100E manual.

**Table 6-1: Additional M101EH Warning Messages**

MESSAGE	MEANING
Vacuum Pressure Warning	The vacuum pressure reading is out of its allowed range. The pump may have failed, or the instrument may have a leak or obstruction in the flow path.

### 6.2. Test Functions

Please refer to the M100E Manual (04515), Chapter 6, for a complete list of test functions for the M100EH. The following table lists test functions that are in addition to or differ from those listed there.

**Table 6-2: Additional M100EH Test Functions**

DISPLAY	PARAMETER	UNITS	DESCRIPTION
VAC	Vacuum Pressure	In-Hg-A	The actual pressure measured on the vacuum side of the M100EH's critical flow orifice. This is the pressure of the gas in the instrument's sample chamber.
PRES	Sample GAS Pressure	in-Hg-A	The current pressure of the sample gas as it enters the sample inlet at the back of the analyzer, but upstream of the critical flow orifice and before the gas enters the reaction cell.

#### 6.2.1. Test Channel Output

When activated, output channel **A3** can be used to report one of the test functions viewable from the SAMPLE mode display. To activate the A3 channel and select a test function, follow instructions in Section 6.9.10 of the M100E Manual (P/N 04515).

The following table lists test functions that are in addition to or differ from those listed in Table 6-14 of the M100E Manual.

**Table 6-3: Additional M101EH Test Parameters Available for Analog Output A3**

TEST CHANNEL	TEST PARAMETER RANGE
VACUUM PRESSURE	0-40 in-Hg-A

## 6.2.2. Range Units

The M100EH only displays concentrations in parts per million ( $10^6$  mols per mol, **PPM**) or milligrams per cubic meter ( $\text{mg}/\text{m}^3$ , **MGM**).

- NOT AVAILABLE: Parts per billion ( $10^9$  mols per mol, **PPB**) and micrograms per cubic meter ( $\mu\text{g}/\text{m}^3$ , **UGM**).

To change the concentration units of the M100EH follow the instructions found in Section 6.7.7 of the M100E Manual.

## 6.2.3. Using the M100EH with a Hessen Protocol Network

The set up and use of the M100EH in Hessen protocol networks is the same as described in Section 6.12.4 of the M100E Manual (P/N 04515) except that there are minor differences in the status flags. The following table supercedes Table 6-27 of the M100E Manual.

**Table 6-4: M100EH Default Hessen Status Bit Assignments**

STATUS FLAG NAME	DEFAULT BIT ASSIGNMENT
<b>WARNING FLAGS</b>	
SAMPLE FLOW WARNING	0001
PMT DET WARNING	0002
UV LAMP WARNING	0002
HVPS WARNING	0004
DARK CAL WARNING	0008
RCELL TEMP WARNING	0010
PMT TEMP WARNING	0040
INVALID CONC	0080
<b>OPERATIONAL FLAGS</b>	
In Manual Calibration Mode	0200
In Zero Calibration Mode	0400
In Low Span Calibration Mode	0800
In Span Calibration Mode	0800
<b>UNITS OF MEASURE FLAGS</b>	
UGM <sup>1</sup>	0000
MGM	2000
PPB <sup>1</sup>	4000
PPM	6000
<b>SPARE/UNUSED BITS</b>	0020, 0100, 8000
<b>UNASSIGNED FLAGS</b>	
Box Temp Warning	System Reset
Sample Press Warning	Front Panel Warning
Vacuum Press Warning	Analog Cal Warning
Rear Board Not Detected	Cannot Dyn Zero
Relay Board Warning	Cannot Dyn Span
<sup>1</sup> Although assigned flags, these units are not available on the M100EH	

## 6.2.4. Default iDAS Channels

The default Data Channels included in the M101EH analyzer's software include the **CONC**, **PNUMT** & **CALDAT** channels. The **FAST** & **DETAIL** preset channels are not included.

## 6.2.5. Remote Operation Using the External Digital I/O

### 6.2.5.1. Status Outputs

The function and pin assignment5s for the m100EH digital status outputs are:.

Table 6-5: Status Output Signals

SATUS CONNECTOR PIN NUMBER <sup>1</sup>	STATUS DEFINITION	CONDITION
1	<b>SYSTEM OK</b>	ON if no faults are present.
2	<b>CONC VALID</b>	OFF any time the HOLD OFF feature is active, such as during calibration or when other faults exist possibly invalidating the current concentration measurement (example: sample flow rate is outside of acceptable limits). ON if concentration measurement is valid.
3	<b>HIGH RANGE</b>	ON if unit is in high range of the AUTO Range Mode
4	<b>ZERO CAL</b>	ON whenever the instrument's ZERO point is being calibrated.
5	<b>HIGH SPAN CAL</b>	ON whenever the instrument is set for <b>DUAL</b> or <b>AUTO</b> reporting range mode an it's high range span point is being calibrated .
6	<b>DIAG MODE</b>	ON whenever the instrument is in DIAGNOSTIC mode
7	<b>LOW SPAN CAL</b>	ON whenever the instrument is set for <b>DUAL</b> or <b>AUTO</b> reporting range mode an it's lows range span point is being calibrated .
8	<b>SPARE</b>	
D	<b>EMITTER BUS</b>	The emitters of the transistors on pins 1-8 are bussed together.
	<b>SPARE</b>	
+	<b>DC POWER</b>	+ 5 VDC, 300 mA source (combined rating with Control Output, if used).
	<b>Digital Ground</b>	The ground level from the analyzer's internal DC power supplies

<sup>1</sup> Located on Rear Panel

### 6.2.5.2. Control Inputs

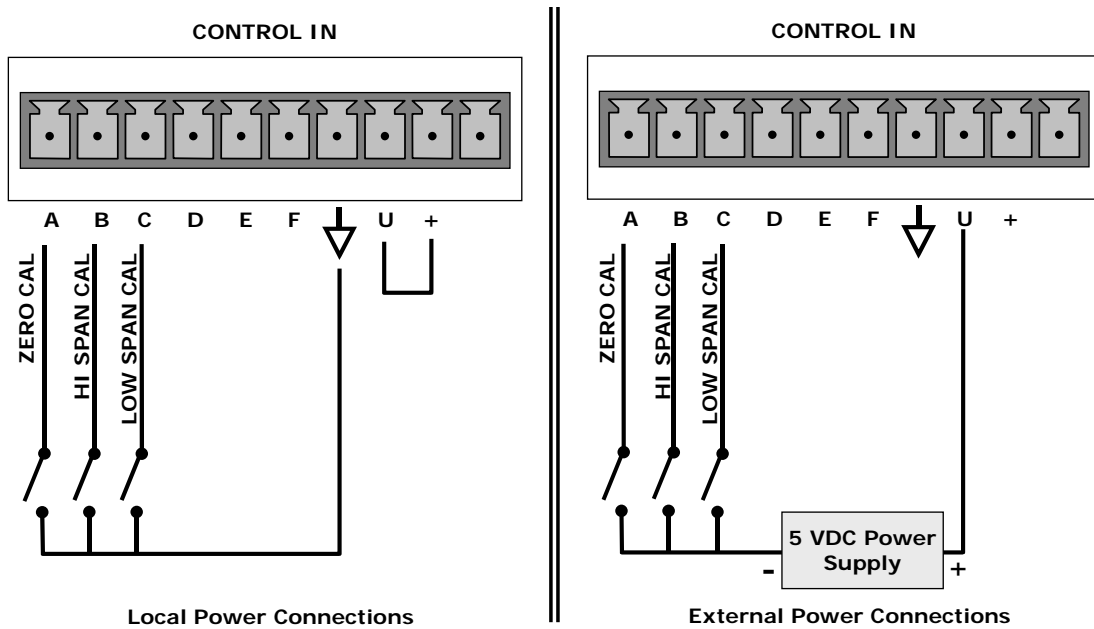

Figure 6-1: Control Input Connector

Table 6-6: Control Input Signals

INPUT #	STATUS DEFINITION	ON CONDITION
A	<b>REMOTE ZERO CAL</b>	The analyzer is placed in Zero Calibration mode. The mode field of the display will read ZERO CAL R.
B	<b>REMOTE HIGH SPAN CAL</b>	If the instrument is set for <b>DUAL</b> or <b>AUTO</b> reporting range mode, activating this input causes the analyzer to enter high range span calibration mode. The mode field of the display will read SPAN CAL R.
C	<b>REMOTE LO SPAN CAL</b>	The analyzer is placed in low span calibration mode as part of performing a low span (midpoint) calibration. The mode field of the display will read LO CAL R.
D, E & F	<b>SPARE</b>	
⏚	<b>Digital Ground</b>	The ground level from the analyzer's internal DC power supplies (same as chassis ground)
U	<b>External Power input</b>	Input pin for +5 VDC required to activate pins A – F.
+	<b>5 VDC output</b>	Internally generated 5V DC power. To activate inputs A – F, place a jumper between this pin and the "U" pin. The maximum amperage through this port is 300 mA (combined with the analog output supply, if used).

## 7. CALIBRATION AND CALIBRATION CHECK PROCEDURES

Calibration procedures for the M100EH are the same as those for the M100E. One exception to this statement is that the M100EH has a special valve option, Zero and Two Span Point Valve Option - OPT 52 (See Section 5.1), that allows a mid-span point be checked.

### 7.1. Manual Calibration with the Zero and Two Span Point Valve Option (OPT 52) installed.

**NOTE**

It is only possible to calibrate to the high span gas. The low span gas is only used for calibration checks.

Zero and Span calibrations using the Zero and two Span Valve option are similar to that described in Section 7.2, except that:

- Zero air and both span gas is supplied to the analyzer through the zero gas and span gas inlets rather than through the sample inlet.
- The zero and cal operations are initiated directly and independently with dedicated keys (**CALZ** & **CALS**)

**STEP ONE:** Connect the sources of zero air and span gas to the respective ports on the rear panel (see Figure 3-2 of this addendum).

**STEP TWO:** Set the expected SO<sub>2</sub> high span gas value:

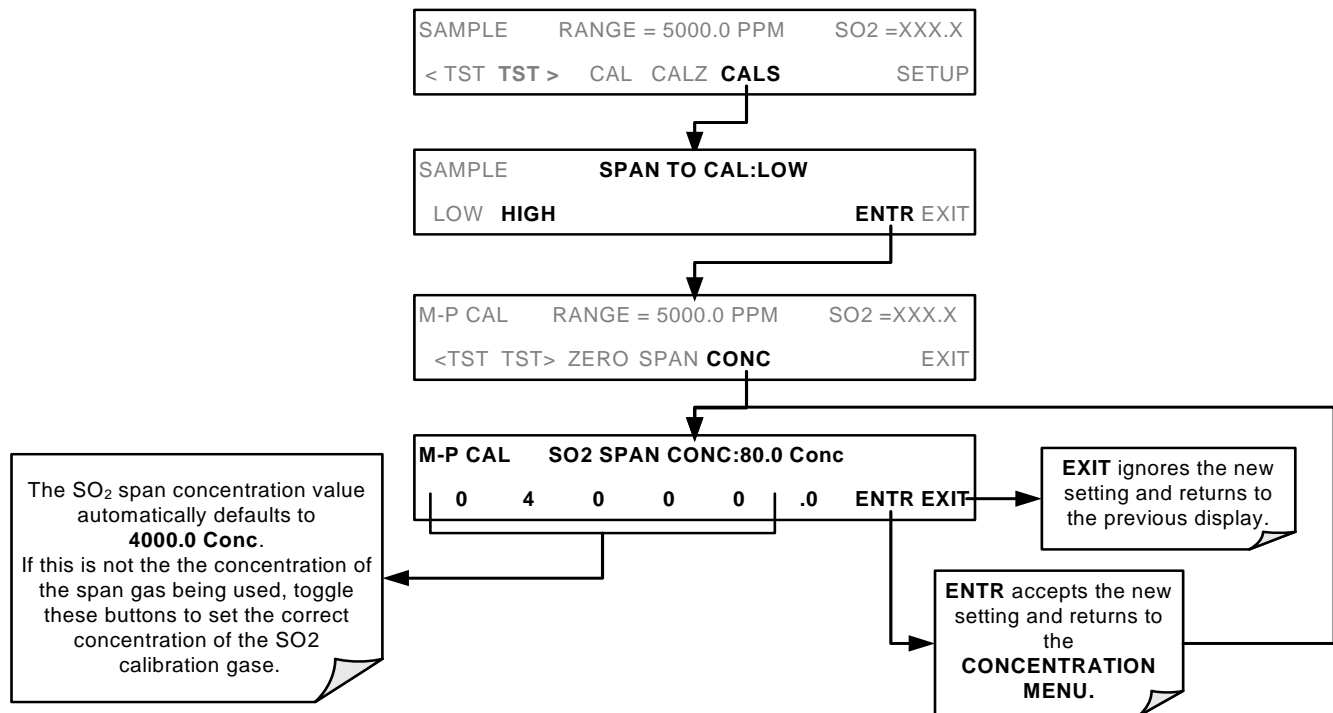

**STEP THREE:** Perform the calibration according to the following flow chart:

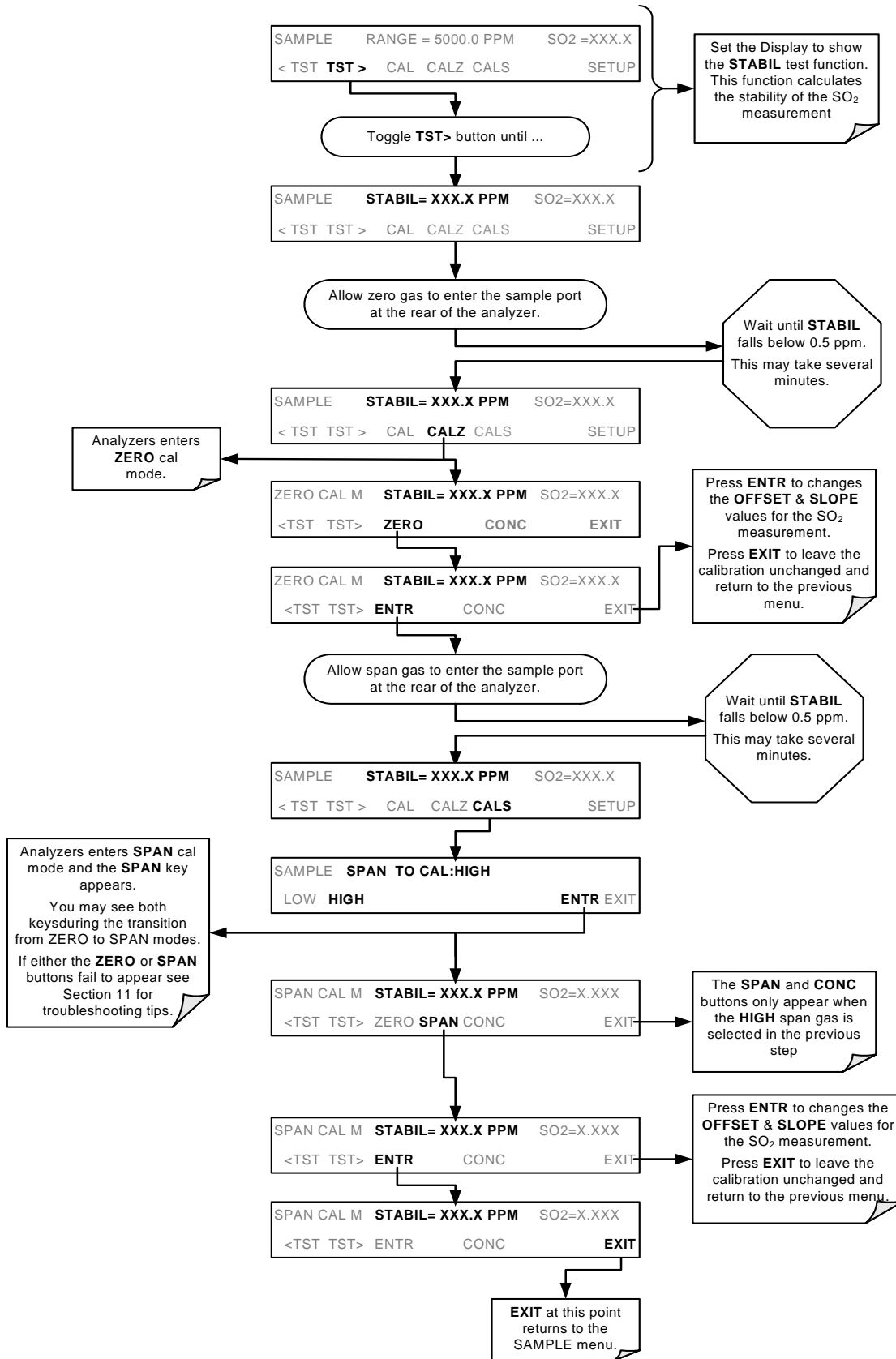

## 7.2. Manual Calibration Check with the Zero and Two Span Point Valve Option (OPT 52) installed.

Set up is identical to that shown in **STEP ONE** of the preceding section. To perform the zero/span check:

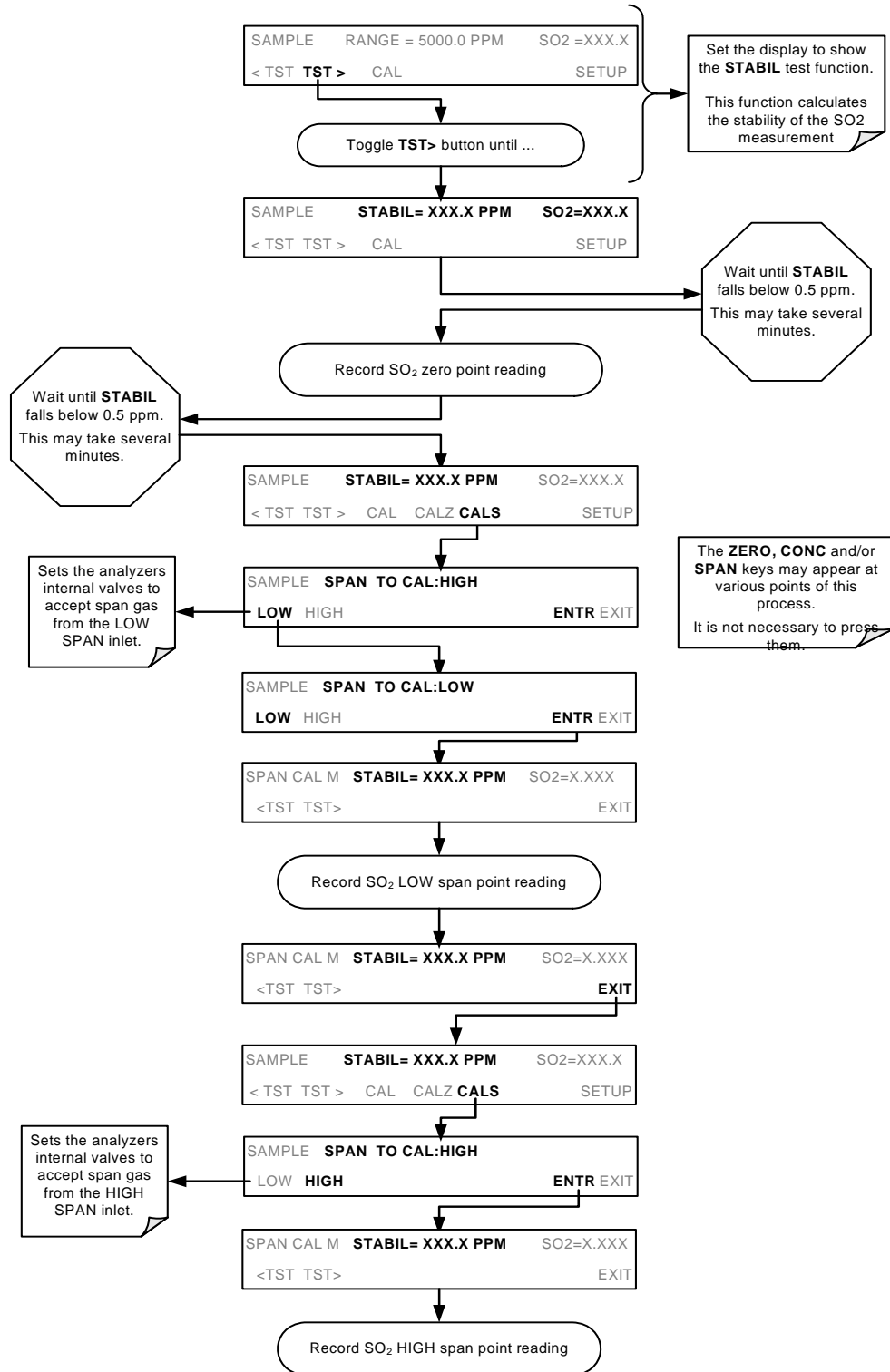



## 8. INSTRUMENT MAINTENANCE

### 8.1. Maintenance Schedule

There is no Internal IZS offered for the M100EH.

### 8.2. Predictive Diagnostics

Because the M100EH's internal pneumatics are monitored in a different manner than those of the M100E there are some differences in how the instruments test functions are used as predictive diagnostics. Table 8-1 of this addendum supersedes Table 9-2 of the M100E Manual

**Table 9-2: Predictive Uses for Test Functions**

TEST FUNCTION	iDAS FUNCTION	CONDITION	BEHAVIOR		INTERPRETATION
			EXPECTED	ACTUAL	
PRES	SMPPRS	Sample gas pressure upstream of the critical flow orifice.	Constant within atmospheric changes	Slowly increasing	<ul style="list-style-type: none"> <li>Flow path is clogging up.                             <ul style="list-style-type: none"> <li>- Check critical flow orifice &amp; sintered filter.</li> <li>- Replace particulate filter</li> </ul> </li> </ul>
				Slowly decreasing	<ul style="list-style-type: none"> <li>Developing leak in pneumatic system to vacuum (developing valve failure)</li> </ul>
PRES	SMPPRS	Sample gas pressure upstream of the critical flow orifice.	Constant within atmospheric changes	Slowly increasing	<ul style="list-style-type: none"> <li>Flow path is clogging up.                             <ul style="list-style-type: none"> <li>- Check critical flow orifice &amp; sintered filter.</li> <li>- Replace particulate filter</li> </ul> </li> </ul>
				Slowly decreasing	<ul style="list-style-type: none"> <li>Developing leak in pneumatic system to vacuum (developing valve failure)</li> </ul>
VAC	VACUUM	Gas pressure downstream of the critical flow orifice (e.g. inside reaction cell).	Constant within atmospheric changes	Fluctuating	<ul style="list-style-type: none"> <li>Developing leak in pneumatic system</li> </ul>
SAMP FL	SMPFLW	Standard Operation	Stable	Slowly Decreasing	<ul style="list-style-type: none"> <li>Flow path is clogging up.                             <ul style="list-style-type: none"> <li>- Check critical flow orifice &amp; sintered filter.</li> <li>- Replace particulate filter</li> </ul> </li> </ul>
DRK PMT	DRKPMT	PMT output when UV Lamp shutter closed	Constant within $\pm 20$ of check-out value	Significantly increasing	<ul style="list-style-type: none"> <li>PMT cooler failure</li> <li>Shutter Failure</li> </ul>
<i>SO<sub>2</sub></i> Concentration	CONC1	Standard configuration at span	stable for constant concentration	Decreasing over time	<ul style="list-style-type: none"> <li>Drift of instrument response; UV Lamp output is excessively low.</li> </ul>
				Fluctuating	<ul style="list-style-type: none"> <li>Leak in gas flow path.</li> </ul>
LAMP RATIO	LAMPR	Standard Operation	Stable and near 100%	Fluctuating or Slowly increasing	<ul style="list-style-type: none"> <li>UV detector wearing out</li> <li>UV source Filter developing pin holes</li> </ul>
				Slowly decreasing	<ul style="list-style-type: none"> <li>UV detector wearing out</li> <li>Opaque oxides building up on UV source Filter</li> <li>UV lamp aging</li> </ul>



## 9. THEORY OF OPERATION

### 9.1. The UV Light Path

The UV light path of the M100EH is similar to that of the M100E (see Section 10.2 of the M100E Manual). The main differences between the M100EH and the M100E are:

- The location of the reference detector (See Section 9.1.1 of this addendum).
- The methods used to reject for certain measurement interferences is different (see Section 9.1.2 of this addendum).

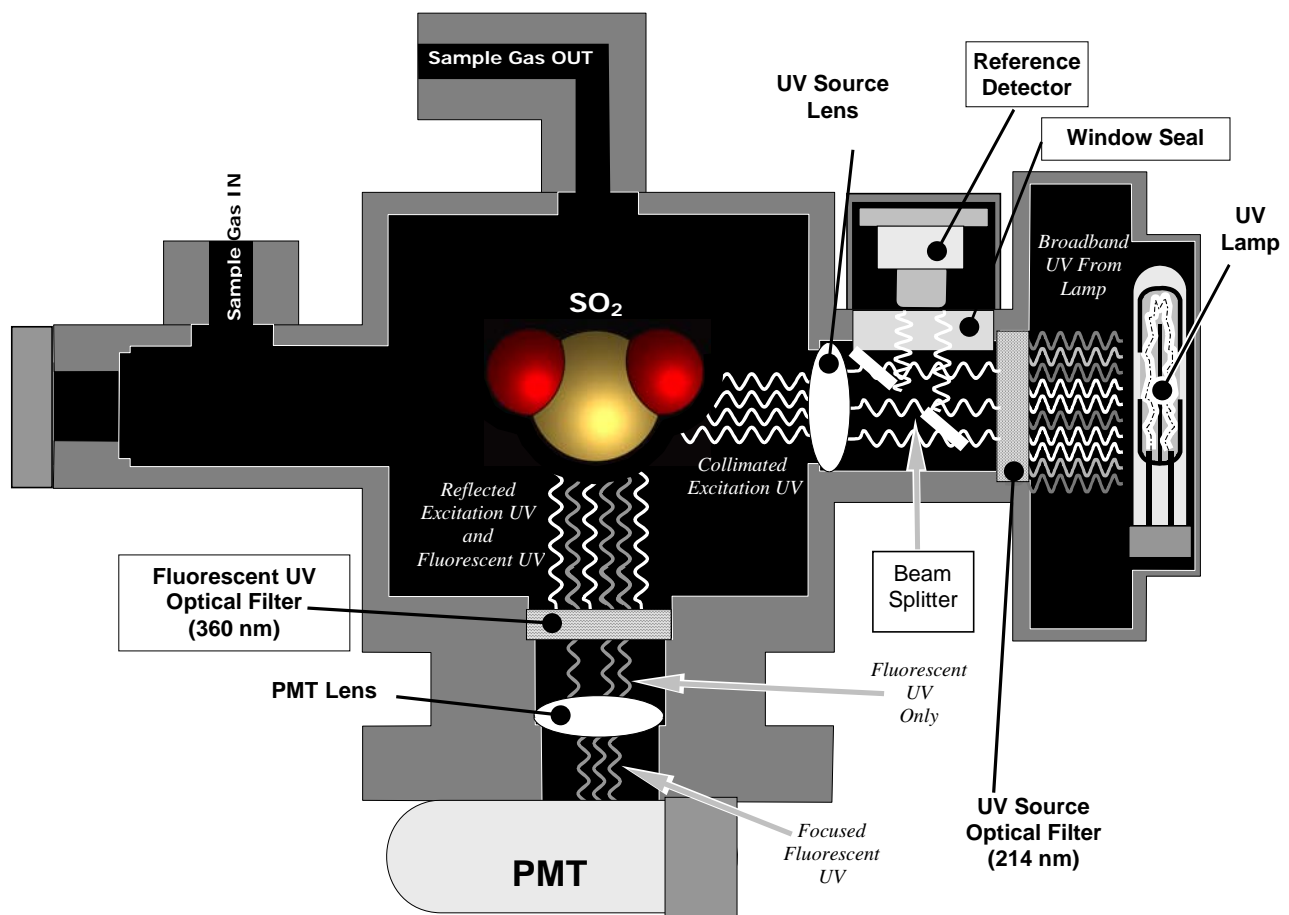

Figure 9-1: UV Light Path

### 9.1.1. The Reference Detector

A vacuum diode UV detector that converts UV light to a DC current is used to measure the intensity of the excitation UV source lamp. The location of the M100EH reference detector differs from that of the M100E.

- On the M100E this detector is located directly across the reaction cell from the lamp where it can measure the output of the lamp directly. Because the M100E is designed to measure relatively low concentrations of SO<sub>2</sub>, enough of the lamp's 214 nm source light makes it through the reaction cell to get a reliable reading.
- On the M100EH the detector is located between the UV lamp and the reaction cell and to the side. A beam splitter reflects a portion of the lamp output 90 degrees, through a window and onto the detector. This arrangement is required because nearly all of 214 nm UV source light entering the reaction cell is absorbed by the higher concentrations of SO<sub>2</sub> typically measured by the M100EH.

A window transparent to UV light provides an air-proof seal that prevents ambient gas from contaminating the sample chamber.

### 9.1.2. Direct Measurement Interferences

The most common source of interference when measuring SO<sub>2</sub> is from other gases that fluoresce in a similar fashion to SO<sub>2</sub> when exposed to UV Light. The most significant of these are:

- A class of hydrocarbons called poly-nuclear aromatics (PNA) of which xylene and naphthalene are two prominent examples.
- Nitric oxide (NO), which fluoresces in the a spectral range near to SO<sub>2</sub>. For critical applications where high levels of NO are expected an optional 360 nm optical filter is available that improves the rejection of NO (contact customer service for more information).

The methods by which the Model 100EH rejects interference for these substances differs from the M100E as follows.

- Since the typical application for which the M100EH rarely includes the presences of hydrocarbons or PNA's, no hydrocarbon scrubber (kicker) is included in the M100EH's base configuration. An optional scrubber (see Section 5.4 of this addendum is available).
- On the other hand the typical M100EH application often includes much higher concentrations of Nitric Oxide (NO), which fluoresces in a spectral range near that of SO<sub>2</sub>. Therefore a 360 nm filter replaces the 330nm UV filter located between the PMT and the reaction cell in order to more efficiently reject for interference due to the higher concentrations of NO.

## 9.2. Pneumatic Operation

### 9.2.1. Sample Gas Flow

The Flow of gas through the M100EH UV Fluorescence SO<sub>2</sub> Analyzer is created by a small external pump that pulls air through the instrument. The M100EH has no kicker to scrub hydrocarbons from the sample stream. Typical applications for the M100EH do not have hydrocarbons in the sample stream.

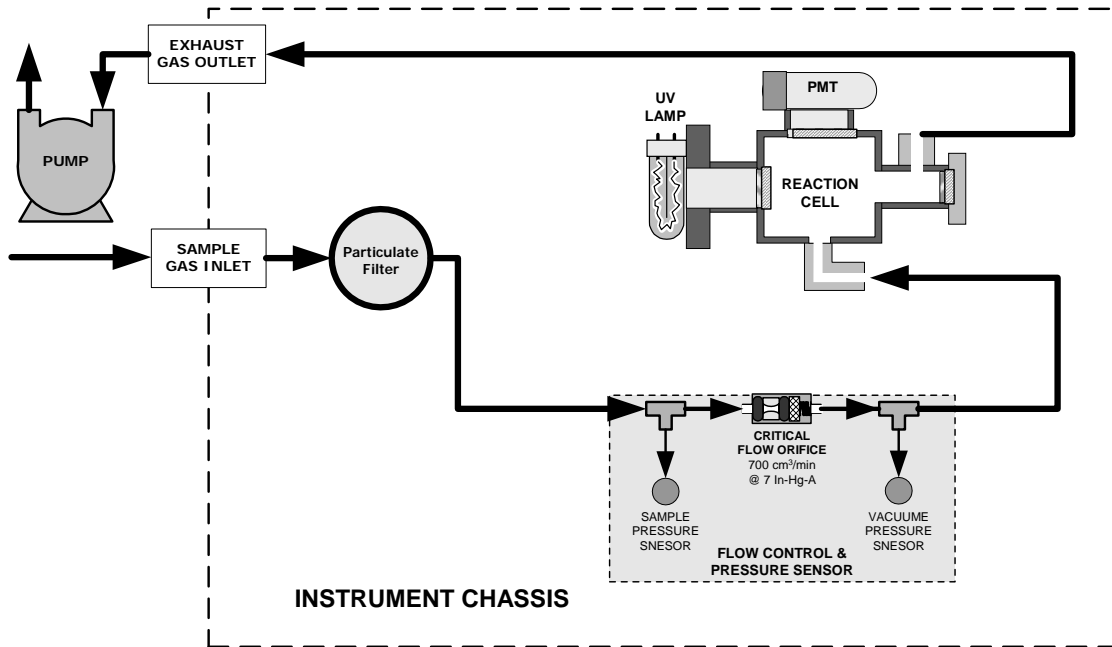

Figure 9-2: Pneumatic Diagram of the M100EH – Base Configuration

## 9.2.2. Pneumatic Sensors

The M100EH uses two pneumatic sensors to verify gas flow. These sensors are located on a printed circuit assembly, called the pneumatic pressure/flow sensor board. This PCA is attached to a manifold containing the critical flow orifice that sets the instrument flow rate.

### 9.2.2.1. Sample Pressure Sensor

An absolute pressure transducer plumbed to the input of the analyzer's sample chamber is used to measure the pressure of the sample gas before it passes through the critical flow orifice. This is used to validate the critical flow condition (2:1 pressure ratio) through the instrument's critical flow orifice.

The actual sample gas pressure measurement is viewable through the analyzer's front panel display as the test function **PRES**

### 9.2.2.2. Vacuum Pressure Sensor

An absolute pressure transducer measures the pressure on the vacuum side of the critical flow orifice and is used to measure the sample gas pressure in the reaction cell. If the vacuum pressure is not in the correct range, a warning will be displayed by the software. Also, if the temperature/pressure compensation (TPC) feature is turned on, the output of this sensor is also used to supply pressure data for that calculation.

The actual pressure of the gas downstream from the critical flow orifice (including the gas inside the reaction cell) viewable through the analyzer's front panel display as the test function **VAC**

### 9.2.2.3. Sample Flow Calculation

Unlike the M100E, which uses a thermal-mass flow sensor to directly measure the gas flow through the instrument, the M100EH calculates the gas as follows.

- The ratio of the two pressures is measured and used to validate critical flow. If the ratio is not correct (< 2:1) the **SAMPLE FLOW WARN** message is activated. Also, the value of the **SAMP FL** test function is set to **XXXX**.

If the pressure ratio between the two sensors is valid ( $\geq 2:1$ ), the instrument calculates the flow based on sample gas pressure level (**PRES**) and is viewable via the front panel as the **SAMP FL** test function.

### 9.3. Electronic Operation

The following figures replace Figures 10-10 & 10-19 of the M100E Manual (P/N 04515). There is no IZS option, a vacuum pressure sensor replaces the M100E's thermal-mass flow sensor and provision is made for the two span point valve option

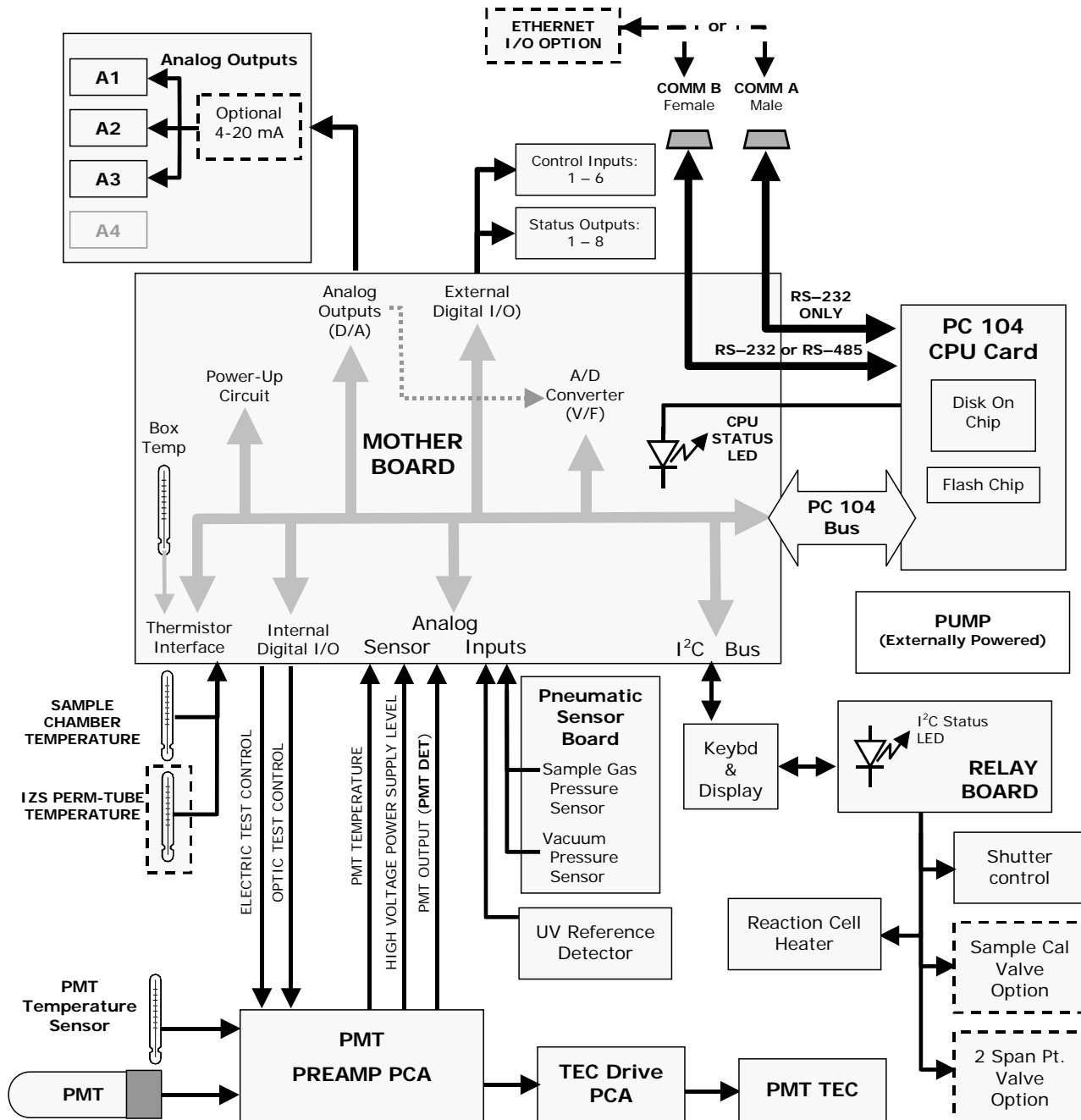

Figure 9-3: M100EH Electronic Block Diagram

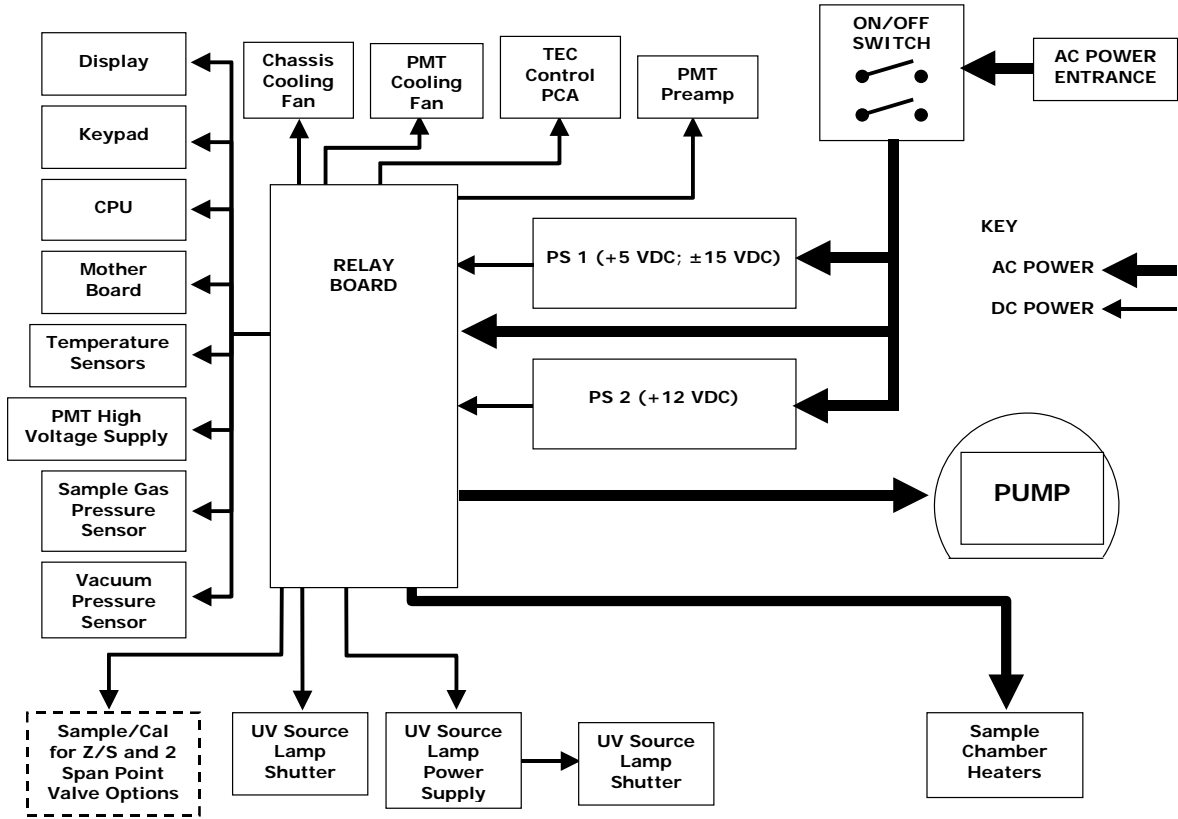

Figure 9-4: M100EH Power Distribution Block Diagram

USER NOTES:

## 10. TROUBLESHOOTING & REPAIR

For the most part the information contained in Chapter 11 of the M100E Manual (P/N 04515) is also applicable to the M100EH. There are a few exceptions however.

### 10.1.1. Fault Diagnosis with Warning Messages

Table 10-1: Warning Messages - Indicated Failures

WARNING MESSAGE	FAULT CONDITION	POSSIBLE CAUSES
<b>VACUUM PRESS WARN</b>	Gas pressure inside the reaction cell outside of warning limits.	If sample pressure is > 10 in-Hg: <ul style="list-style-type: none"> <li>○ Pneumatic Leak</li> <li>○ Bad Pump → Rebuild Pump</li> <li>○ Failed pressure sensor/circuitry</li> </ul>

### 10.1.2. Fault Diagnosis with Test Functions

Table 10-2: Test Functions - Possible Causes for Out-Of-Range Values

TEST FUNCTION	NOMINAL VALUE(S)	POSSIBLE CAUSE(S)
<b>VAC</b>	<9.1 IN-HG-A	Incorrect sample gas pressure could be due to: pneumatic leak; malfunctioning valve; malfunctioning pump; clogged flow orifices; sample inlet overpressure; faulty pressure sensor

## 10.2. Subsystem Checkout

### 10.2.1. Pneumatic Sensor Assembly

The pneumatic sensor assembly of the M100EH differs from that of the M100E in that there is no flow sensor. Instead the assembly includes two pressure sensors located on either side of a critical flow orifice. The M100EH software infers the gas flow rate by mathematically comparing the two pressure readings.

If you suspect that one of the two pressure sensors is failing:

1. Cap the sample inlet.
2. After a few seconds, check the **VAC** and **PRES** test functions and verify that:
  - The **VAC** value matches the **PRES** value to within 1 In-Hg-A, and;
  - Both are less than 10 in-Hg-A (i.e. under vacuum).
3. Uncap the sample inlet and unplug the pump.
4. After a few minutes, the value **VAC** and **PRES** should match within 1 In-Hg-A, and read atmospheric pressure.
  - If the two sensors do not match or are significantly different from ambient atmospheric pressure, call Teledyne Instruments customer service.

## 10.3. Repair Procedures

### 10.3.1. Repairing the Sample Gas Flow Control Assembly

The Critical Flow Orifice is part of the pressure sensor and flow control assembly. The jewel orifice is protected by a sintered filter, so it is unusual for the orifice to need replacing, but it is possible for the sintered filter and o-rings to need replacing. See the Spare Parts list in Appendix B for part numbers and kits.

To replace the filter and/or orifice

1. Turn off Power to the analyzer.
2. Locate the pressure sensor / flow control assembly.
3. Disconnect the signal cable and pneumatic fittings.
4. Remove the assembly from the optical bench by removing the 2 screws at each end of the assembly.
5. The inlet end of the assembly is located at the end with the straight pneumatic fitting. Remove the fitting and the components as shown in the exploded view.
6. Replace the o-rings (p/n:OR01) and the sintered filter (p/n:FL01).
7. if you are replacing the Critical Flow Orifice itself (p/n:00094100), make sure that the side with the colored window (usually RED) is facing upstream to the flow gas flow.
8. Re-assemble in reverse order. See the Spares List in Appendix B for part numbers.
9. After re-connecting the power and pneumatic lines, flow check the instrument as described in the Section 11.5.2 of the M100E Operator's Manual.

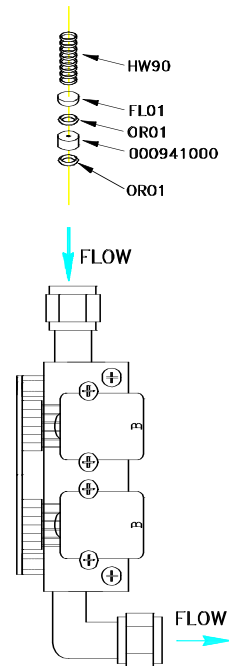

Figure 10-1: Flow Control Assembly

### 10.3.2. Sensor Module Repair & Cleaning

**NOTE:**

After any repair or service has been performed on the sensor module, the M100EH should be allowed to warm up for 60 minutes.

Always perform a leak check (See Section 11.5.1) and calibrate the analyzer (see Chapter 7) before placing it back in service.

The most significant difference between the M100E sensor module and the M100EH sensor module is the location of the reference detector. Therefore most of the procedures described in Section 11.6.3 apply to the M100EH as well.

Exceptions are noted below:

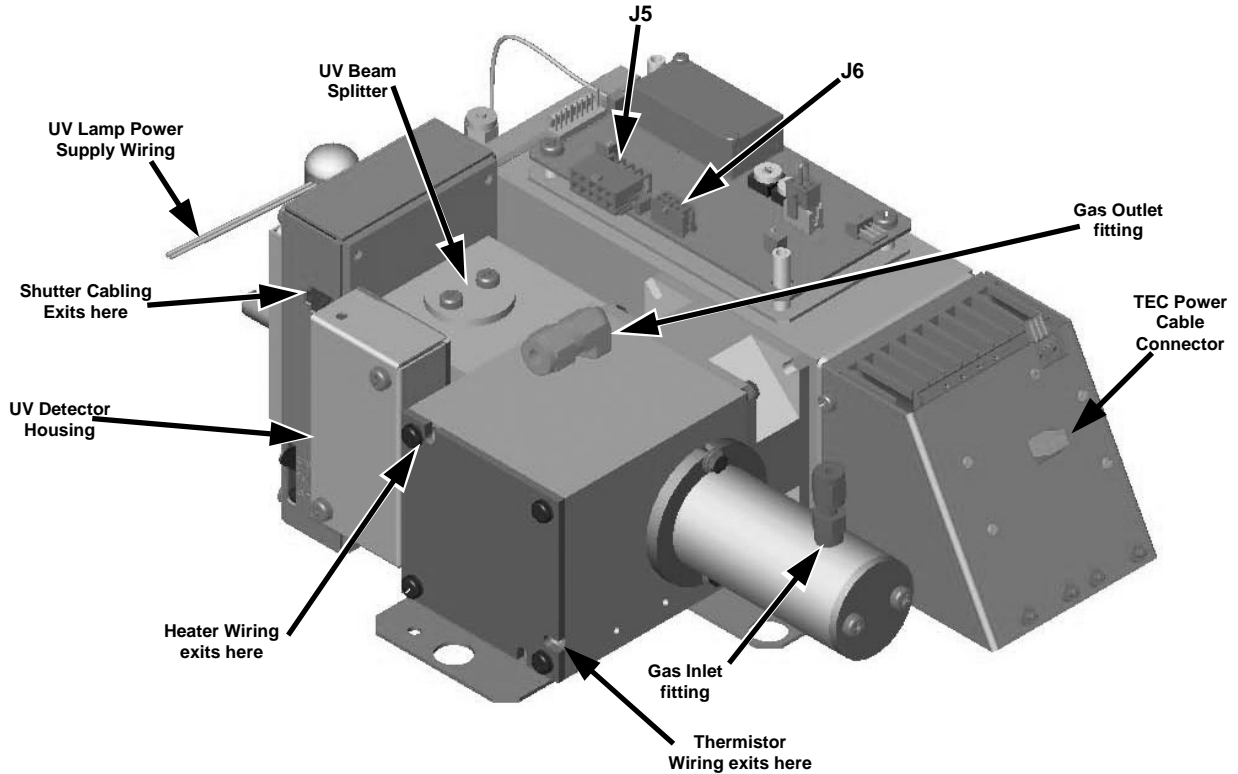

Figure 10-2: Sensor Module Wiring and Pneumatic Fittings

### 10.3.2.1. Adjusting the UV Lamp (*Peaking the Lamp*)

There are three ways in which ambient conditions can effect the UV Lamp output and therefore the accuracy of the SO<sub>2</sub> concentration measurement. These are:

**Line Voltage Change:** UV lamp energy is directly proportional to the line voltage. This can be avoided by installing adequate AC Line conditioning equipment such as a UPS/surge suppressor.

**Lamp Aging** - Over a period of months, the UV energy will show a downward trend, usually 30% in the first 90 days, and then a slower rate, until the end of useful life of the lamp. Periodically running the UV lamp calibration routine (see Section 6.9.7) will compensate for this until the lamp output becomes too low to function at all.

**Lamp Positioning** – The UV output level of the lamp is not even across the entire length of the lamp. Some portions of the lamp shine slightly more brightly than others. At the factory the position of the UV lamp is adjusted to optimize the amount of UV light shining through the UV filter/lens and into the reaction cell. Changes to the physical alignment of the lamp can affect the analyzers ability to accurately measure SO<sub>2</sub>.

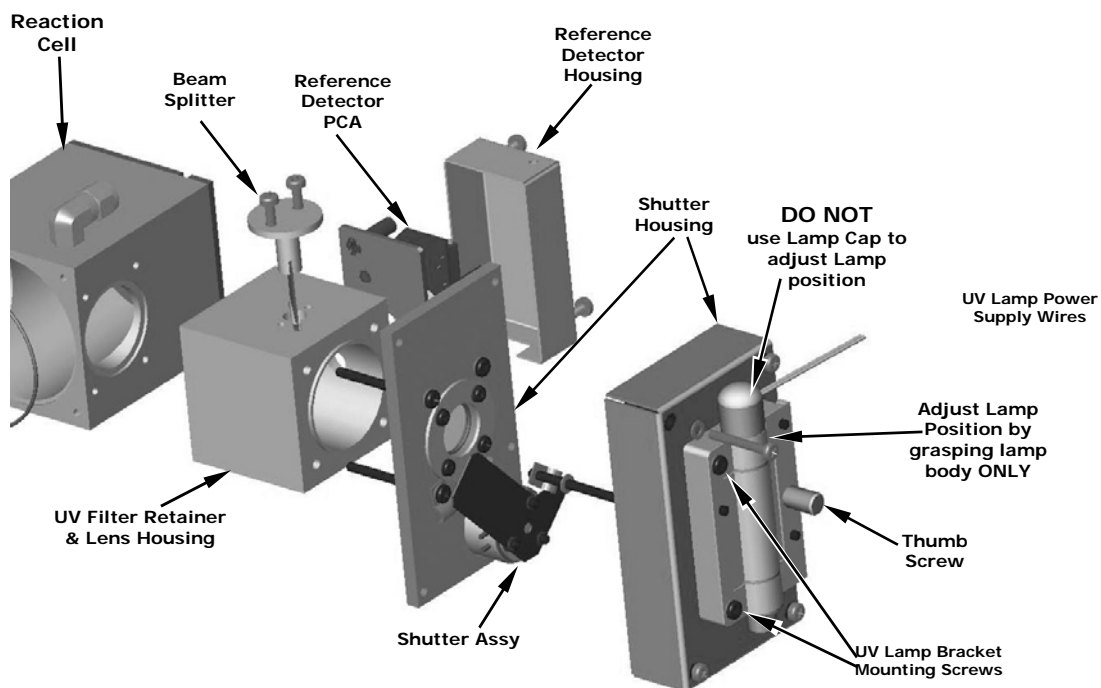

Figure 10-3: Shutter Assembly - Exploded View



**CAUTION:**

**ALWAYS wear UV-Protective, Safety Glasses when working with the UV Lamp Assembly**

1. Set the analyzer display to show the signal I/O function, **UVLAMP\_SIGNAL** (see Section 11.1.3). **UVLAMP\_SIGNAL** is function 33.
2. Slightly loosen the large brass thumbscrew located on the shutter housing (see Figure 10-3) so that the lamp can be moved.
3. While watching the **UVLAMP\_SIGNAL** reading, slowly rotate the lamp or move it back and forth vertically until the **UVLAMP\_SIGNAL** reading is at its maximum.

- **DO NOT** grasp the UV lamp by its cap when changing its position (see Figure 10-3). Always grasp the main body of the lamp.
4. Compare the **UVLAMP\_SIGNAL** reading to the information in Table 10-3 and follow the instructions there.

**Table 10-3: Example of HVPS Power Supply Outputs**

<b>UVLAMP_SIGNAL</b>	<b>ACTION TO BE TAKEN</b>
3500mV±200mV.	No Action Required
> 4900mV at any time.	Adjust the UV reference detector potentiometer (see Figure 10-4) until <b>UVLAMP_SIGNAL</b> reads approximately 3600mV before continuing to adjust the lamp position.
>4500mV or < 1000mV	Adjust the UV reference detector potentiometer (see Figure 10-4) until <b>UVLAMP_SIGNAL</b> reads as close to 3500mV as possible.
< 600mV	Replace the lamp.

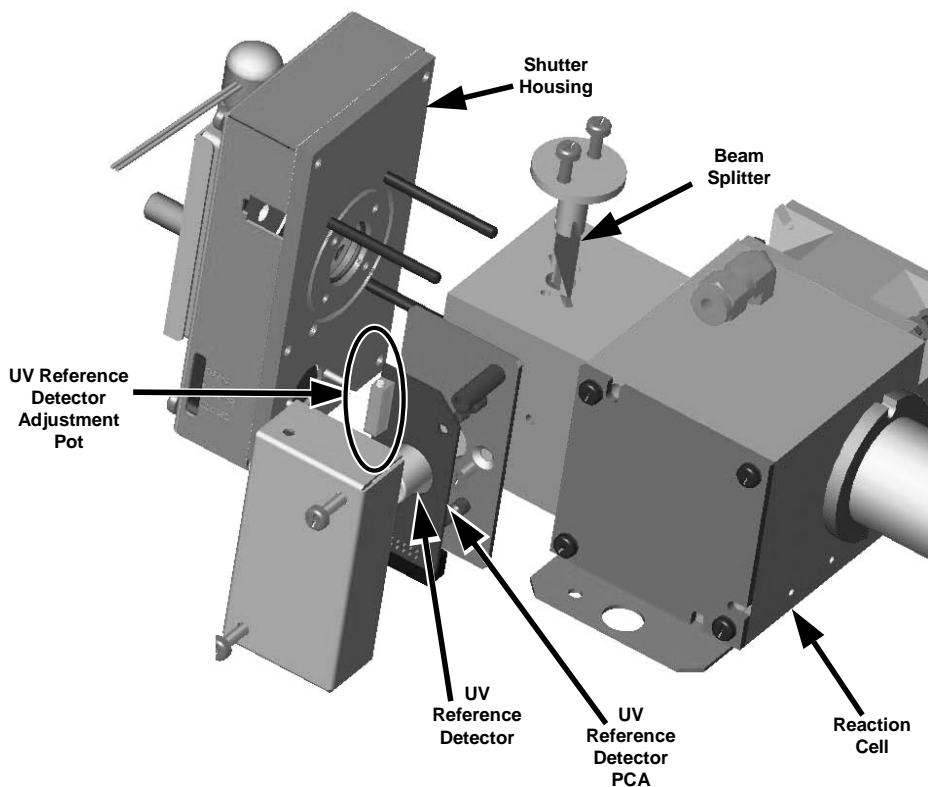

**Figure 10-4: Location of UV Reference Detector Potentiometer**

5. Finger tighten the thumbscrew.

**NOTE:**  
**DO NOT over-tighten the thumbscrew.**

### 10.3.2.2. PMT Hardware Calibration (**FACTORY CAL**)

The sensor module hardware calibration adjusts the slope of the PMT output when the instrument's slope and offset values are outside of the acceptable range and all other more obvious causes for this problem have been eliminated.

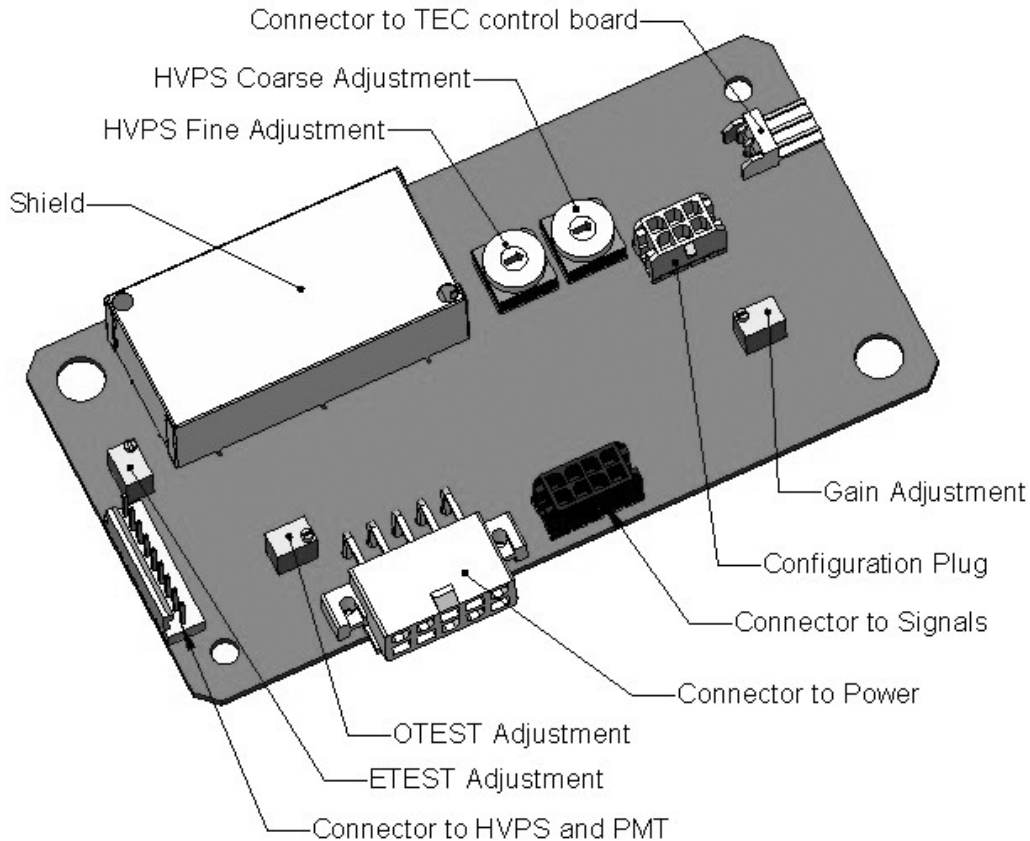

**Figure 10-5: Pre-Amplifier Board Layout**

1. Set the instrument reporting range type to **SNGL** (see Section 6.7.4 of the M100E Manual)
2. Perform a zero-point calibration using zero air (see Chapter 7 of the M100E Manual).
3. Let the instrument stabilize by allowing it to run for one hour.
4. Adjust the UV Lamp. (See Section 10.3.2.1 of this addendum)
5. Perform a **LAMP CALIBRATION** procedure (see Section 6.9.7 of the M100E Manual).
6. Locate the Preamp board (see Figure 3-4 of this addendum).
7. Locate the Following Components On the Preamp board (see Figure 10-5 of this addendum):
  - HVPS coarse adjustment switch (Range 0-9, then A-F)
  - HVPS fine adjustment switch (Range 0-9, then A-F)
  - Gain adjustment potentiometer (Full scale is 10 to 12 turns).

8. Set the HVPS coarse adjustment to its minimum setting (0).
9. Set the HVPS fine adjustment switch to its maximum setting (F).
10. Turn the gain adjustment potentiometer clockwise to its maximum setting.
11. Set the front panel display to show **STABIL** (see Section 6.2.1 of the M100E Manual)
12. Feed span gas into the analyzer.
13. Wait until the **STABIL** value is below 0.5 ppm,

**NOTE**

Use a span gas equal to 80% of the reporting range.

Example: for a reporting range of 200 ppm, use a span gas of 160 ppm.

14. Scroll to the **OFFSET** function and record the value.
15. Scroll to the **NORM PMT** value.

**NOTE**

Do not overload the PMT by accidentally setting both adjustment switches to their maximum setting. This can cause permanent damage to the PMT.

16. Determine the target **NORM PMT** value according to the following formulas.
  - If the reporting range is set for  $\leq 500$  ppm (the instrument will be using the 500 ppm physical range):  
Target **NORM PMT** = (8 x span gas concentration) + **OFFSET**
  - If the reporting range is set for  $\geq 2,001$  ppb (the instrument will be using the 5,000 ppm physical range):  
Target **NORM PMT** = (0.8 x span gas concentration) + **OFFSET**

**EXAMPLE:** If the **OFFSET** is 33 mV, the Reporting Range is 1000 ppm, the span gas should be 800 ppm SO<sub>2</sub> and the calculation would be:

$$\begin{aligned}\text{Target } \mathbf{NORM PMT} &= (0.8 \times 800) + 33 \text{ mV} \\ \text{Target } \mathbf{NORM PMT} &= 640 + 33 \text{ mV} \\ \text{Target } \mathbf{NORM PMT} &= 673 \text{ mV}\end{aligned}$$

17. Set the HVPS coarse adjustment switch to the lowest setting that will give you more than the target NORM PMT signal from Step 16.
  - The coarse adjustment typically increments the **NORM PMT** signal in 100-300 mV steps.
18. Adjust the HVPS fine adjustment such that the **NORM PMT** value is at or just above the target NORM PMT signal from Step 16.
19. Continue adjusting the both the coarse and fine switches until **NORM PMT** is as close to (but not below) the target NORM PMT value from Step 16.
20. Adjust gain adjustment potentiometer until the **NORM PMT** value is  $\pm 10$  mV of the target level from Step 16.
21. Perform span calibration (see Chapter 7 of the M100E Manual)
22. Scroll to the **SLOPE** function and record the value.
23. If the value of the **SLOPE** is between 0.900 and 1.100 the PMT Hardware calibration is complete.
24. If the value of the **SLOPE** is less than 0.900 or greater than 1.100:
  1. Multiply the slope value from step 22 by the norm PMT value from step 19.
  2. Repeat steps 17 through 24 using this new value for **NORM PMT**.

## 10.4. Technical Assistance

If this manual and its trouble-shooting / repair sections do not solve your problems, technical assistance may be obtained from Teledyne Instruments, Customer Service, 9480 Carroll Park Drive, San Diego, CA 92121. Phone: +1 858 657 9800 or 1-800 324 5190. Fax: +1 858 657 9816. Email: [api-customerservice@teledyne.com](mailto:api-customerservice@teledyne.com).

Before you contact customer service, fill out the problem report form in Appendix C, which is also available online for electronic submission at <http://www.teledyne-api.com/forms/index.asp>.

---

## USER NOTES:

## **APPENDIX A - Version Specific Software Documentation**

**APPENDIX A-1: Model 100EH Software Menu Trees**

**APPENDIX A-2: Model 100EH Setup Variables Available Via Serial I/O**

**APPENDIX A-3: Model 100EH Warnings and Test Measurements Via Serial I/O**

**APPENDIX A-4: Model 100EH Signal I/O Definitions**

**APPENDIX A-5: Model 100EH iDAS Functions**

**APPENDIX A-6: Model 100EH Terminal Command Designators**

APPENDIX A-1: M100EH Software Menu Trees, Revision C.0

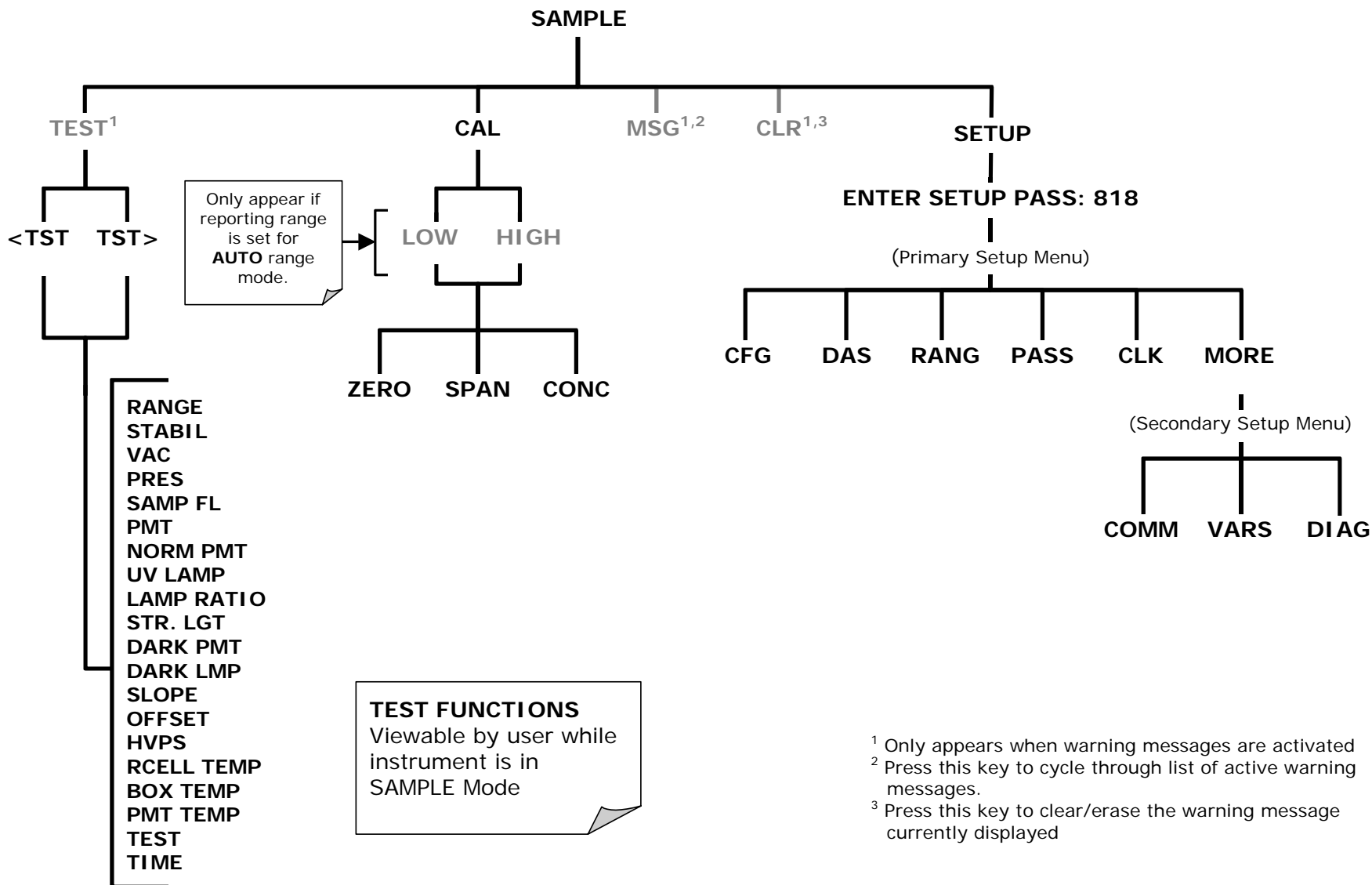

¹ Only appears when warning messages are activated  
 ² Press this key to cycle through list of active warning messages.  
 ³ Press this key to clear/erase the warning message currently displayed

Figure A-1: Basic Sample Display Menu

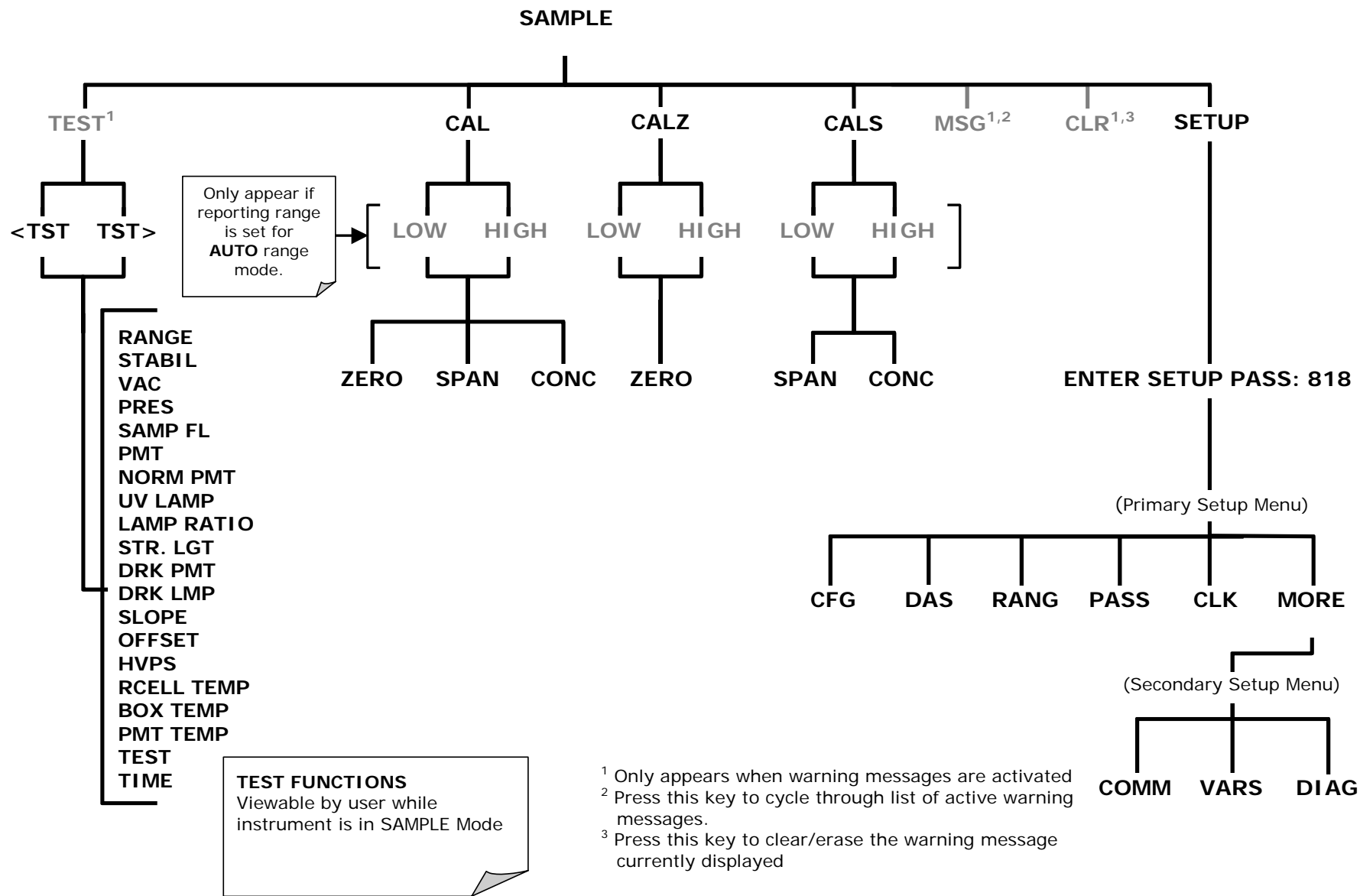

Only appear if reporting range is set for AUTO range mode.

**TEST FUNCTIONS**  
Viewable by user while instrument is in SAMPLE Mode

- <sup>1</sup> Only appears when warning messages are activated
- <sup>2</sup> Press this key to cycle through list of active warning messages.
- <sup>3</sup> Press this key to clear/erase the warning message currently displayed

Figure A-2: Sample Display Menu - Z/S Valve Option installed

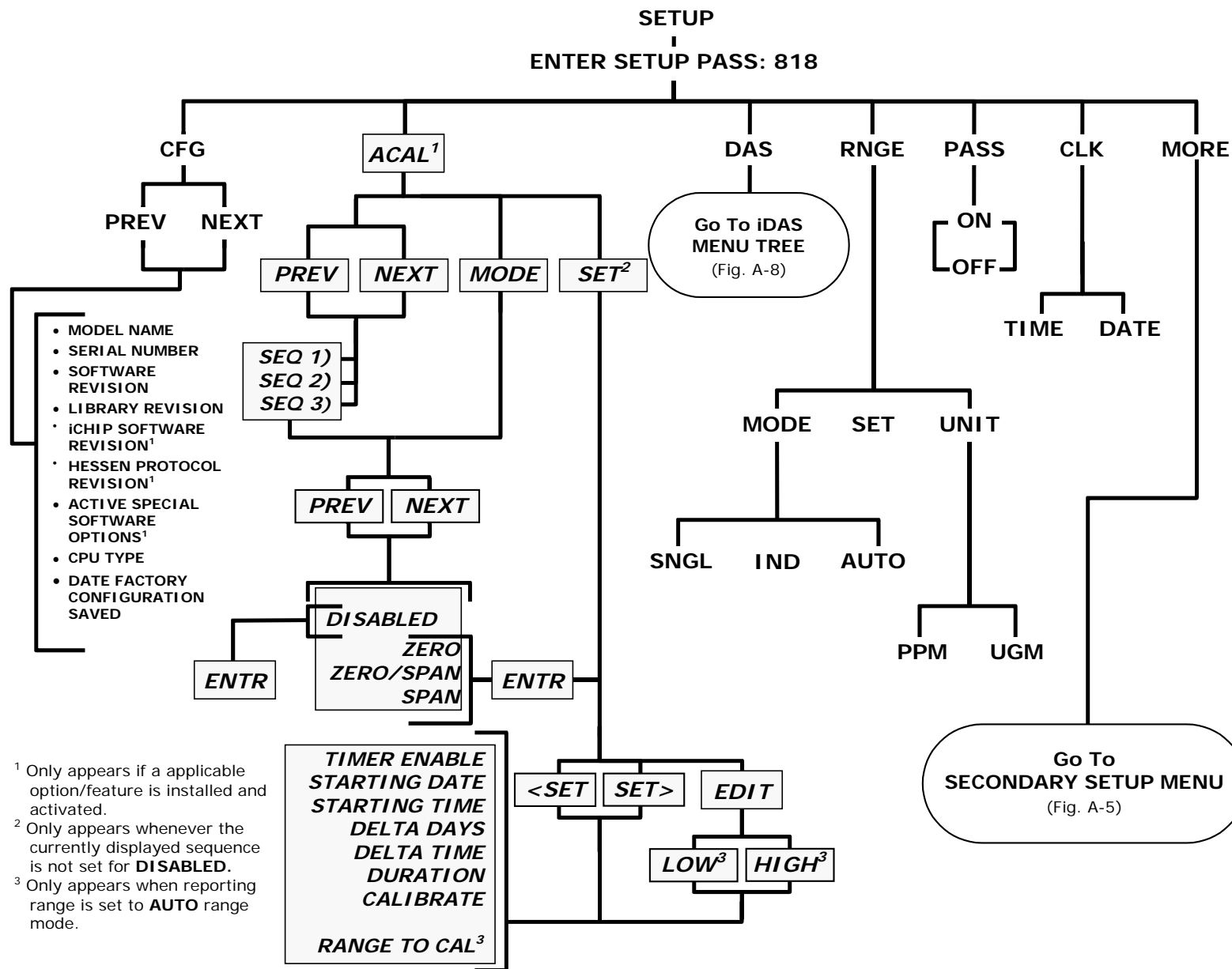

Figure A-3: Primary Setup Menu (Except iDAS)

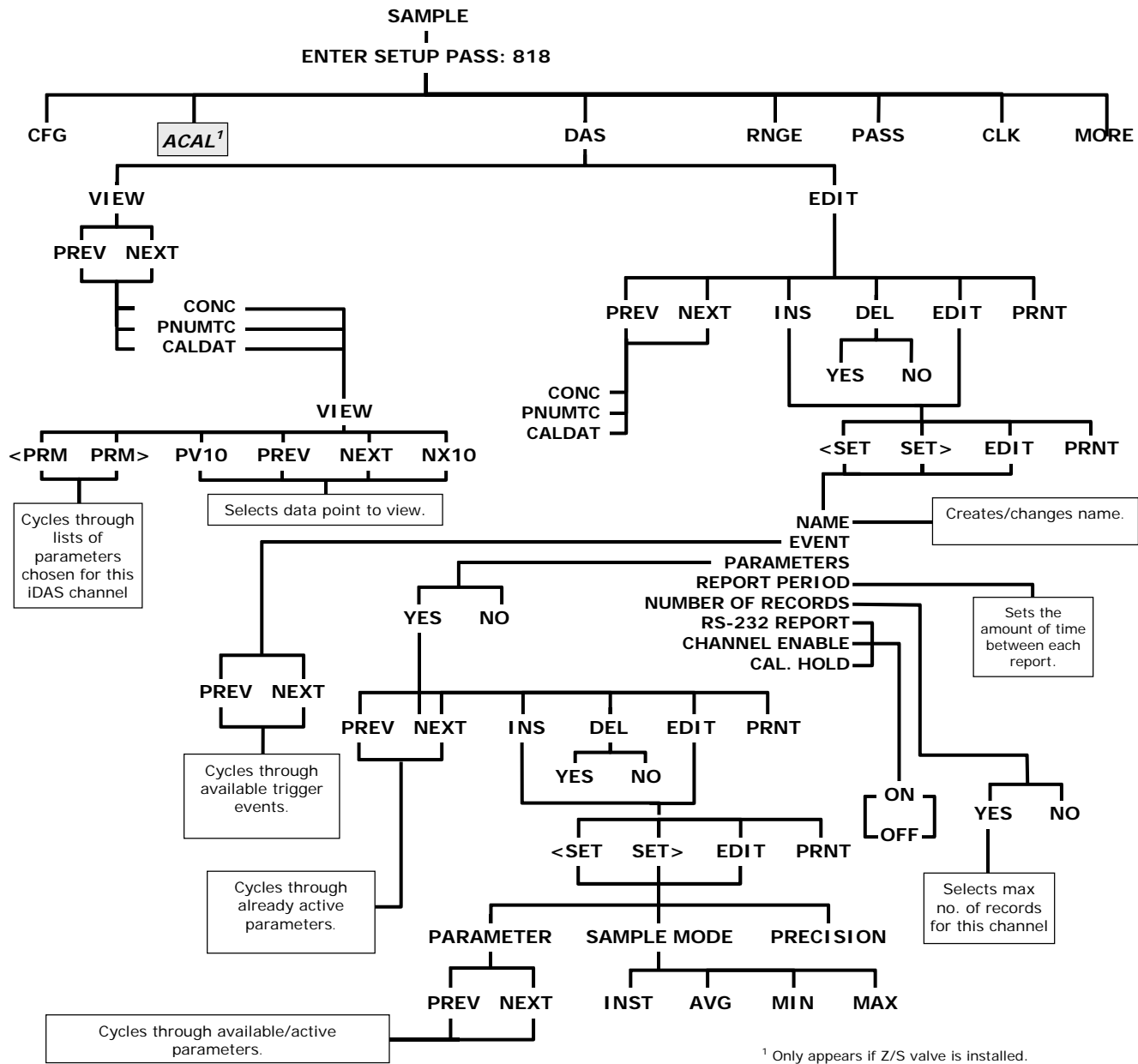

Figure A-4: Primary Setup Menu (iDAS)

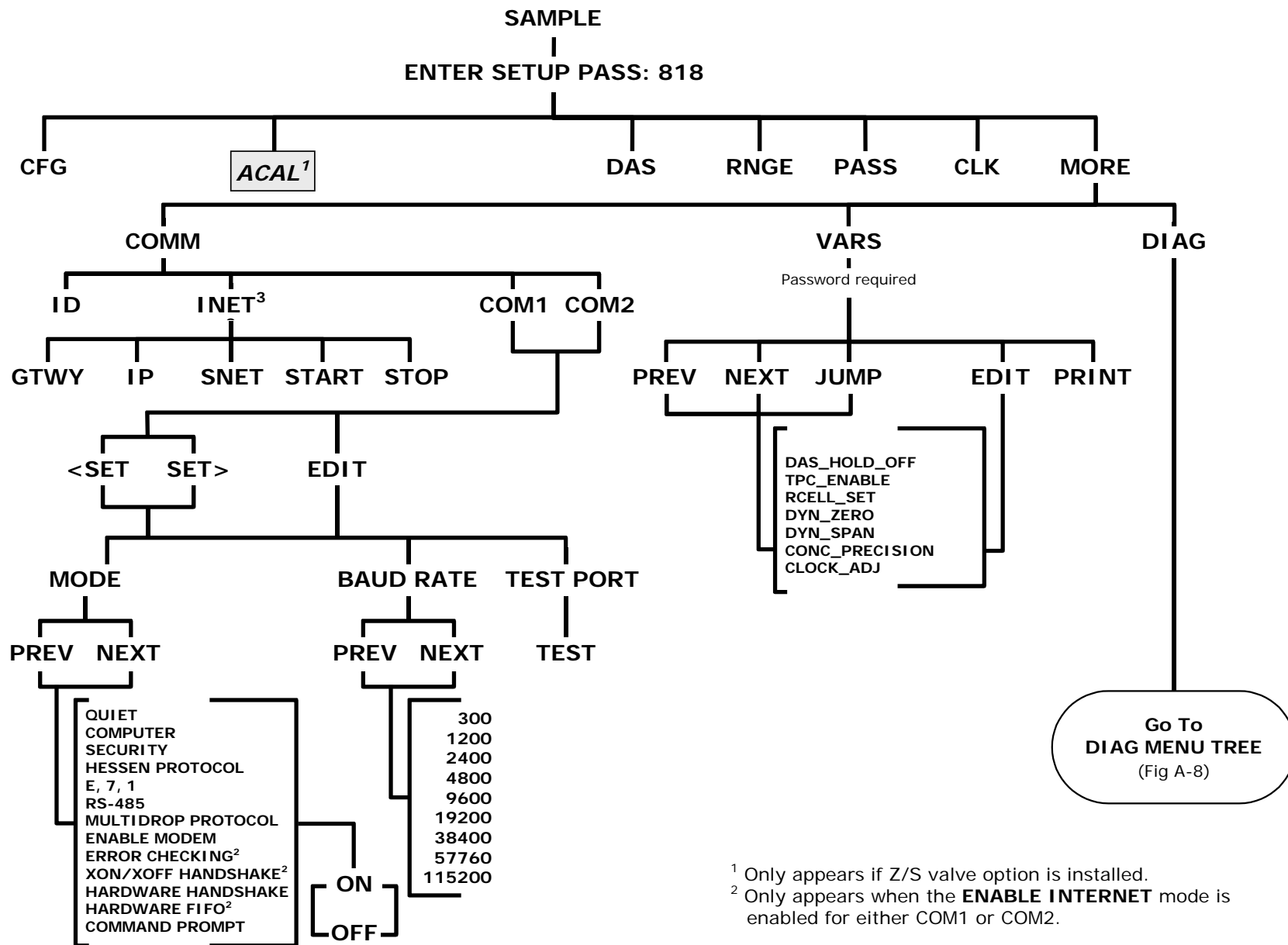
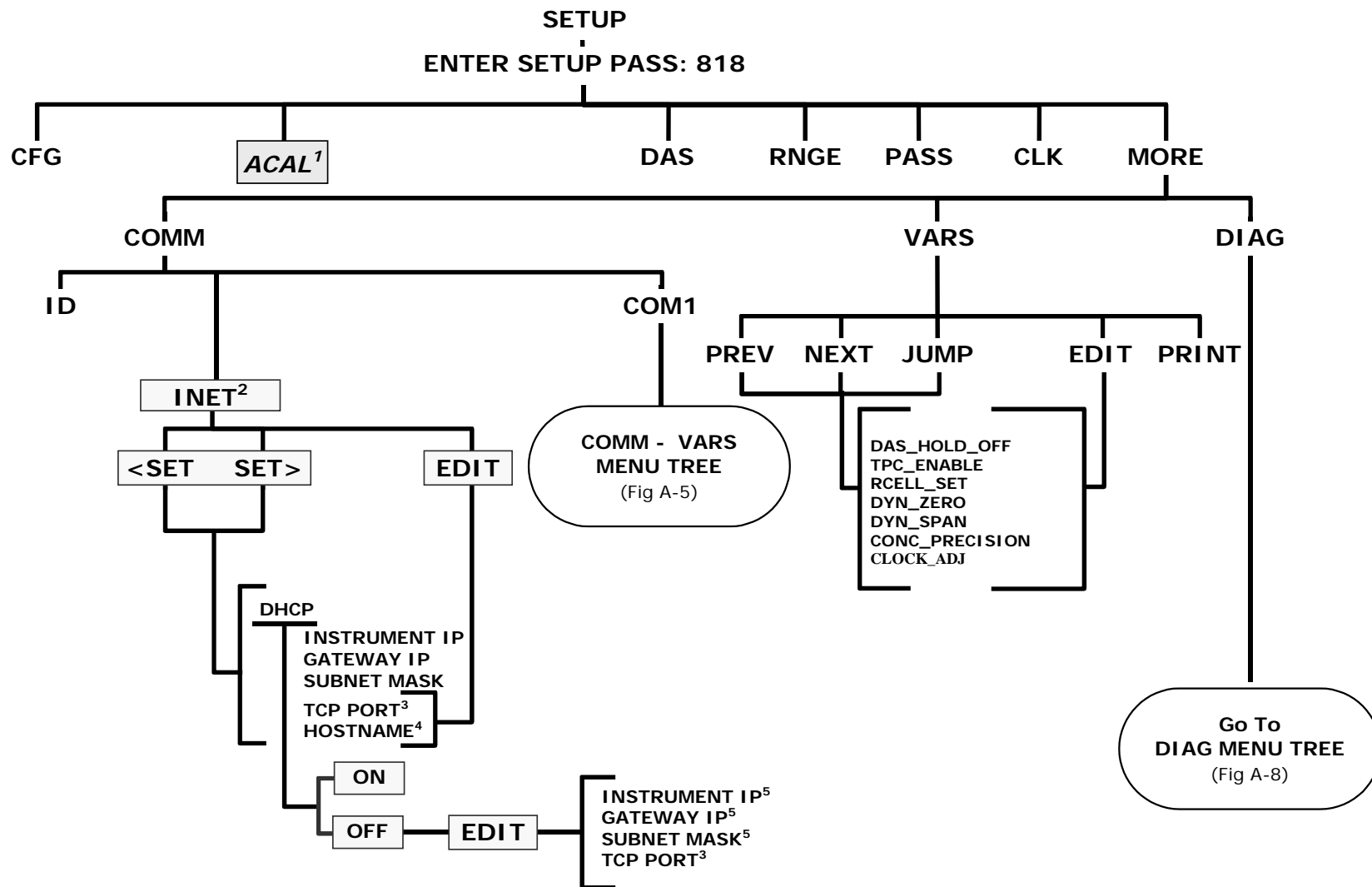

Figure A-5: Secondary Setup Menu (COMM & VARS)



<sup>1</sup> Only appears if a valve option is installed.  
<sup>2</sup> Only appears when the Ethernet card (option 63) is installed.  
<sup>3</sup> Although **TCP PORT** is editable regardless of the **DHCP** state, do not change the setting for this property unless instructed to by Teledyne Instruments Customer Service personnel.  
<sup>4</sup> **HOST NAME** is only editable when **DHCP** is **ON**.  
<sup>5</sup> **INSTRUMENT IP**, **GATEWAY IP** & **SUBNET MASK** are only editable when **DHCP** is **OFF**.

Figure A-6: Secondary Setup Menu (COMM Menu with Ethernet Card)

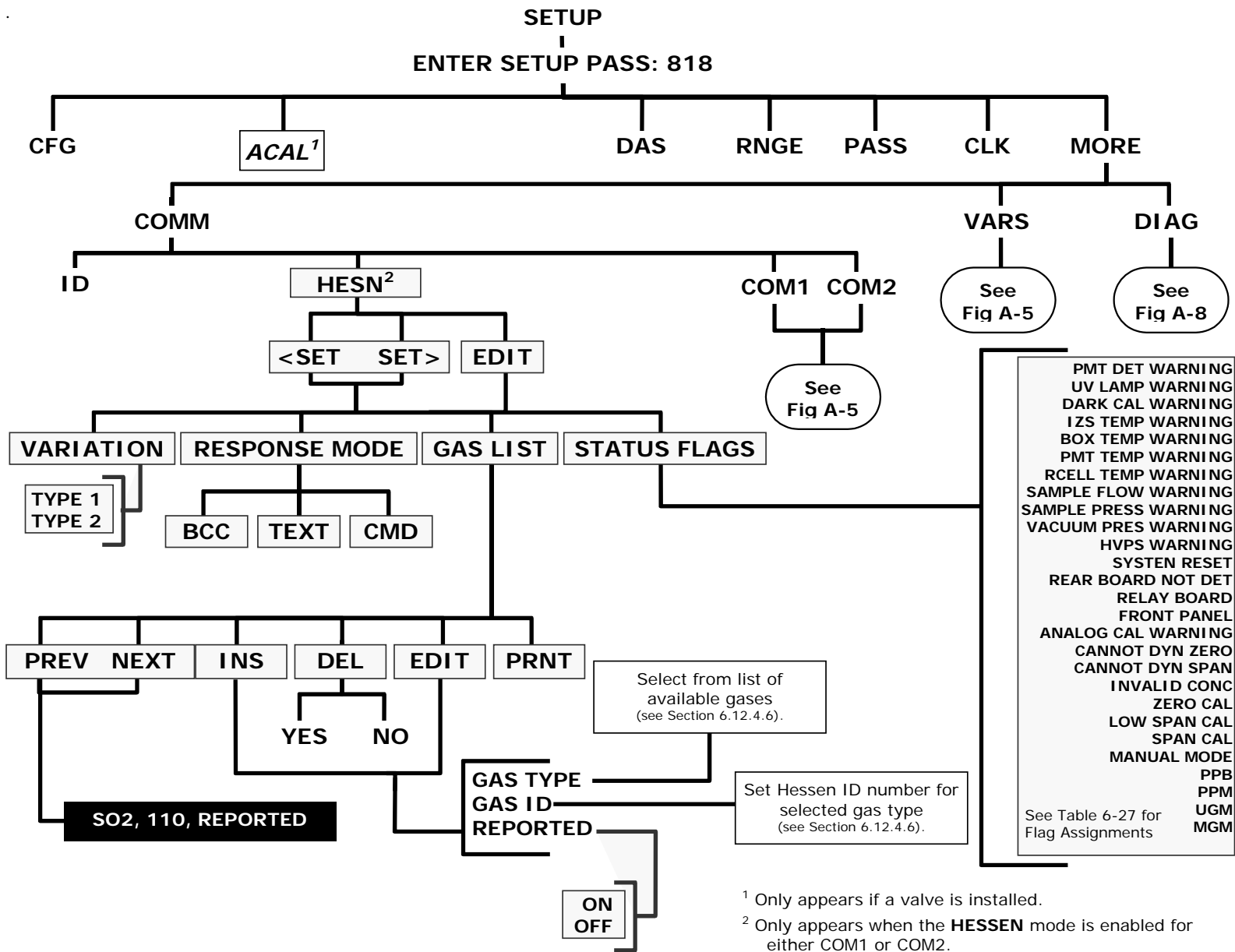

Figure A-7: Secondary Setup Menu - HESSEN Submenu

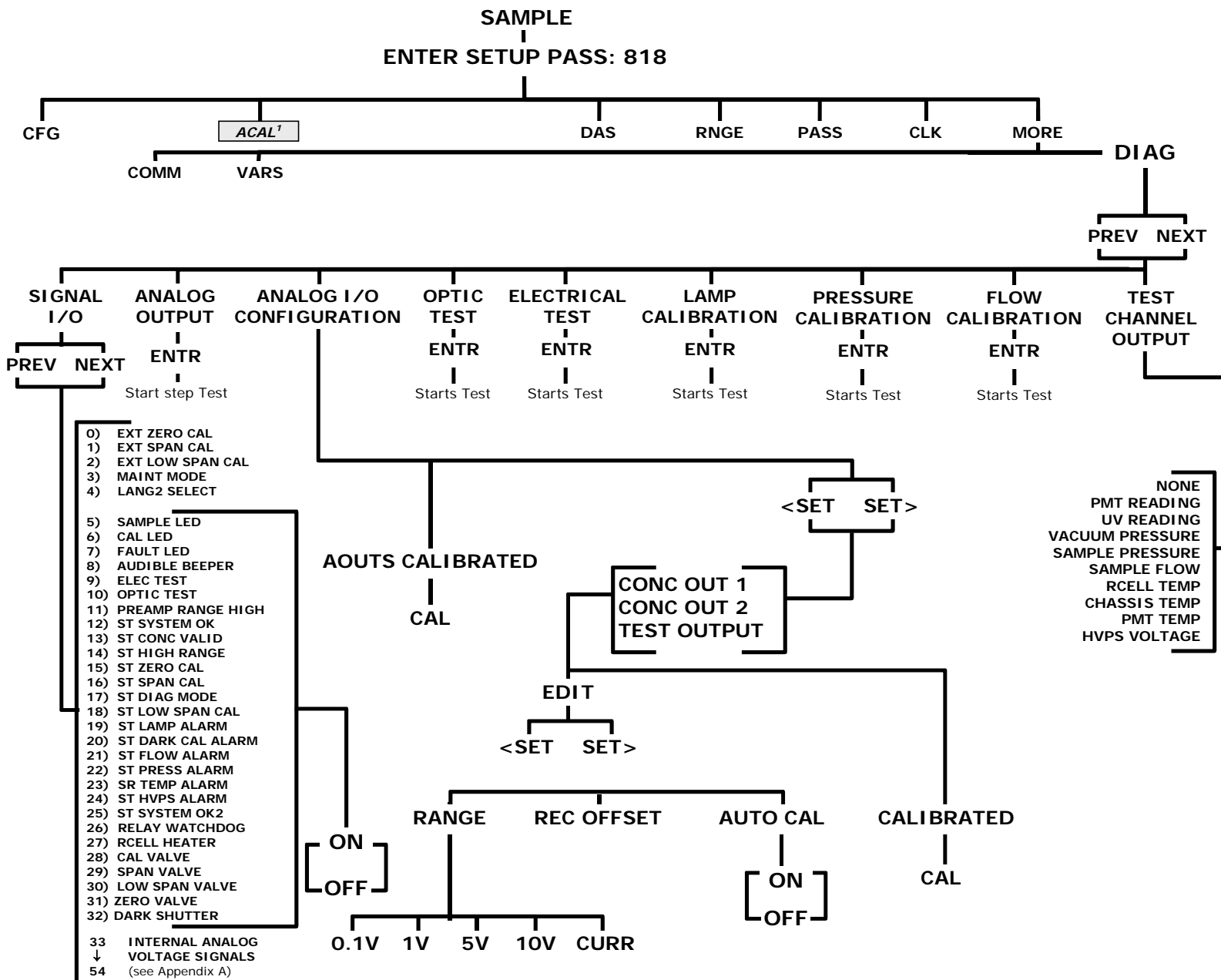

Figure A-8: Secondary Setup Menu (DIAG)

APPENDIX A-2: Setup Variables For Serial I/O, Revision C.0

Table A-1: M100EH Setup Variables, Revision C.0

SETUP VARIABLE	NUMERIC UNITS	DEFAULT VALUE	VALUE RANGE	DESCRIPTION
DAS_HOLD_OFF	Minutes	15	0.5–20	Duration of DAS hold off period.
TPC_ENABLE	—	ON	OFF, ON	ON enables temperature and pressure compensation; OFF disables it.
RCELL_SET	°C	50 Warnings: 45–55	30–70	Reaction cell temperature set point and warning limits.
DYN_ZERO	—	OFF	OFF, ON	ON enables contact closure dynamic zero; OFF disables it.
DYN_SPAN	—	OFF	OFF, ON	ON enables contact closure dynamic span; OFF disables it.
CONC_PRECISION	—	1	AUTO, 0, 1, 2, 3, 4	Number of digits to display to the right of the decimal point for concentrations on the display. Enclose value in double quotes (") when setting from the RS-232 interface.
CLOCK_ADJ	Sec./Day	0	-60–60	Time-of-day clock speed adjustment.
LANGUAGE_SELECT	—	ENGL	ENGL, SECD, EXTN	Selects the language to use for the user interface. Enclose value in double quotes (") when setting from the RS-232 interface.
MAINT_TIMEOUT	Hours	2	0.1–100	Time until automatically switching out of software-controlled maintenance mode.
CONV_TIME	—	33 MS	33 MS, 66 MS, 133 MS, 266 MS, 533 MS, 1 SEC, 2 SEC	Conversion time for PMT and UV detector channels. Enclose value in double quotes (") when setting from the RS-232 interface.
DWELL_TIME	Seconds	1	0.1–10	Dwell time before taking each sample.
FILT_SIZE	Samples	30	1–480	Moving average filter size.
FILT_ASIZE	Samples	6	1–100	Moving average filter size in adaptive mode.
FILT_DELTA	PPM	10	1–100	Absolute change to trigger adaptive filter.
FILT_PCT	%	5	1–100	Percent change to trigger adaptive filter.
FILT_DELAY	Seconds	180	0–300	Delay before leaving adaptive filter mode.
FILT_ADAPT	—	ON	OFF, ON	ON enables adaptive filter; OFF disables it.
DIL_FACTOR	—	1	0.1–1000	Dilution factor if dilution

SETUP VARIABLE	NUMERIC UNITS	DEFAULT VALUE	VALUE RANGE	DESCRIPTION
				enabled with <i>FACTORY_OPT</i> variable.
USER_UNITS	—	PPM	PPM, UGM	Concentration units for user interface. Enclose value in double quotes (") when setting from the RS-232 interface.
LAMP_CAL	mV	3500	1000–5000	Last calibrated UV lamp reading.
LAMP_GAIN	—	0.9	0.5–1.5	UV lamp compensation attenuation factor.
TEMPCO_GAIN	—	0	0–2	Temperature coefficient attenuation factor for pressure readings.
SLOPE_CONST	—	6.25	0.1–10	Constant to make visible slope close to 1.
DARK_ENABLE	—	ON	OFF, ON	ON enables PMT/UV dark calibration; OFF disables it.
DARK_FREQ	Minutes	30,	0.1–1440	Dark calibration period.
DARK_LAMP_OFF	Seconds	1	0.01–10	Dark calibration lamp off period.
DARK_PRE_DWELL	Seconds	10	1–60	Dwell time after closing dark shutter or turning off lamp or selecting preamp range.
DARK_POST_DWELL	Seconds	30	1–180	Dwell time after opening dark shutter or turning on lamp.
DARK_SAMPLES	Samples	5	1–10	Number of dark samples to average.
DARK_FSIZE	Samples	2	1–100	Dark offset moving average filter size.
DARK_LIMIT	mV	400	0–1000	Maximum dark offset allowed.
SO2_SPAN1	Conc	4000	0.1–50000	Target SO <sub>2</sub> concentration during span calibration of range 1.
SO2_SLOPE1	PPM/mV	1	0.25–4	SO <sub>2</sub> slope for range 1.
SO2_OFFSET1	mV	0	-1500–1500	SO <sub>2</sub> offset for range 1.
SO2_SPAN2	Conc	4000	0.1–50000	Target SO <sub>2</sub> concentration during span calibration of range 2.
SO2_SLOPE2	PPM/mV	1	0.25–4	SO <sub>2</sub> slope for range 2.
SO2_OFFSET2	mV	0	-1500–1500	SO <sub>2</sub> offset for range 2.
RANGE_MODE	—	SNGL	SNGL, DUAL, AUTO, AUTO2	Range control mode. Enclose value in double quotes (") when setting from the RS-232 interface.
PHYS_RANGE1	PPM	500	5–10000	Low pre-amp range.
PHYS_RANGE2	PPM	5500	5–10000	High pre-amp range.
CONC_RANGE1	Conc	5000	0.1–50000	D/A concentration range 1.
CONC_RANGE2	Conc	5000	0.1–50000	D/A concentration range 2.
SAMP_FLOW_SET	cc/m	700	0–1200	Sample flow set point for flow

SETUP VARIABLE	NUMERIC UNITS	DEFAULT VALUE	VALUE RANGE	DESCRIPTION
				calculation and warning limits.
SAMP_FLOW_SLOPE	—	1 Warnings: 350–1200	0.5–1.5	Sample flow slope correction factor (adjusted flow = measured flow x slope).
VAC_SAMP_RATIO	—	0.53	0.1–2	Maximum vacuum pressure / sample pressure ratio for valid sample flow calculation.
SAMP_PRESS_SET	"Hg	29.92 Warnings: 15–35	0–100	Sample pressure set point for pressure compensation and warning limits.
SAMP_PRESS_SLOPE	—	1	0.5–1.5	Sample pressure slope correction factor (adjusted pressure = measured pressure x slope).
VAC_PRESS_SET	"Hg	6 Warnings: 3–10	0–100	Vacuum pressure set point for pressure compensation and warning limits.
BOX_SET	°C	30 Warnings: 8–50	5–60	Box temperature warning limits. Set point is not used.
PMT_SET	°C	7 Warnings: 2–12	0–40	PMT temperature set point and warning limits.
RS232_MODE	BitFlag	0	0–65535	RS-232 COM1 mode flags. Add values to combine flags. 1 = quiet mode 2 = computer mode 4 = enable security 16 = enable Hessen protocol <i>Must power-cycle instrument for these options to fully take effect.</i> 32 = enable multi-drop 64 = enable modem 128 = ignore RS-232 line errors 256 = disable XON / XOFF support 512 = disable hardware FIFOs 1024 = enable RS-485 mode 2048 = even parity, 7 data bits, 1 stop bit 4096 = enable command prompt
BAUD_RATE	—	19200	300, 1200, 2400,	RS-232 COM1 baud rate. Enclose value in double quotes (") when setting from the RS-

SETUP VARIABLE	NUMERIC UNITS	DEFAULT VALUE	VALUE RANGE	DESCRIPTION
			4800, 9600, 19200, 38400, 57600, 115200	232 interface.
<b>MODEM_INIT</b>	—	"AT Y0 &D0 &H0 &I0 S0=2 &B0 &N6 &M0 E0 Q1 &W0"	Any character in the allowed character set. Up to 100 characters long.	RS-232 COM1 modem initialization string. Sent verbatim plus carriage return to modem on power up or manually. Enclose value in double quotes (") when setting from the RS-232 interface.
<b>RS232_MODE2</b>	BitFlag	0	0–65535	RS-232 COM2 mode flags. (Same settings as RS232_MODE.)
<b>BAUD_RATE2</b>	—	19200	300, 1200, 2400, 4800, 9600, 19200, 38400, 57600, 115200	RS-232 COM2 baud rate. Enclose value in double quotes (") when setting from the RS-232 interface.
<b>MODEM_INIT2</b>	—	"AT Y0 &D0 &H0 &I0 S0=2 &B0 &N6 &M0 E0 Q1 &W0"	Any character in the allowed character set. Up to 100 characters long.	RS-232 COM2 modem initialization string. Sent verbatim plus carriage return to modem on power up or manually. Enclose value in double quotes (") when setting from the RS-232 interface.
<b>RS232_PASS</b>	Password	940331	0–999999	RS-232 log on password.
<b>MACHINE_ID</b>	ID	100	0–9999	Unique ID number for instrument.
<b>COMMAND_PROMPT</b>	—	"Cmd> "	Any character in the allowed character set. Up to 100 characters long.	RS-232 interface command prompt. Displayed only if enabled with RS232_MODE variable. Enclose value in double quotes (") when setting from the RS-232 interface.
<b>TEST_CHAN_ID</b>	—	NONE	NONE, PMT READING, UV READING, VACUUM PRESSURE, SAMPLE PRESSURE, SAMPLE FLOW, RCELL TEMP, CHASSIS TEMP, PMT TEMP, HVPS VOLTAGE	Diagnostic analog output ID. Enclose value in double quotes (") when setting from the RS-232 interface.
<b>REMOTE_CAL_MODE</b>	—	LOW	LOW, HIGH	Range to calibrate during contact-closure and Hessen calibration. Enclose value in double quotes (") when setting

SETUP VARIABLE	NUMERIC UNITS	DEFAULT VALUE	VALUE RANGE	DESCRIPTION
				from the RS-232 interface.
PASS_ENABLE	—	OFF	OFF, ON	ON enables passwords; OFF disables them.
STABIL_FREQ	Seconds	10	1–300	Stability measurement sampling period.
STABIL_SAMPLES	Samples	25	2–40	Number of samples in concentration stability reading.
RCELL_CYCLE	Seconds	2	0.5–30	Reaction cell temperature control cycle period.
RCELL_PROP	1/°C	0.3 (prop. band = 3.3 °C)	0–10	Reaction cell temperature PID proportional coefficient.
RCELL_INTEG	—	0.005	0–10	Reaction cell temperature PID integral coefficient.
RCELL_DERIV	—	0.5	0–10	Reaction cell temperature PID derivative coefficient.
HVPS_SET	Volts	550 Warnings: 400–700	0–2000	High voltage power supply warning limits. Set point is not used.
DETECTOR_LIMIT	mV	1000 Warnings: 600–4995	0–5000	UV lamp and PMT detector warning limits. Set point is not used.
SERIAL_NUMBER	—	"00000000" "	Any character in the allowed character set. Up to 100 characters long.	Unique serial number for instrument. Enclose value in double quotes (") when setting from the RS-232 interface.
DISP_INTENSITY	—	HIGH	HIGH, MED, LOW, DIM	Front panel display intensity. Enclose value in double quotes (") when setting from the RS-232 interface.
I2C_RESET_ENABLE	—	ON	OFF, ON	I <sup>2</sup> C bus automatic reset enable.
CLOCK_FORMAT	—	"TIME=%H:%M:%S"	Any character in the allowed character set. Up to 100 characters long.	Time-of-day clock format flags. Enclose value in double quotes (") when setting from the RS-232 interface. "%a" = Abbreviated weekday name. "%b" = Abbreviated month name. "%d" = Day of month as decimal number (01 – 31). "%H" = Hour in 24-hour format (00 – 23). "%I" = Hour in 12-hour format (01 – 12). "%j" = Day of year as decimal number (001 – 366).

SETUP VARIABLE	NUMERIC UNITS	DEFAULT VALUE	VALUE RANGE	DESCRIPTION
				"%m" = Month as decimal number (01 – 12). "%M" = Minute as decimal number (00 – 59). "%p" = A.M./P.M. indicator for 12-hour clock. "%S" = Second as decimal number (00 – 59). "%w" = Weekday as decimal number (0 – 6; Sunday is 0). "%y" = Year without century, as decimal number (00 – 99). "%Y" = Year with century, as decimal number. "%%" = Percent sign.
<b>FACTORY_OPT</b>	BitFlag	0	0–65535	Factory option flags. Add values to combine flags. 1 = enable dilution factor 2 = zero/span valves installed 4 = IZS installed (implies zero/span valves installed) 8 = low span valve installed 16 = display units in concentration field 32 = enable software-controlled maintenance mode 64 = enable lamp power analog output 128 = enable switch-controlled maintenance mode 2048 = enable Internet option

APPENDIX A-3: Warnings and Test Functions, Revision C.0

Table A-2: M100EH Warning Messages, Revision C.0

NAME	MESSAGE TEXT	DESCRIPTION
WSYSRES	<b>SYSTEM RESET</b>	Instrument was power-cycled or the CPU was reset.
WDATAINIT	<b>DATA INITIALIZED</b>	Data storage was erased.
WCONFIGINIT	<b>CONFIG INITIALIZED</b>	Configuration storage was reset to factory configuration or erased.
WPMT	<b>PMT DET WARNING</b>	PMT detector outside of warning limits specified by <i>DETECTOR_LIMIT</i> variable.
WUVLAMP	<b>UV LAMP WARNING</b>	UV lamp reading outside of warning limits specified by <i>DETECTOR_LIMIT</i> variable.
WSAMPFLOW	<b>SAMPLE FLOW WARN</b>	Sample flow outside of warning limits specified by <i>SAMP_FLOW_SET</i> variable.

NAME	MESSAGE TEXT	DESCRIPTION
WSAMPPRESS	<b>SAMPLE PRESS WARN</b>	Sample pressure outside of warning limits specified by <i>SAMP_PRESS_SET</i> variable.
WVACPRESS	<b>VACUUM PRESS WARN</b>	Vacuum pressure outside of warning limits specified by <i>VAC_PRESS_SET</i> variable.
WBOXTEMP	<b>BOX TEMP WARNING</b>	Chassis temperature outside of warning limits specified by <i>BOX_SET</i> variable.
WRCELLTEMP	<b>RCELL TEMP WARNING</b>	Reaction cell temperature outside of warning limits specified by <i>RCELL_SET</i> variable.
WIZSTEMP	<b>IZS TEMP WARNING</b>	IZS temperature outside of warning limits specified by <i>IZS_SET</i> variable.
WPMTTEMP	<b>PMT TEMP WARNING</b>	PMT temperature outside of warning limits specified by <i>PMT_SET</i> variable.
WDARKCAL	<b>DARK CAL WARNING</b>	Dark offset above limit specified by <i>DARK_LIMIT</i> variable.
WHVPS	<b>HVPS WARNING</b>	High voltage power supply output outside of warning limits specified by <i>HVPS_SET</i> variable.
WDYNZERO	<b>CANNOT DYN ZERO</b>	Contact closure zero calibration failed while <i>DYN_ZERO</i> was set to <i>ON</i> .
WDYNSPAN	<b>CANNOT DYN SPAN</b>	Contact closure span calibration failed while <i>DYN_SPAN</i> was set to <i>ON</i> .
WREARBOARD	<b>REAR BOARD NOT DET</b>	Rear board was not detected during power up.
WRELAYBOARD	<b>RELAY BOARD WARN</b>	Firmware is unable to communicate with the relay board.
WFRONTPANEL	<b>FRONT PANEL WARN</b>	Firmware is unable to communicate with the front panel.
WANALOGCAL	<b>ANALOG CAL WARNING</b>	The A/D or at least one D/A channel has not been calibrated.

Table A-3: M100EH Test Functions, Revision C.0

TEST FUNCTION	MESSAGE TEXT	DESCRIPTION
RANGE	RANGE=500.0 PPB	D/A range in single or auto-range modes.
RANGE1	RANGE1=500.0 PPB	D/A #1 range in independent range mode.
RANGE2	RANGE2=500.0 PPB	D/A #2 range in independent range mode.
STABILITY	STABIL=0.0 PPB	Concentration stability (standard deviation based on setting of <i>STABIL_FREQ</i> and <i>STABIL_SAMPLES</i> ).
VACUUM	VAC=9.1 IN-HG-A	Vacuum pressure.
SAMPPRESS	PRES=29.9 IN-HG-A	Sample pressure.
SAMPFLOW	SAMP FL=700 CC/M	Sample flow rate.
PMTDET	PMT=762.5 MV	Raw PMT reading.
NORMPMTDET	NORM PMT=742.9 MV	PMT reading normalized for temperature, pressure, auto-zero offset, but not range.
UVDET	UV LAMP=3457.6 MV	UV lamp reading.
LAMP RATIO	LAMP RATIO=100.0 %	UV lamp ratio of current reading divided by calibrated reading.
STRAYLIGHT	STR. LGT=0.1 PPB	Stray light offset.
DARKPMT	DRK PMT=19.6 MV	PMT dark offset.
DARKLAMP	DRK LMP=42.4 MV	UV lamp dark offset.
SLOPE	SLOPE=1.061	Slope for current range, computed during zero/span calibration.
OFFSET	OFFSET=250.0 MV	Offset for current range, computed during zero/span calibration.
HVPS	HVPS=650 VOLTS	High voltage power supply output.
RCELLDUTY	RCELL ON=0.00 SEC	Reaction cell temperature control duty cycle.
RCELLTEMP	RCELL TEMP=52.1 C	Reaction cell temperature.
BOXTEMP	BOX TEMP=35.5 C	Internal chassis temperature.
PMTTEMP	PMT TEMP=7.0 C	PMT temperature.
IZSDUTY	IZS ON=0.00 SEC	IZS temperature control duty cycle.
IZSTEMP	IZS TEMP=52.2 C	IZS temperature.
SO2	SO2=261.4 PPB	SO <sub>2</sub> concentration for current range.
TESTCHAN	TEST=3721.1 MV	Value output to <i>TEST_OUTPUT</i> analog output, selected with <i>TEST_CHAN_ID</i> variable.
CLOCKTIME	TIME=10:38:27	Current instrument time of day clock.

**APPENDIX A-4: M100EH Signal I/O Definitions, Revision C.0**

**Table A-4: M100EH Signal I/O Definitions, Revision C.0**

SIGNAL NAME	BIT OR CHANNEL NUMBER	DESCRIPTION
<b>Internal inputs, U7, J108, pins 9–16 = bits 0–7, default I/O address 322 hex</b>		
	0–7	Spare
<b>Internal outputs, U8, J108, pins 1–8 = bits 0–7, default I/O address 322 hex</b>		
ELEC_TEST	0	1 = electrical test on 0 = off
OPTIC_TEST	1	1 = optic test on 0 = off
PREAMP_RANGE_HI	2	1 = select high preamp range 0 = select low range
	3–5	Spare
I2C_RESET	6	1 = reset I <sup>2</sup> C peripherals 0 = normal
I2C_DRV_RST	7	0 = hardware reset 8584 chip 1 = normal
<b>Control inputs, U11, J1004, pins 1–6 = bits 0–5, default I/O address 321 hex</b>		
EXT_ZERO_CAL	0	0 = go into zero calibration 1 = exit zero calibration
EXT_SPAN_CAL	1	0 = go into span calibration 1 = exit span calibration
EXT_LOW_SPAN	2	0 = go into low span calibration 1 = exit low span calibration
	3–5	Spare
	6–7	Always 1
<b>Control inputs, U14, J1006, pins 1–6 = bits 0–5, default I/O address 325 hex</b>		
	0–5	Spare
	6–7	Always 1
<b>Control outputs, U17, J1008, pins 1–8 = bits 0–7, default I/O address 321 hex</b>		
	0–7	Spare
<b>Control outputs, U21, J1008, pins 9–12 = bits 0–3, default I/O address 325 hex</b>		
	0–3	Spare
<b>Alarm outputs, U21, J1009, pins 1–12 = bits 4–7, default I/O address 325 hex</b>		
ST_SYSTEM_OK2	4	1 = system OK 0 = any alarm condition or in diagnostics mode
	5–7	Spare
<b>A status outputs, U24, J1017, pins 1–8 = bits 0–7, default I/O address 323 hex</b>		
ST_SYSTEM_OK	0	0 = system OK 1 = any alarm condition
ST_CONC_VALID	1	0 = conc. valid

SIGNAL NAME	BIT OR CHANNEL NUMBER	DESCRIPTION
		1 = warnings or other conditions that affect validity of concentration
ST_HIGH_RANGE	2	0 = high auto-range in use 1 = low auto-range
ST_ZERO_CAL	3	0 = in zero calibration 1 = not in zero
ST_SPAN_CAL	4	0 = in span calibration 1 = not in span
ST_DIAG_MODE	5	0 = in diagnostic mode 1 = not in diagnostic mode
ST_LOW_SPAN_CAL	6	0 = in low span calibration 1 = not in low span
	7	Spare
<b>B status outputs, U27, J1018, pins 1–8 = bits 0–7, default I/O address 324 hex</b>		
ST_LAMP_ALARM	0	0 = lamp intensity low 1 = lamp intensity OK
ST_DARK_CAL_ALARM	1	0 = dark cal. warning 1 = dark cal. OK
ST_FLOW_ALARM	2	0 = any flow alarm 1 = all flows OK
ST_PRESS_ALARM	3	0 = any pressure alarm 1 = all pressures OK
ST_TEMP_ALARM	4	0 = any temperature alarm 1 = all temperatures OK
ST_HVPS_ALARM	5	0 = HVPS alarm 1 = HVPS OK
	6–7	Spare
<b>Front panel I<sup>2</sup>C keyboard, default I<sup>2</sup>C address 4E hex</b>		
MAINT_MODE	5 (input)	0 = maintenance mode 1 = normal mode
LANG2_SELECT	6 (input)	0 = select second language 1 = select first language (English)
SAMPLE_LED	8 (output)	0 = sample LED on 1 = off
CAL_LED	9 (output)	0 = cal. LED on 1 = off
FAULT_LED	10 (output)	0 = fault LED on 1 = off
AUDIBLE_BEEPER	14 (output)	0 = beeper on (for diagnostic testing only) 1 = off
<b>Relay board digital output (PCF8575), default I<sup>2</sup>C address 44 hex</b>		
RELAY_WATCHDOG	0	Alternate between 0 and 1 at least every 5 seconds

SIGNAL NAME	BIT OR CHANNEL NUMBER	DESCRIPTION
		to keep relay board active
RCELL_HEATER	1	0 = reaction cell heater on 1 = off
	2–3	Spare
IZS_HEATER	4	0 = IZS heater on 1 = off
	5	Spare
CAL_VALVE	6	0 = let cal. gas in 1 = let sample gas in
SPAN_VALVE	7	0 = let span gas in 1 = let zero gas in
LOW_SPAN_VALVE	8	0 = let low span gas in 1 = let sample gas in
ZERO_VALVE	9	0 = let zero gas in 1 = let sample gas in
DARK_SHUTTER	10	0 = close dark shutter 1 = open
	11–15	Spare
<b>Rear board primary MUX analog inputs</b>		
PMT_SIGNAL	0	PMT detector
HVPS_VOLTAGE	1	HV power supply output
PMT_TEMP	2	PMT temperature
UVLAMP_SIGNAL	3	UV lamp intensity
	4	Temperature MUX
	5–6	Spare
SAMPLE_PRESSURE	7	Sample pressure
TEST_INPUT_8	8	Diagnostic test input
REF_4096_MV	9	4.096V reference from MAX6241
SAMPLE_FLOW	10	Sample flow rate
VACUUM_PRESSURE	10	Vacuum pressure
TEST_INPUT_11	11	Diagnostic test input
	12–13	Spare (thermocouple input?)
	14	DAC MUX
REF_GND	15	Ground reference
<b>Rear board temperature MUX analog inputs</b>		
BOX_TEMP	0	Internal box temperature
RCELL_TEMP	1	Reaction cell temperature
IZS_TEMP	2	IZS temperature
	3	Spare
TEMP_INPUT_4	4	Diagnostic temperature input
TEMP_INPUT_5	5	Diagnostic temperature input

SIGNAL NAME	BIT OR CHANNEL NUMBER	DESCRIPTION
TEMP_INPUT_6	6	Diagnostic temperature input
	7	Spare
<b>Rear board DAC MUX analog inputs</b>		
DAC_CHAN_0	0	DAC channel 0 loopback
DAC_CHAN_1	1	DAC channel 1 loopback
DAC_CHAN_2	2	DAC channel 2 loopback
DAC_CHAN_3	3	DAC channel 3 loopback
<b>Rear board analog outputs</b>		
CONC_OUT_1	0	Concentration output #1
CONC_OUT_2	1	Concentration output #2
TEST_OUTPUT	2	Test measurement output
	3	Spare

## APPENDIX A-5: M100EH iDAS Functions, Revision C.0

Table A-5: M100EH DAS Trigger Events, Revision C.0

NAME	DESCRIPTION
ATIMER	Automatic timer expired
EXITZR	Exit zero calibration mode
EXITLS	Exit low span calibration mode
EXITHS	Exit high span calibration mode
EXITMP	Exit multi-point calibration mode
SLPCHG	Slope and offset recalculated
EXITDG	Exit diagnostic mode
PMTDTW	PMT detector warning
UVLMPW	UV lamp warning
RCTMPW	Reaction cell temperature warning
PTEMPW	PMT temperature warning
SFLOWW	Sample flow warning
SPRESW	Sample pressure warning
VPRESW	Vacuum pressure warning
BTEMPW	Box temperature warning
HVPSW	High voltage power supply warning

Table A-6: M100EH iDAS Functions, Revision C.0

NAME	DESCRIPTION	UNITS
PMTDET	PMT detector reading	mV
UVDET	UV lamp intensity reading	mV
LAMPR	UV lamp ratio of calibrated intensity	%
DRKPMT	PMT electrical offset	mV
DARKUV	UV lamp electrical offset	mV
SLOPE1	SO <sub>2</sub> slope for range #1	—
SLOPE2	SO <sub>2</sub> slope for range #2	—
OFSET1	SO <sub>2</sub> offset for range #1	mV
OFSET2	SO <sub>2</sub> offset for range #2	mV
ZSCNC1	SO <sub>2</sub> concentration for range #1 during zero/span calibration, just before computing new slope and offset	PPB
ZSCNC2	SO <sub>2</sub> concentration for range #2 during zero/span calibration, just before computing new slope and offset	PPB
CONC1	SO <sub>2</sub> concentration for range #1	PPB
CONC2	SO <sub>2</sub> concentration for range #2	PPB
STABIL	SO <sub>2</sub> concentration stability	PPB
STRLGT	Stray light reading	PPB
RCTEMP	Reaction cell temperature	°C
PMTTMP	PMT temperature	°C
SMPFLW	Sample flow	cc/m
SMPPRS	Sample pressure	"Hg
VACUUM	Vacuum pressure	"Hg
BOXTMP	Internal box temperature	°C
HVPS	High voltage power supply output	Volts
TEST8	Diagnostic test input (TEST_INPUT_8)	mV
TEST11	Diagnostic test input (TEST_INPUT_11)	mV
TEMP4	Diagnostic temperature input (TEMP_INPUT_4)	°C
TEMP5	Diagnostic temperature input (TEMP_INPUT_5)	°C
TEMP6	Diagnostic temperature input (TEMP_INPUT_6)	°C
REFGND	Ground reference (REF_GND)	mV
RF4096	4096 mV reference (REF_4096_MV)	mV

APPENDIX A-6: Terminal Command Designators, Revision C.0

Table A-7: Terminal Command Designators, Revision C.0

COMMAND	ADDITIONAL COMMAND SYNTAX	DESCRIPTION
? [ID]		Display help screen and this list of commands
LOGON [ID]	password	Establish connection to instrument
LOGOFF [ID]		Terminate connection to instrument
T [ID]	SET ALL name hexmask	Display test(s)
	LIST [ALL name hexmask] [NAMES HEX]	Print test(s) to screen
	name	Print single test
	CLEAR ALL name hexmask	Disable test(s)
W [ID]	SET ALL name hexmask	Display warning(s)
	LIST [ALL name hexmask] [NAMES HEX]	Print warning(s)
	name	Clear single warning
	CLEAR ALL name hexmask	Clear warning(s)
C [ID]	ZERO LOWSPAN SPAN [1 2]	Enter calibration mode
	ASEQ number	Execute automatic sequence
	COMPUTE ZERO SPAN	Compute new slope/offset
	EXIT	Exit calibration mode
	ABORT	Abort calibration sequence
D [ID]	LIST	Print all I/O signals
	name[=value]	Examine or set I/O signal
	LIST NAMES	Print names of all diagnostic tests
	ENTER name	Execute diagnostic test
	EXIT	Exit diagnostic test
	RESET [DATA] [CONFIG] [exitcode]	Reset instrument
	PRINT ["name"] [SCRIPT]	Print iDAS configuration
	RECORDS ["name"]	Print number of iDAS records
	REPORT ["name"] [RECORDS=number] [FROM=<start date>][TO=<end date>][VERBOSE COMPACT HEX] (Print DAS records)(date format: MM/DD/YYYY(or YY) [HH:MM:SS])	Print iDAS records
CANCEL	Halt printing iDAS records	
V [ID]	LIST	Print setup variables
	name[=value [warn_low [warn_high]]]	Modify variable
	name="value"	Modify enumerated variable
	CONFIG	Print instrument configuration
	MAINT ON OFF	Enter/exit maintenance mode
	MODE	Print current instrument mode
	DASBEGIN [<data channel definitions>] DASEND	Upload iDAS configuration
	CHANNELBEGIN propertylist CHANNELEND	Upload single iDAS channel
	CHANNELDELETE ["name"]	Delete iDAS channels

The command syntax follows the command type, separated by a space character. Strings in [brackets] are optional designators. The following key assignments also apply.

<b>TERMINAL KEY ASSIGNMENTS</b>	
ESC	Abort line
CR (ENTER)	Execute command
Ctrl-C	Switch to computer mode
<b>COMPUTER MODE KEY ASSIGNMENTS</b>	
LF (line feed)	Execute command
Ctrl-T	Switch to terminal mode

---

## USER NOTES:



## APPENDIX B - M100EH Spare Parts List

**NOTE**

Use of replacement parts other than those supplied by API may result in non-compliance with European standard EN 61010-1.

- 04624 – Spare Parts List, M100EH
- 04527 – Recommended Spare Parts Stocking Levels, M100EH
- 0435701 – Kit, Expendables, M100EH



## M100EH Spare Parts List

Part Number	Description
000940400	CD, ORIFICE, .004 BLUE
000940800	ORIFICE, 12 MIL, SAMPLE FLOW
002690000	LENS, UV
002700000	LENS, PMT
002740000	FILTER, PMT OPTICAL, 360 NM
005960000	KIT, EXPENDABLES, ACTIVATED CHARCOAL
006900000	RETAINER PAD, CHARCOAL SCRUBBER
009690000	KIT, TFE FILTER ELEMENTS, 5 UM (100)
009690100	KIT, TFE FILTER ELEMENTS, 5 UM (30)
013140000	ASSY, COOLER FAN (NOX/SOX)
013400000	PMT, SO2
013420000	ASSY, ROTARY SOLENOID
013570000	ASSY, THERMISTOR (COOLER)
014080100	ASSY, HVPS
014750000	AKIT, EXP KIT, M100A/M100E, IZS
016290000	WINDOW, SAMPLE FILTER
016300700	ASSY, SAMPLE FILTER, 47MM
018080000	KIT, DESSICANT BAGGIES (12)
023410000	ASSY, PRESSURE/FLOW MODULE
036850000	PLUG, SEALING, INLET MANIFOLD
037860000	ORING, TFE RETAINER, SAMPLE FILTER
040010000	ASSY, FAN, REAR PANEL
041620200	ASSY, SO2 SENSOR, M100EH
041710000	ASSY, CPU, CONFIGURATION
041800400	PCA, PMT PREAMP, VR, M100E (KB)
042580000	PCA, KEYBOARD, E-SERIES, W/V-DETECT
042900100	PROGRAMMED FLASH, E SERIES
043570100	AKIT, EXPENDABLES, M100EH
043940000	PCA, INTERFACE, ETHERNET
045150100	MANUAL, OPERATION, M100E
045230200	PCA, RELAY CARD W/RELAYS, E SERIES
045870100	PCA, REF DETECTOR
046210000	ADDENDUM, MANUAL, M100EH
046250000	ASSY, RXCELL HEATER/FUSE
046260000	ASSY, THERMISTOR, RXCELL
048190100	ASSY, RELAY/PS, M100E/M200E/M400E
048620200	PCA, SERIAL INTERFACE
049310100	PCA, TEC CONTROL, E SERIES
050610100	CONFIGURATION PLUGS, 115V/60HZ
050610200	CONFIGURATION PLUGS, 115V/50HZ
050610300	CONFIGURATION PLUGS, 220-240V/50HZ
050610400	CONFIGURATION PLUGS, 220-240V/60HZ
050610500	CONFIGURATION PLUGS, 100V/50HZ
050610600	CONFIGURATION PLUGS, 100V/60HZ
050830100	DOC, w/SOFTWARE, M100EH
051990000	ASSY, SCRUBBER, INLINE EXHAUST, DISPOS
053020100	ASSY, INLET MANIFOLD VALVE, ZERO/SPAN
053020200	ASSY, INLET MANIFOLD VALVE, SAMPLE

## M100EH Spare Parts List

Part Number	Description
058021100	PCA, E-SERIES MOTHERBOARD, GEN 5-I
061930000	PCA, UV LAMP DRIVER, GEN-2
CN0000458	CONNECTOR, REAR PANEL, 12 PIN
CN0000520	CONNECTOR, REAR PANEL, 10 PIN
DS0000025	DISPLAY
FL0000001	FILTER, SS
FL0000003	FILTER, DFU
HW0000005	FOOT, PUMP PACK
HW0000036	TFE TAPE, 1/4" (48 FT/ROLL)
HW0000090	SPRING, SS, FLOW CONTROL
HW0000093	SPRING, CHARCOAL SCRUBBER
HW0000101	ISOLATOR, PUMP PACK
HW0000149	SEALING WASHER, INLET VALVE
KIT000093	KIT, 214NM FILTER REPLACEMENT
KIT000095	KIT, COOLER REPLACEMENT
KIT000207	KIT, M100E RELAY RETROFIT
KIT000219	KIT, 4-20MA CURRENT OUTPUT (E SERIES)
KIT000236	KIT, UV LAMP, w/E-A ADAPTER (BIR)
KIT000253	KIT, SPARE PS37, E SERIES
KIT000254	KIT, SPARE PS38, E SERIES
OR0000001	ORING, FLOW CONTROL
OR0000004	ORING, OPTIC/CELL, CELL/TRAP
OR0000006	ORING, CELL/PMT
OR0000007	ORING, PMT/BARREL/CELL
OR0000015	ORING, PMT FILTER
OR0000016	ORING, UV LENS
OR0000025	ORING, CHARCOAL SCRUBBER
OR0000027	ORING, COLD BLOCK/PMT HOUSING & HEATSINK
OR0000048	ORING, REF DETECTOR
OR0000050	ORING, SEALING PLUG, INLET MANIFOLD
OR0000051	ORING, SEALING PLUG, INLET MANIFOLD
OR0000060	ORING, PRESSURE TRANSDUCER
OR0000083	ORING, PMT SIGNAL & OPTIC LED
OR0000084	ORING, UV FILTER
OR0000094	ORING, SAMPLE FILTER
PU0000005	PUMP, THOMAS 607, 115V/60HZ
PU0000006	PUMP, THOMAS 607, 220V/50HZ
PU0000011	KIT, THOMAS 607 REBUILD
PU0000054	PUMP, THOMAS 688, 100V/50-60HZ
PU0000064	KIT, THOMAS 688 REBUILD
RL0000015	RELAY, DPDT
SW0000051	SWITCH, POWER, CIRCUIT BREAKER
SW0000059	PRESSURE SENSOR, 0-15 PSIA, ALL SEN
WR0000008	POWER CORD, 10A

## Recommended Spare Parts Stocking Levels Model 100EH

Part Number	Description	1	2-5	6-10	11-20	21-30	UNITS
000940800	CD, ORIFICE, .012 (NO PAINT)		1	2	4	4	
002740000	CD FILTER, PMT 360NM				1	2	
013400000	CD, PMT, SO2, M100A/E (KB)				1	1	
014080100	ASSY, HVPS, SOX/NOX					1	
014610000	KIT, REPLACEMENT COOLER ASSY, M100X/200X					1	
023400000	BEAM SPLITTER, M100AH/EH				1	2	
023410000	ASSY, FLOW MODULE, M100AH/EH			1	2	3	
040010000	ASSY, FAN REAR PANEL, E SERIES	1	1	2	4	4	
040030100	PCA, PRESS SENSORS (1X), w/FM4, E SERIES		1	2	4	4	
041710000	ASSY, CPU, CONFIGURATION, "E" SERIES *				1	1	
041800400	PCA, PMT PREAMP, VR, M100E (KB)				1	1	
042410200	42410200: For 240V operation, use 055100200					1	
042580000	PCA, KEYBOARD, E-SERIES, W/V-DETECT				1	1	
045230200	PCA, RELAY CARD, M100E/200E			1	1	2	
045870100	PCA, REF DETECTOR PREAMP, W/ADJ, M100EH				1	2	
055100200	OPTION, PUMP ASSY, 240V *		1	2	4	4	
055560000	ASSY, VALVE, VA59 W/DIODE, 5" LEADS				1	1	**
058021100	PCA, E-SERIES MOTHERBOARD, GEN 5-I		1	1	2	2	
061930000	PCA, UV LAMP DRIVER, GEN-2		1	2	2	4	With IZS, ZS Option
DS0000025	DISPLAY, E SERIES (KB)				1	2	
FM0000004	FLOWMETER (KB)				1	1	
KIT000236	KIT, UV LAMP, w/E-A ADAPTER (BIR)				1	1	
OP0000030	OXYGEN TRANSDUCER, PARAMAGNETIC					1	With O2 Option
SW0000059	PRESSURE SENSOR, 0-15 PSIA, ALL SEN					1	

\*\* For 240V operation, use 055100200

## M100E/EH Expendables Kit

Part Number	Description	Quantity
018080000	KIT, DESSICANT BAGGIES (12)	1
FL0000001	FILTER, SS	1
HW0000020	SPRING	1
OR0000001	ORING, FLOW CONTROL	1

# Warranty/Repair Questionnaire Model 100EH

CUSTOMER: \_\_\_\_\_ PHONE: \_\_\_\_\_

CONTACT NAME: \_\_\_\_\_ FAX NO. \_\_\_\_\_

SITE ADDRESS: \_\_\_\_\_

MODEL 100EH SERIAL NO.: \_\_\_\_\_ FIRMWARE REVISION: \_\_\_\_\_

1. ARE THERE ANY FAILURE MESSAGES? \_\_\_\_\_  
\_\_\_\_\_  
\_\_\_\_\_

PLEASE COMPLETE THE FOLLOWING TABLE: (NOTE: *DEPENDING ON OPTIONS INSTALLED, NOT ALL TEST PARAMETERS SHOWN BELOW WILL BE AVAILABLE IN YOUR INSTRUMENT*)

Parameter	Displayed As	Observed Value	Units	Nominal Range
Range	<b>RANGE</b>		PPM UG/M <sup>3</sup>	1-5000 PPM Standard
Stability	<b>STABIL</b>		PPM UG/M <sup>3</sup>	<.1 PPM with Zero Air
Vacuum	<b>VACUUM</b>		"Hg	4 – 10 "Hg
Sample Pressure	<b>PRES</b>		In-Hg-A	24 – 29
Sample Flow	<b>SAMP FL</b>		CC/MIN	700 ±10%
PMT Signal	<b>PMT</b>		MV	0 ± 100 with Zero Air
Normalized PMT Signal	<b>NORM PMT</b>		MV	0 ± 100 with Zero Air
UV Lamp	<b>UV LAMP</b>		MV	1000 – 4800
UV Lamp Ratio	<b>LAMP RATIO</b>		%	35 – 120%
Stray Light	<b>STR. LGT</b>		PPM	-50 to +100
Dark PMT	<b>DRK PMT</b>		MV	<200
Dark Lamp	<b>DRK LMP</b>		MV	-30 to 50
Slope	<b>SLOPE</b>		-	1.0 ± 0.3
Offset	<b>OFFSET</b>		MV	<200
High Voltage Power Supply	<b>HVPS</b>		V	400 – 750*
Reaction Cell Temperature	<b>RCELL TEMP</b>		°C	50 ± 1
Box Temperature	<b>BOX TEMP</b>		°C	Ambient + (3-7)
PMT Temperature	<b>PMT TEMP</b>		°C	7 ± 2
Time of Day	<b>TIME</b>		HH:MM:SS	

TELEDYNE API CUSTOMER SERVICE  
EMAIL: [api-customerservice@teledyne.com](mailto:api-customerservice@teledyne.com)  
PHONE: (858) 657-9800 TOLL FREE: (800) 324-5190 FAX: (858) 657-9816

# Warranty/Repair Questionnaire Model 100EH

Test Settings		
Test Value	Observed Value	Acceptable Value
ETEST PMT Reading		2000 ± 1000MV
OTEST PMT Reading		2000 ± 20 MV

2. HAVE YOU PERFORMED A LEAK CHECK AND FLOW CHECK? \_\_\_\_\_
3. WHAT ARE THE FAILURE SYMPTOMS? \_\_\_\_\_  
\_\_\_\_\_  
\_\_\_\_\_
4. WHAT TEST HAVE YOU DONE TRYING TO SOLVE THE PROBLEM? \_\_\_\_\_  
\_\_\_\_\_  
\_\_\_\_\_  
\_\_\_\_\_  
\_\_\_\_\_
5. IF POSSIBLE, PLEASE INCLUDE A PORTION OF A STRIP CHART PERTAINING TO THE PROBLEM. CIRCLE PERTINENT DATA.
6. THANK YOU FOR PROVIDING THIS INFORMATION. YOUR ASSISTANCE ENABLES TELEDYNE API TO RESPOND FASTER TO THE PROBLEM THAT YOU ARE ENCOUNTERING.

## APPENDIX D - ELECTRONIC SCHEMATICS

Table D-1: List of Included Electronic Schematics

DOCUMENT #	DOCUMENT TITLE
03956	PCA, 03955, Relay Driver
02173	PCA, 02172, Pressure Flow Sensor Board
05703	PCA, 05702, Motherboard, E-Series Gen 4
04181	PCA, 04180, PMT Preamp
04259	PCA, 04258, Keyboard Display Interface
01312	PCA, 04120, UV Detector Preamp
04693	PCA, UV Lamp Driver, M100EH
04932	PCA, Thermo-Electric Cooler Board
04468	PCA, Analog Output Series Res

