

# **INSTRUCTION MANUAL**

## ***MODEL 100A SULFUR DIOXIDE ANALYZER***

**TELEDYNE ADVANCED POLLUTION INSTRUMENTATION  
(T-API)  
9480 CARROLL PARK DRIVE  
SAN DIEGO, CA 92121-5201**

**TOLL-FREE: 800-324-5190  
FAX: 858-657-9816  
TEL: 858-657-9800  
E-MAIL: [api-sales@teledyne.com](mailto:api-sales@teledyne.com)  
WEB SITE: [www.teledyne-api.com](http://www.teledyne-api.com)**



# Table of Contents

<b>1 HOW TO USE THIS MANUAL</b> .....	<b>1-1</b>
1.1 SAFETY MESSAGES .....	1-2
<b>2 GETTING STARTED</b> .....	<b>2-1</b>
2.1 INSTALLATION .....	2-1
2.2 ELECTRICAL AND PNEUMATIC CONNECTIONS .....	2-1
2.3 INITIAL OPERATION .....	2-6
<b>3 SPECIFICATIONS, AGENCY APPROVALS, WARRANTY</b> .....	<b>3-1</b>
3.1 SPECIFICATIONS.....	3-1
3.2 EPA EQUIVALENCY DESIGNATION .....	3-2
3.3 WARRANTY .....	3-3
<b>4 THE M100A SO<sub>2</sub> ANALYZER</b> .....	<b>4-1</b>
4.1 PRINCIPLE OF OPERATION.....	4-1
4.2 INSTRUMENT DESCRIPTION .....	4-4
4.2.1 <i>Sensor Module, Reaction Cell, Detector</i> .....	4-4
4.2.2 <i>Pneumatic Sensor Board</i> .....	4-4
4.2.3 <i>Computer Hardware and Software</i> .....	4-4
4.2.4 <i>V/F Board</i> .....	4-5
4.2.5 <i>Front Panel</i> .....	4-5
4.2.6 <i>Power Supply Module</i> .....	4-8
4.2.7 <i>Pneumatic System</i> .....	4-8
<b>5 SOFTWARE FEATURES</b> .....	<b>5-1</b>
5.1 INDEX TO FRONT PANEL MENUS.....	5-1
5.1.1 <i>Sample Menu</i> .....	5-3
5.1.2 <i>Set-Up Menu</i> .....	5-4
5.2 SAMPLE MODE .....	5-7
5.2.1 <i>Test Functions</i> .....	5-7
5.2.2 <i>CAL, CALS, CALZ, Calibration Functions</i> .....	5-10
5.3 SET-UP MODE .....	5-12
5.3.1 <i>Configuration Information (CFG)</i> .....	5-12
5.3.2 <i>Automatic Calibration (AutoCal)</i> .....	5-12
5.3.3 <i>Data Acquisition System (DAS)</i> .....	5-12
5.3.4 <i>Range Menu</i> .....	5-13
5.3.5 <i>Password Enable</i> .....	5-17
5.3.6 <i>Time of Day Clock</i> .....	5-17
5.3.7 <i>Diagnostic Mode</i> .....	5-17
5.3.8 <i>Communications Menu</i> .....	5-17
5.3.9 <i>Variables Menu (VARs)</i> .....	5-18
<b>6 OPTIONAL HARDWARE AND SOFTWARE</b> .....	<b>6-1</b>

6.1 RACK MOUNT OPTIONS .....	6-1
6.2 ZERO/SPAN VALVES .....	6-1
6.3 INTERNAL ZERO/SPAN (IZS).....	6-3
6.4 AUTOCAL - SETUP OF IZS AND ZERO/SPAN VALVES .....	6-3
6.5 PERMEATION TUBE (USED WITH IZS OPTION) .....	6-6
6.6 4-20 mA, CURRENT LOOP OUTPUT .....	6-9
6.7 STATUS OUTPUT .....	6-9
6.8 RS-232 INTERFACE.....	6-10
6.8.1 <i>Setting Up the RS-232 Interface</i> .....	6-10
6.8.2 <i>Command Summary</i> .....	6-13
6.8.3 <i>TEST Commands and Messages</i> .....	6-17
6.8.4 <i>WARNING Commands And Messages</i> .....	6-18
6.8.5 <i>CALIBRATION Commands and Messages</i> .....	6-19
6.8.6 <i>DIAGNOSTIC Commands and Messages</i> .....	6-20
6.8.7 <i>DAS Commands and Reports</i> .....	6-21
6.8.8 <i>VARIABLES Commands and Messages</i> .....	6-24
<b>7 CALIBRATION AND ZERO/SPAN CHECKS .....</b>	<b>7-1</b>
7.1 MANUAL ZERO/SPAN CHECK OR CALIBRATION THROUGH THE SAMPLE PORT .....	7-4
7.2 MANUAL ZERO/SPAN CHECK OR CALIBRATION WITH ZERO/SPAN VALVES OPTION .....	7-6
7.3 MANUAL ZERO/SPAN CHECK WITH IZS OPTION .....	7-7
7.4 AUTOMATIC ZERO/SPAN CHECK .....	7-7
7.5 AUTOMATIC ZERO/SPAN CALIBRATION .....	7-7
7.6 CALIBRATE ON SO <sub>2</sub> PERMEATION TUBE.....	7-8
7.7 USE OF IZS OR ZERO/SPAN VALVES WITH REMOTE CONTACT CLOSURE.....	7-8
7.8 EPA PROTOCOL CALIBRATION .....	7-9
7.8.1 <i>Calibration of Equipment</i> .....	7-9
7.8.2 <i>Calibration Gas Sources</i> .....	7-10
7.8.3 <i>Data Recording Device</i> .....	7-12
7.8.4 <i>Dynamic Multipoint Span Calibration</i> .....	7-12
7.8.5 <i>SO<sub>2</sub> Calibration Procedure</i> .....	7-13
7.8.6 <i>Calibration Frequency</i> .....	7-19
7.8.7 <i>Other Quality Assurance Procedures</i> .....	7-19
7.8.8 <i>Summary of Quality Assurance Checks</i> .....	7-21
7.8.9 <i>ZERO and SPAN Checks</i> .....	7-22
7.8.10 <i>Recommended Standards for Establishing Traceability</i> .....	7-23
7.9 SPECIAL CALIBRATION REQUIREMENTS FOR DUAL RANGE OR AUTO RANGE.....	7-24
7.10 CALIBRATION QUALITY .....	7-25
7.11 REFERENCES .....	7-26
<b>8 MAINTENANCE .....</b>	<b>8-1</b>
8.1 MAINTENANCE SCHEDULE .....	8-1
8.2 REPLACING THE SAMPLE PARTICULATE FILTER .....	8-2
8.3 REPLACING THE PERMEATION TUBE (OPTION).....	8-4
8.4 REPLACING THE IZS ZERO AIR SCRUBBER (OPTION) .....	8-4
8.5 CLEANING ORIFICE AND ORIFICE FILTER .....	8-5

8.6 CLEANING THE REACTION CELL ..... 8-6  
 8.7 PNEUMATIC LINE INSPECTION ..... 8-6  
 8.8 LEAK CHECK PROCEDURE ..... 8-9  
 8.9 LIGHT LEAK CHECK PROCEDURE ..... 8-10  
 8.10 EPROM REPLACEMENT PROCEDURE ..... 8-10

**9 DIAGNOSTIC, TROUBLESHOOTING ..... 9-1**

9.1 OPERATION VERIFICATION - M100A DIAGNOSTIC TECHNIQUES ..... 9-3  
     9.1.1 *Fault Diagnosis with TEST Variables* ..... 9-3  
     9.1.2 *Fault Diagnosis with WARNING Messages* ..... 9-9  
     9.1.3 *Fault Diagnosis using DIAGNOSTIC Mode* ..... 9-11  
     9.1.4 *M100A Internal Variables* ..... 9-18  
     9.1.5 *Test Channel Analog Output* ..... 9-20  
     9.1.6 *Factory Calibration Procedure (Quick Cal)* ..... 9-21  
 9.2 PERFORMANCE PROBLEMS ..... 9-23  
     9.2.1 *AC Power Check* ..... 9-23  
     9.2.2 *Flow Check* ..... 9-24  
     9.2.3 *No Response to Sample Gas* ..... 9-24  
     9.2.4 *Negative Concentration Display* ..... 9-25  
     9.2.5 *Excessive Noise* ..... 9-25  
     9.2.6 *Unstable Span* ..... 9-26  
     9.2.7 *Unstable Zero* ..... 9-27  
     9.2.8 *Inability to Span* ..... 9-27  
     9.2.9 *Inability to Zero* ..... 9-28  
     9.2.10 *Non-Linear Response* ..... 9-28  
     9.2.11 *Slow Response* ..... 9-29  
     9.2.12 *Analog Output Doesn't Agree With Display Concentration* ..... 9-29  
 9.3 ELECTRONIC SUBSYSTEM TROUBLESHOOTING AND ADJUSTMENTS ..... 9-30  
     9.3.1 *Computer, Display, Keyboard* ..... 9-30  
     9.3.2 *RS-232 Communications* ..... 9-33  
     9.3.3 *Voltage/Frequency (V/F) Board* ..... 9-36  
     9.3.4 *Status/Temp Board* ..... 9-42  
     9.3.5 *Power Supply Module* ..... 9-45  
     9.3.6 *Flow/Pressure Sensor* ..... 9-49  
     9.3.7 *Reaction Cell Temp* ..... 9-53  
     9.3.8 *Preamp Board* ..... 9-53  
     9.3.9 *PMT Cooler* ..... 9-53  
     9.3.10 *HVPS (High Voltage Power Supply)* ..... 9-56  
 9.4 OPTICAL SENSOR MODULE TROUBLESHOOTING ..... 9-58  
     9.4.1 *PMT* ..... 9-58  
     9.4.2 *UV Lamp Adjust or Replacement* ..... 9-58  
     9.4.3 *UV Filter Replacement* ..... 9-59  
     9.4.4 *Shutter System* ..... 9-59  
 9.5 PNEUMATIC SYSTEM TROUBLESHOOTING ..... 9-60  
     9.5.1 *Leak Check* ..... 9-60  
     9.5.2 *Pump* ..... 9-60  
     9.5.3 *Kicker* ..... 9-60

9.5.4 Z/S Valves & IZS Permeation Tube Oven ..... 9-62

**10 TELEDYNE API M100A SPARE PARTS LIST ..... 10-1**

**APPENDIX A MAINTENANCE SCHEDULE FOR M100A..... A-1**

**APPENDIX B ELECTRICAL SCHEMATICS ..... B-1**

## List of Figures

FIGURE 2-1: REMOVAL OF SHIPPING SCREWS.....	2-3
FIGURE 2-2: REAR PANEL .....	2-4
FIGURE 2-3: REAR PANEL PNEUMATIC RECOMMENDATIONS.....	2-5
FIGURE 2-4: FRONT PANEL .....	2-10
FIGURE 2-5: ASSEMBLY LAYOUT .....	2-11
FIGURE 4-1: M100A SULFUR DIOXIDE ANALYZER .....	4-3
FIGURE 4-2: FRONT PANEL DISPLAY .....	4-7
FIGURE 5-1: SAMPLE MENU .....	5-1
FIGURE 5-2: SETUP MENU TREE.....	5-2
FIGURE 6-1: PERMEATION TUBE INSTALLATION .....	6-8
FIGURE 7-1: MODEL 100A CALIBRATION SETUP.....	7-3
FIGURE 7-2: DIAGRAM OF CALIBRATION SYSTEM .....	7-15
FIGURE 7-3: DIAGRAM F PERMEATION CALIBRATION SYSTEM.....	7-17
FIGURE 8-1: REPLACING THE PARTICULATE FILTER .....	8-3
FIGURE 8-2: REACTION CELL.....	8-7
FIGURE 8-3: PNEUMATIC DIAGRAM.....	8-8
FIGURE 9-1: CPU BOARD JUMPER SETTINGS .....	9-32
FIGURE 9-2: RS-232 PIN ASSIGNMENTS .....	9-34
FIGURE 9-3: V/F BOARD DIP SWITCH SETTINGS .....	9-41
FIGURE 9-4: POWER SUPPLY MODULE LAYOUT.....	9-46
FIGURE 9-5: ELECTRICAL BLOCK DIAGRAM.....	9-47
FIGURE 9-6: FLOW/PRESSURE SENSOR .....	9-50
FIGURE 9-7: SO <sub>2</sub> SENSOR MODULE .....	9-51
FIGURE 9-8: SO <sub>2</sub> SENSOR MODULE .....	9-52
FIGURE 9-9: PMT COOLER SUBSYSTEM.....	9-55
FIGURE 9-10: HIGH VOLTAGE POWER SUPPLY.....	9-57
FIGURE 9-11: KICKER LEAK CHECK.....	9-61

## List of Tables

TABLE 2-1: FINAL TEST AND CALIBRATION VALUES.....	2-12
TABLE 2-1: FINAL TEST AND CALIBRATION VALUES (CONTINUED) .....	2-13
TABLE 4-1: SYSTEM MODES DISPLAY .....	4-6
TABLE 4-2: FRONT PANEL STATUS LED'S .....	4-7
TABLE 5-1: M100A SAMPLE MENU STRUCTURE .....	5-3
TABLE 5-2: M100A SETUP MENU STRUCTURE .....	5-4
TABLE 5-3: M100A MENU STRUCTURE - SETUP MENU #2 .....	5-5
TABLE 5-4: M100A MENU STRUCTURE - SETUP MENU #3 .....	5-6
TABLE 5-5: CALIBRATE, SETUP PASSWORDS .....	5-17
TABLE 6-1: ZERO/SPAN VALVE OPERATION .....	6-2
TABLE 6-2: SETUP AUTOMATIC ZERO/SPAN CALIBRATION.....	6-4
TABLE 6-3: STATUS OUTPUT PIN ASSIGNMENTS .....	6-9
TABLE 6-4: RS-232 PORT SETUP - FRONT PANEL.....	6-11
TABLE 6-5: RS-232 SWITCHING FROM TERMINAL MODE TO COMPUTER MODE .....	6-12
TABLE 6-6: RS-232 TERMINAL MODE EDITING KEYS .....	6-13
TABLE 6-7: RS-232 COMMAND SUMMARY .....	6-14
TABLE 6-8: RS-232 COMMAND SUMMARY .....	6-15
TABLE 6-9: RS-232 INTERFACE COMMAND TYPES .....	6-16
TABLE 6-10: RS-232 TEST MESSAGES .....	6-17
TABLE 6-11: RS-232 WARNING MESSAGES .....	6-18
TABLE 6-12: RS-232 CALIBRATION MESSAGES .....	6-19
TABLE 6-13: RS-232 CALIBRATION COMMANDS.....	6-20
TABLE 6-14: RS-232 DIAGNOSTIC COMMAND SUMMARY .....	6-21
TABLE 6-15: RS-232 DAS COMMANDS.....	6-21
TABLE 6-16: RS-232 OPERATING MODES .....	6-24
TABLE 7-1: TYPES OF ZERO/SPAN CHECKS AND CALIBRATIONS .....	7-2
TABLE 7-2: MANUAL ZERO CALIBRATION PROCEDURE - ZERO GAS THROUGH SAMPLE PORT.....	7-4
TABLE 7-3: ENTER EXPECTED SPAN GAS CONCENTRATIONS PROCEDURE .....	7-5
TABLE 7-4: MANUAL SPAN CALIBRATION PROCEDURE - SPAN GAS THROUGH SAMPLE PORT.....	7-5
TABLE 7-5: MANUAL ZERO CALIBRATION PROCEDURE - Z/S VALVES .....	7-6
TABLE 7-6: MANUAL SPAN CALIBRATION PROCEDURE - Z/S VALVES.....	7-6
TABLE 7-7: IZS OR Z/S VALVES MODES WITH REMOTE CONTACT CLOSURE.....	7-9
TABLE 7-8: ACTIVITY MATRIX FOR CALIBRATION EQUIPMENT & SUPPLIES .....	7-11
TABLE 7-9: ACTIVITY MATRIX FOR CALIBRATION PROCEDURE .....	7-12
TABLE 7-10: EPA ZERO CALIBRATION PROCEDURE .....	7-14
TABLE 7-11: EPA EXPECTED SPAN GAS CONCENTRATION PROCEDURE.....	7-15
TABLE 7-12: EPA SPAN CALIBRATION PROCEDURE .....	7-16
TABLE 7-13: DEFINITION OF LEVEL 1 AND LEVEL 2 ZERO AND SPAN CHECKS .....	7-20
TABLE 7-14: ACTIVITY MATRIX.....	7-21
TABLE 7-15: NIST-SRM'S AVAILABLE FOR TRACEABILITY OF CALIBRATION AND AUDIT GAS STANDARDS .....	7-24
TABLE 7-16: CALIBRATION QUALITY CHECK.....	7-25

TABLE 8-1: PREVENTATIVE MAINTENANCE SCHEDULE .....	8-1
TABLE 9-1: TEST FUNCTIONS.....	9-3
TABLE 9-1: TEST FUNCTIONS (CONTINUED) .....	9-4
TABLE 9-1: TEST FUNCTIONS (CONTINUED) .....	9-5
TABLE 9-1: TEST FUNCTIONS (CONTINUED) .....	9-6
TABLE 9-1: TEST FUNCTIONS (CONTINUED) .....	9-7
TABLE 9-1: TEST FUNCTIONS (CONTINUED) .....	9-8
TABLE 9-2: FRONT PANEL WARNING MESSAGES.....	9-9
TABLE 9-2: FRONT PANEL WARNING MESSAGES (CONTINUED) .....	9-10
TABLE 9-3: SUMMARY OF DIAGNOSTIC MODES.....	9-12
TABLE 9-4: DIAGNOSTIC MODE - SIGNAL I/O.....	9-13
TABLE 9-5: MODEL 100A VARIABLES .....	9-19
TABLE 9-6: TEST CHANNEL OUTPUT .....	9-20
TABLE 9-7: POWER SUPPLY MODULE SUBASSEMBLIES .....	9-45
TABLE 9-8: POWER SUPPLY MODULE LED OPERATION .....	9-48
TABLE 10-1: TELEDYNE API M100A SPARE PARTS LIST .....	10-1
TABLE 10-1: TELEDYNE API M100A SPARE PARTS LIST (CONTINUED).....	10-2
TABLE 10-1: TELEDYNE API M100A SPARE PARTS LIST (CONTINUED).....	10-3
TABLE 10-1: TELEDYNE API M100A SPARE PARTS LIST (CONTINUED).....	10-4
TABLE 10-2: TELEDYNE API M100A LEVEL 1 SPARES KIT.....	10-4
TABLE 10-3: TELEDYNE API M100A 37 MM EXPENDABLES KIT .....	10-5
TABLE 10-4: TELEDYNE API M100A 47 MM EXPENDABLES KIT .....	10-5
TABLE 10-5: TELEDYNE API M100A EXPENDABLES KIT - IZS .....	10-6
TABLE 10-6: TELEDYNE API M100A SPARES KIT FOR 1 UNIT.....	10-6



# 1 HOW TO USE THIS MANUAL

The Model 100A has been designed with serviceability, reliability and ease of operation in mind. The M100A's microprocessor continually checks operating parameters such as temperature, flow, and critical voltages. The instruments modular design uses captive screws to facilitate repair and ease of access. If you encounter any difficulty refer to Section 9 General Troubleshooting Hints.

We recognize that the need for information in this manual changes as time passes. When the instrument first arrives, it is necessary to get it up and running quickly and verify its correct operation. As time passes, more detailed information is often required on special configurations, calibration alternatives and other operational details. Finally there is the need for periodic maintenance and to quickly troubleshoot problems to assure maximum uptime and data integrity.

To address these needs, we have created three indexes to the information inside. They are:

## Table of Contents:

Outlines the contents of the manual in the order the information is presented. This is a good overview of the topics covered in the manual. There is also a list of Tables and a list of Figures.

## Index to M100A Front Panel Menus:

The Menu Index (Figure 5-1 and Figure 5-2, and Table 5-2) briefly describes the front panel menus and refers you to other sections of the manual that have a detailed explanation of each menu selection.

## Troubleshooting Section 9

The Troubleshooting Section, outlined in the Table of contents, allows you to diagnose and repair the instrument based on variables in the TEST menu, the results of DIAGNOSTIC tests, and performance faults such as excessive noise or drift. The troubleshooting section also explains the operation, adjustment, diagnosis and testing of each instrument subsystem.

**If you are unpacking the instrument for the first time, please refer to Getting Started in Section 2.**

## 1.1 Safety Messages

Your safety and the safety of others is very important. We have provided many important safety messages in this manual. Please read these messages carefully.

A safety message alerts you to potential hazards that could hurt you or others. Each safety message is associated with a safety alert symbol. These symbols are found in the manual and inside the instrument. The definition of these symbols is described below:



GENERAL WARNING/CAUTION: Refer to the instructions for details on the specific danger.



CAUTION: Hot Surface Warning



CAUTION: Electrical Shock Hazard



Technician Symbol: All operations marked with this symbol are to be performed by qualified maintenance personnel only.

### CAUTION

**The analyzer should only be used for the purpose and in the manner described in this manual.**

**If you use the analyzer in a manner other than that for which it was intended, unpredictable behavior could ensue with possibly hazardous consequences.**



## 2 GETTING STARTED

### 2.1 Installation

**CAUTION**

**To avoid personal injury, always use two persons to lift and carry the Model 100A.**



8. Verify that there is no apparent shipping damage. If damage has occurred please advise shipper first, then Teledyne API.
  1. Before operation it is necessary to remove the shipping hold-down screws. Remove the instrument cover, then refer to Figure 2-1 for screw location.

Note:  
Save the shipping screws and re-install them whenever the unit is shipped to another location.
  2. While the instrument cover is removed, please check the voltage and frequency label on the cover of the power supply module and compare that to your local power before plugging in the M100A.
9. Check for internal shipping damage, and generally inspect the interior of the instrument to make sure all circuit boards and other components are in good shape.
  3. Replace the instrument cover.
  4. When installing the M100A, allow at least 4” (10 cm) clearance at the back and at least 1” (2.5 cm) clearance at each side for proper venting.

### 2.2 Electrical and Pneumatic Connections

10. Refer to Figure 2-2 to locate the rear panel electrical and pneumatic connections.
11. The pressure of the sample gas at the inlet port should be at atmospheric pressure (Refer to Figure 2-3 and Figure 7-1 for pneumatic system connection).
  1. Connect the analyzer exhaust to a suitable vent at atmospheric pressure. (See Figure 2-3 for exhaust line venting recommendations.)

2. If desired, attach the analog output connections to a strip chart recorder and/or datalogger. Refer to Figure 9-3 for jumper settings for the desired analog output voltage range. Factory default setting is 0-5VDC.
3. Connect the power cord to the correct voltage line, then turn to Section 2.3 Initial Operation.

**CAUTION**

**High voltages present inside case.**

**DO NOT LOOK AT THE UV LAMP, UV LIGHT  
COULD CAUSE EYE DAMAGE.**

**ALWAYS USE SAFETY GLASSES  
(PLASTIC GLASSES WILL NOT DO).**

**Connect the exhaust fitting on the rear panel to a  
suitable vent outside of the room.**



**CAUTION**

**DO NOT OPERATE WITH COVER OFF.**

**Before operation check for correct line voltage and  
frequency on Serial Number Sticker.**

**Do not plug in the power cord if the voltage or  
frequency is incorrect.**

**Do not operate without proper chassis grounding.**

**Do not defeat the ground wire on power plug.**

**Turn off analyzer power before disconnecting or  
connecting electrical subassemblies.**

**Always replace shipping screws when transporting the Analyzer.**



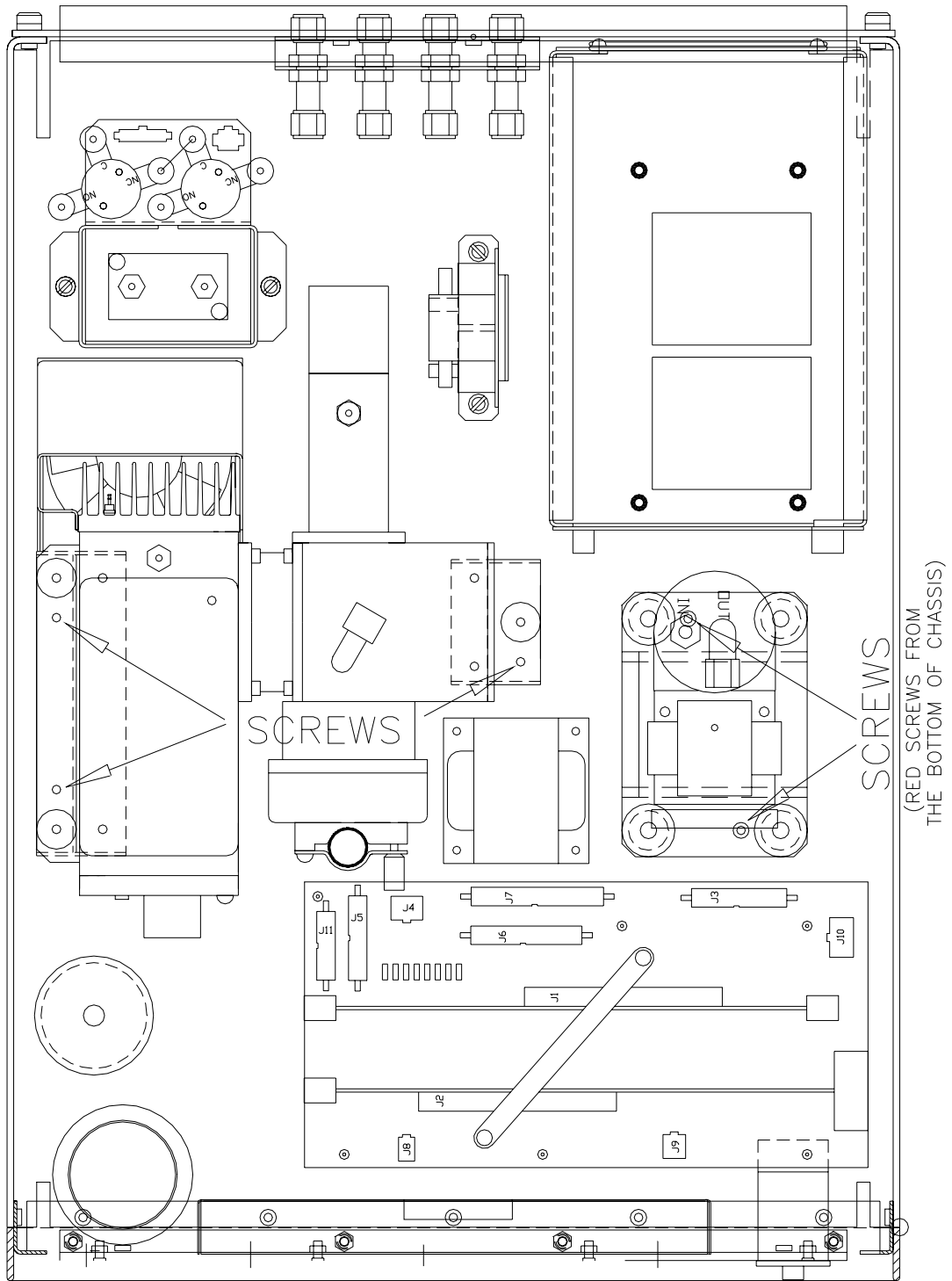

**Figure 2-1: Removal of Shipping Screws**

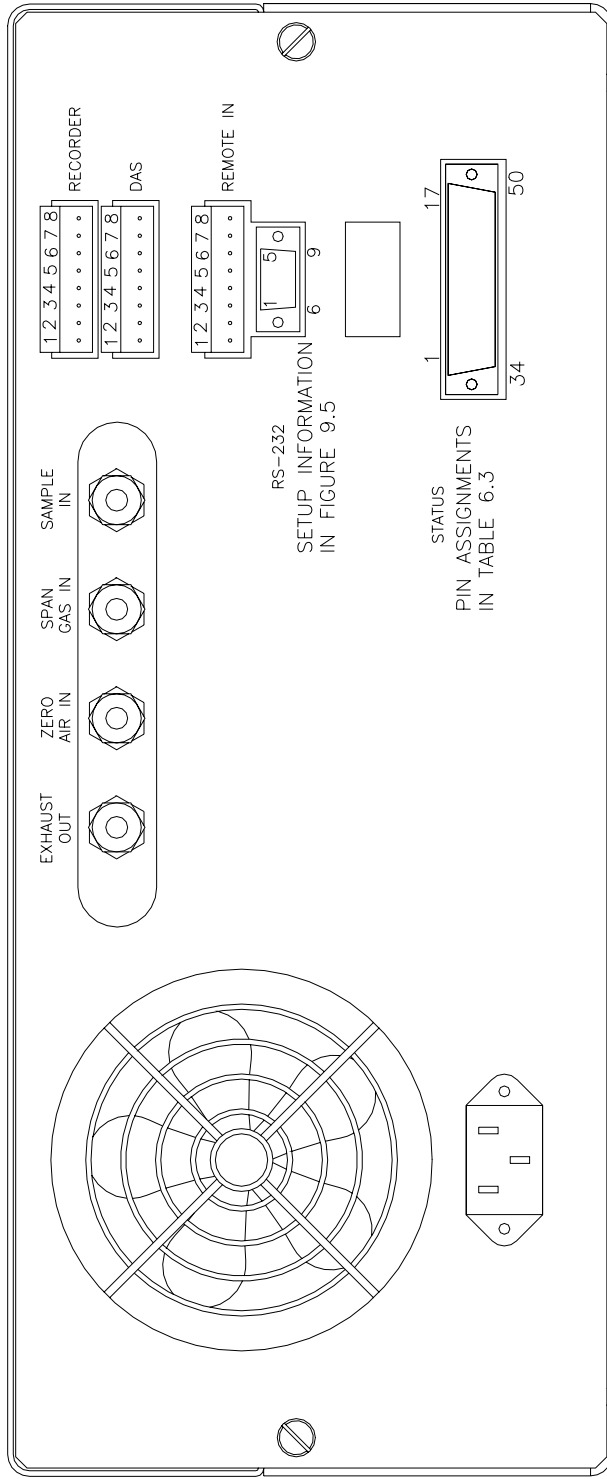

RS-232  
SETUP INFORMATION  
IN FIGURE 9.5

STATUS  
PIN ASSIGNMENTS  
IN TABLE 6.3

RECORDER AND DAS  
PIN ASSIGNMENTS

PIN NO.	ASSIGNMENT
1	+ SO <sub>2</sub> (RANGE1)
2	- SO <sub>2</sub> (RANGE1)
3	+ SO <sub>2</sub> (RANGE2)
4	- SO <sub>2</sub> (RANGE2)
5	
6	
7	+ TEST CHANNEL
8	- TEST CHANNEL

REMOTE IN  
PIN ASSIGNMENTS

PIN NO.	ASSIGNMENT
1	+ REM ZERO CAL
2	- REM ZERO CAL
3	+ REM SPAN CAL
4	- REM SPAN CAL
5	
6	
7	
8	

RS-232 PORT  
PIN ASSIGNMENTS

PIN NO.	ASSIGNMENT
1	
2	*TX(RX) DATA
3	*RS(TX) DATA
4	
5	SIG GROUND
6	DSR
7	
8	CTS
9	

\*Jumpers set inter-changeable

Figure 2-2: Rear Panel

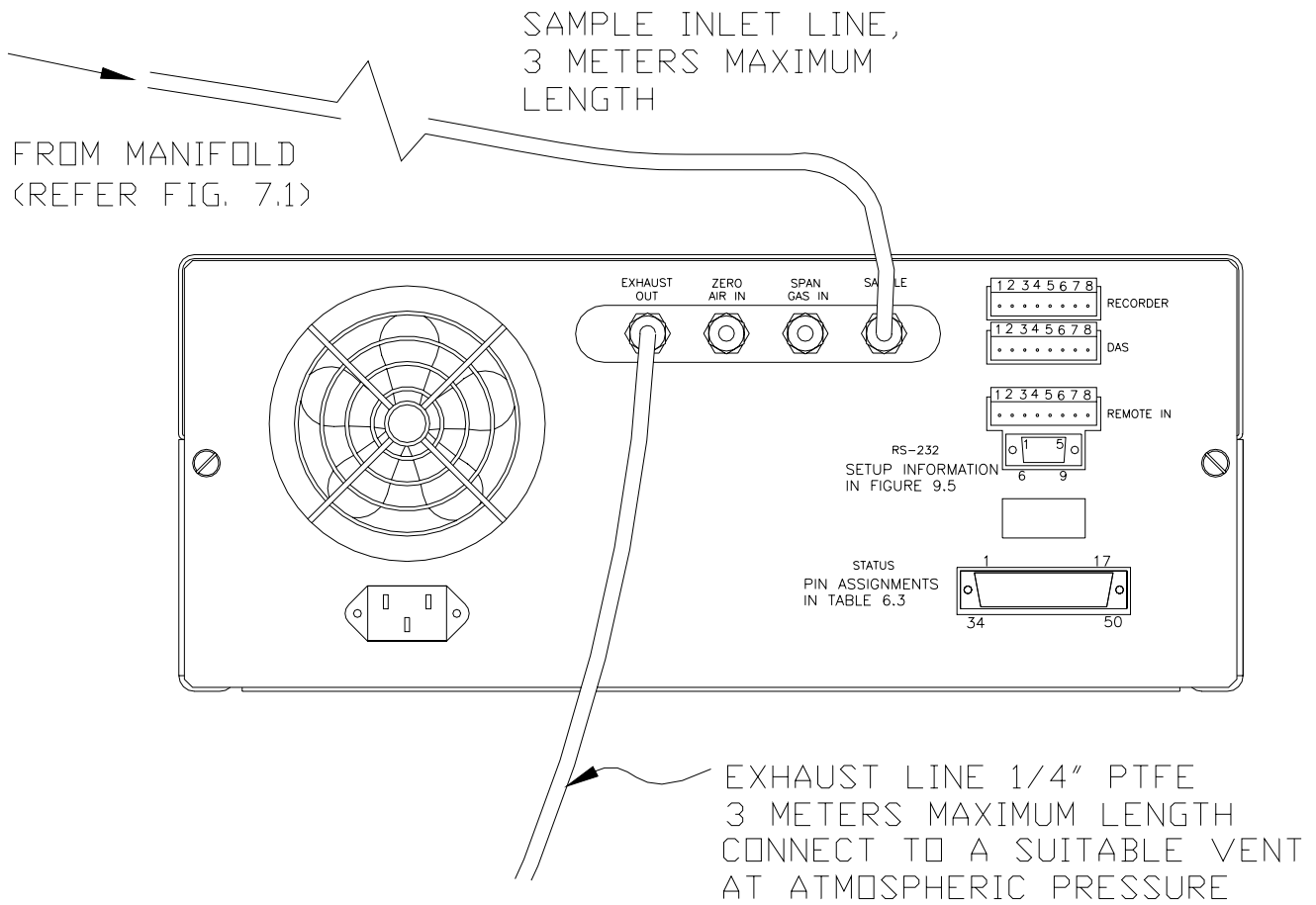

NOTE:

TUBING/FITTING MATERIAL 1/4" PTFE  
OR GLASS ONLY.

**Figure 2-3: Rear Panel Pneumatic Recommendations**

## 2.3 Initial Operation

12. Turn on the instrument power.
  1. The display should immediately light, displaying the instrument type (M100A) and the CPU memory configuration. If you are unfamiliar with the M100A, we recommend that you read the overview Section 4 before proceeding. A diagram of the software menu trees is in Figure 5-1 and Figure 5-2.
13. The M100A requires about 60 minutes for all internal components to come up to temperature.
  2. While waiting for instrument temperatures to come up, you can check for correct operation by using some of the M100A's diagnostic and test features.
  3. Examine the TEST functions by comparing the values listed in Table 2-1 to those in the display. Remember that as the instrument warms up the values may change until they reach their final values. If you would like to know more about the meaning and utility of each TEST function refer to Table 9-1. Table 2-1 also contains the list of options. Section 6 covers setting up the options.
  4. When the instrument is warmed up, re-check the TEST functions against Table 2-1. All of the readings should compare closely with those in the Table. If they do not, see Section 9.1.1.

**NOTE**

**Do not calibrate the analyzer within 60 minutes after the power reset.**

The next task is to calibrate the analyzer. There are several ways to do a calibration; they are summarized in Table 7-1. For a preliminary checkout we recommend calibration with zero air and span gas coming in through the sample port. The procedure is:

Step 1 - Enter the expected SO<sub>2</sub> span gas concentration

<b>Step Number</b>	<b>Action</b>	<b>Comment</b>
1.	Press CAL-CONC	This key sequence causes the M100A to prompt for the expected SO <sub>2</sub> concentration. Enter the SO <sub>2</sub> span concentration value by pressing the key under each digit until the expected value is set.
2.	Press ENTR	ENTR stores the expected SO <sub>2</sub> span value. This value will be used in the internal formulas to compute subsequent SO <sub>2</sub> concentration values.
3.	Press EXIT	Returns instrument to SAMPLE mode.
4.	Press SETUP-RNGE-SET	If necessary you may want to change ranges. Normally the instrument is shipped with range set at 500 ppb.
5.	Press EXIT	Returns the instrument to SAMPLE mode.

Step 2 - Calibrate the instrument:

**Zero/Span Calibration Procedure**

<b>Step Number</b>	<b>Action</b>	<b>Comment</b>
1.	Input Zero gas	Allow Zero gas to enter the sample port on the rear of the instrument.
2.	Press CAL	The M100A enters the calibrate mode from sample mode.
3.	Wait 10 min	Wait for reading to stabilize at the zero value. (If you wait less than 10 minutes the final zero value may drift.)
4.	Press ZERO	The ZERO button will be displayed.
5.	Press ENTR	Pressing ENTR actually changes the calculation equations and zeroes the instrument.
6.	Press EXIT	M100A returns to the CAL menu. Now switch gas streams to span gas.
7.	Wait 10 min	Wait for reading to stabilize at the span value. (If you wait less than 10 minutes the final span value may drift.)
8.	Press SPAN	The SPAN button should be displayed. If it is not, check the Troubleshooting Section 9.2.8 for instructions on how to proceed. In certain circumstances at low span gas concentrations (<100ppb), both the ZERO and SPAN buttons will appear.
9.	Press ENTR	Pressing ENTR actually changes the calculation equations so that the concentration displayed is the same as the expected span concentration you entered above, thus spanning the instrument.
10.	Press EXIT	Pressing EXIT returns the instrument to SAMPLE mode.

Step 3 - Review the quality of the calibration:

**Calibration Quality Check Procedure**

<b>Step Number</b>	<b>Action</b>	<b>Comment</b>
1.	Scroll the TEST function menu until the SO <sub>2</sub> SLOPE is displayed.	Typical SLOPE value is 1.0 +/- 0.3. If the value is not in this range, check Section 7.10 or 9. If the SLOPE value is in the acceptable range the instrument will perform optimally.
2.	Scroll the TEST function menu until the SO <sub>2</sub> OFFSET is displayed.	The M100A will display the OFFSET parameter for the SO <sub>2</sub> equation. A value between 50mV to 250mV indicates calibration in the optimal range. If the OFFSET value is outside this range, check Section 7.10 and 9.

Step 4 - The M100A is now ready to measure sample gas.

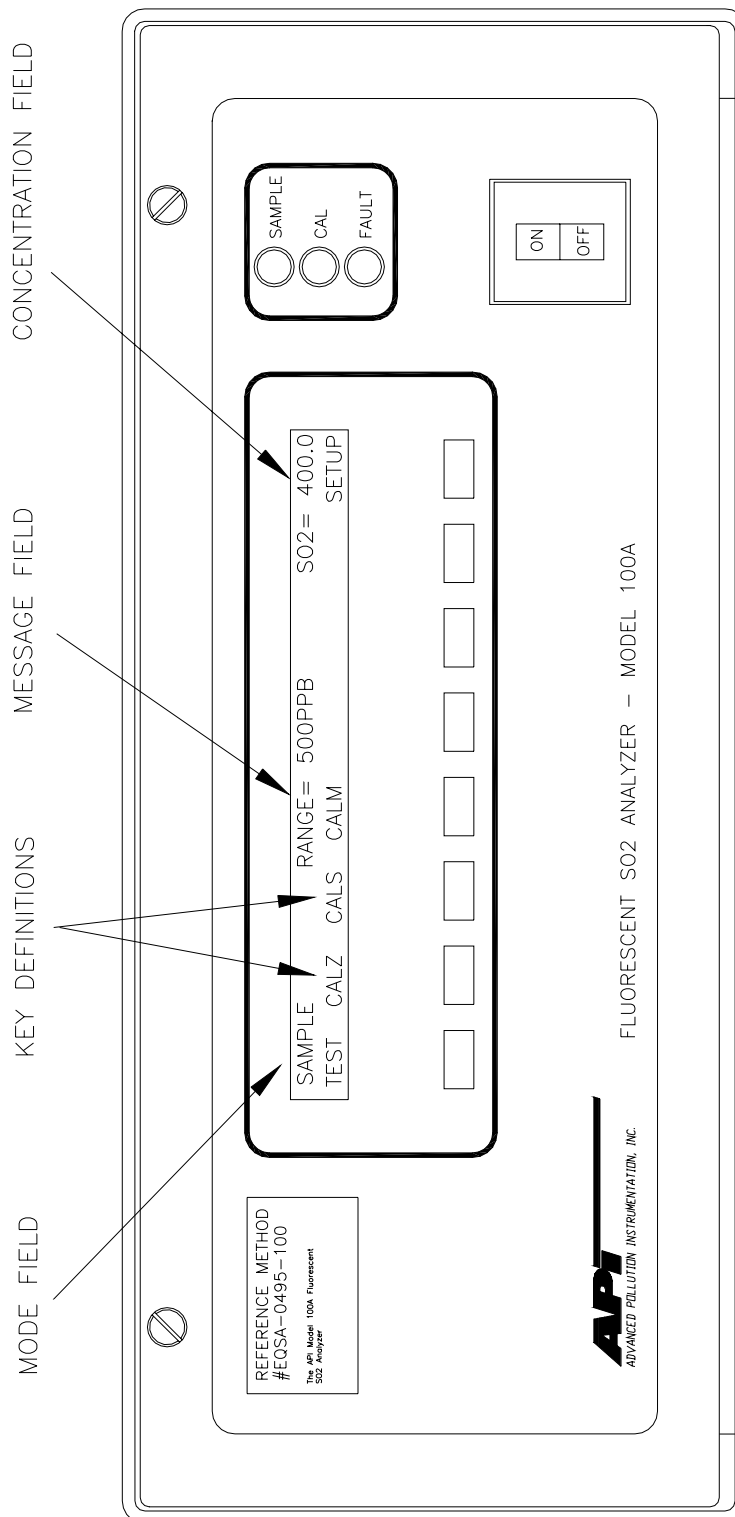

Figure 2-4: Front Panel

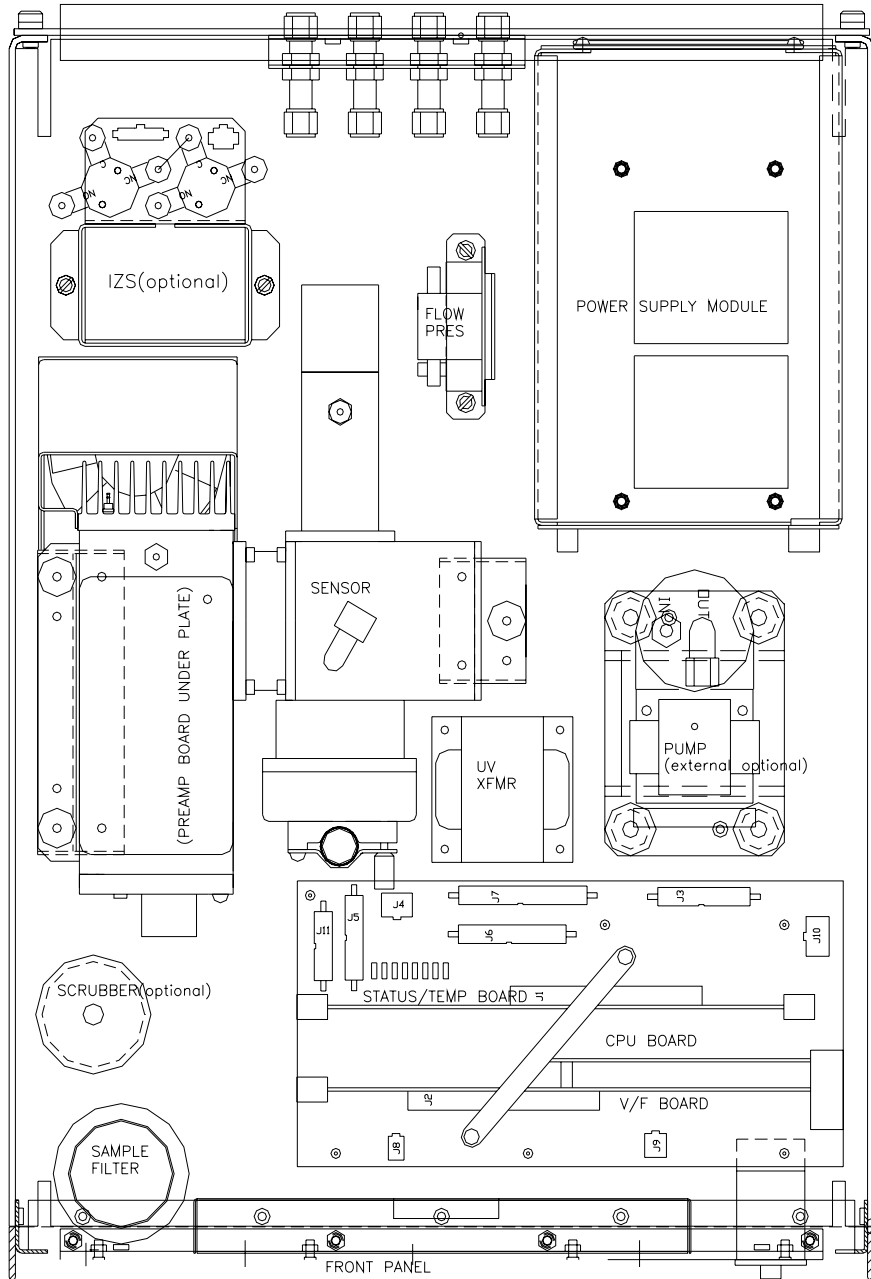

Figure 2-5: Assembly Layout

**Table 2-1: Final Test and Calibration Values**

TEST Values	Observed Value	Units	Nominal Range	Reference Section
RANGE		PPB	50 - 20,000	5.3.4
STABIL		PPB	0.1 - 2	5.2.1, 9.1.1, Table 9-1, 9.2.5
PRESS		in-Hg	25 - 35	9.1.1, 9.3.6, Table 9-1
SAMP FL		CC / MIN	650 ± 10%	9.2.2, 9.3.6, Table 9-1
PMT		mV	0 - 5000	9.4.1
UV LAMP		mV	2000 - 4000 typical	9.4.2
STR. LGT		PPB	<100	Table 9-1
DRK PMT		mV	-50 - +200	9.4.3, Table 9-1
DRK LMP		mV	-50 - +200	Table 9-1
SLOPE			1.0 ± 0.3	7.10
OFFSET		mV	<250	7.10
HVPS		V	550 - 900 constant	9.3.10
DCPS		mV	2500 ± 200	9.3.5
RCELL TEMP		°C	50 ± 1	9.3.7
BOX TEMP		°C	8-50	9.3.4.1
PMT TEMP		°C	7 ± 1	9.3.9
IZS TEMP		°C	50 ± 0.3	9.5.4
<b>Electric Test &amp; Optic Test</b>				
<b>Electric Test</b>				
PMT Volts		mV	2000 ± 1000	9.1.3.2
SO <sub>2</sub> Conc		PPB	1000 ± 500	9.1.3.2
		Optic Test		
PMT Volts		mV	2000 ± 1000	9.1.3.3
SO <sub>2</sub> Conc		PPB	1000 ± 500	9.1.3.3

*(table continued)*

**Table 2-1: Final Test and Calibration Values (Continued)**

Span and Cal Values				
Parameter	Observed Value	Units	Nominal Range	Reference Section
SO <sub>2</sub> Span Conc		PPB	20 - 20,000	Table 7-3
SO <sub>2</sub> Slope			1.0 ± 0.3	7.10
SO <sub>2</sub> Offset		mV	<250	7.10
Noise at Zero (rms)		PPB	0.1 - 0.2	Table 9-1
Noise at Span (rms)		PPB	0.5% of reading (above 50 ppb)	Table 9-1
Measured Flows				
Parameter	Observed Value	Units	Nominal Range	Reference Section
Sample Flow		cc/min	650 ± 10%	9.2.2, 9.3.6, Figure 9-6
IZS Purge Flow		cc/min	50 ± 10	6.3
Factory Installed Options			Option Installed	
Power Voltage/Frequency				
Rack Mount, w/ Slides				
Rack Mount, w/ Ears Only				
Fluorocarbon Zero/Span Valves				
Internal Zero/Span - IZS				
Permeation Tube (Output Specification)				
External Pump				
4-20 mA Current Loop Output				
	REC	DAS		
	SO <sub>2</sub> (RANGE 1)			
	SO <sub>2</sub> (RANGE 2)			
	SPARE			
	TEST OUTPUT			

PROM # \_\_\_\_\_

Date \_\_\_\_\_

Serial # \_\_\_\_\_

Technician \_\_\_\_\_

INTENTIONALLY BLANK

## 3 SPECIFICATIONS, AGENCY APPROVALS, WARRANTY

### 3.1 Specifications

Ranges	In 1ppb increments from 50ppb to 20,000ppb, dual ranges or autoranging
Noise at Zero <sup>1</sup>	0.2 ppb RMS
Noise at Span <sup>1</sup>	<0.5% of reading (above 50 ppb)
Lower Detectable Limit <sup>2</sup>	0.4 ppb RMS
Zero Drift <sup>3</sup>	<0.5 ppb/24 hours
Zero Drift <sup>3</sup>	1 ppb/7 days
Span Drift <sup>3</sup>	<0.5% FS/7 days
Lag Time	20 sec
Rise Time	95% in <100 sec
Fall Time	95% in <100 sec
Sample Flow Rate	650cc/min. ±10%
Linearity	1% of full scale
Precision	0.5% of reading <sup>1</sup>
Temperature Range	5-40°C
Temp Coefficient	< 0.1% per °C
Humidity	0 - 95% RH, non-condensing
Voltage Coefficient	< 0.05% per V
Dimensions HxWxD	7"x17" x 23.6" (18cm x 43cm x 61cm)
Weight, Analyzer	45 lbs (20.5 kg) w/internal pump
Power, Analyzer	110v/60Hz, 220v/50Hz, 240v/50Hz, 250 watts
Power, Analyzer <sup>4</sup>	230v/50Hz, 2.5A
Environmental Conditions	Installation Category (Overvoltage Category) II Pollution Degree 2
Recorder Output <sup>5</sup>	0-100 mV, 0-1, 5, 10v ; resolution of 1 part in 1024 of selected voltage or current range
Status Option	12 Status Outputs from opto-isolator
Measurement Units	ppb, ppm, ug/m <sup>3</sup> , mg/m <sup>3</sup>

1. As defined by USEPA.
2. Defined as twice the zero noise level.
3. At constant temperature and voltage.
4. Electrical ratings for CE Mark compliance
5. Bi-polar.

## 3.2 EPA Equivalency Designation

Advanced Pollution Instrumentation, Inc., Model 100A Sulfur Dioxide Analyzer is designated as Reference Method Number EQSA-0495-100 as defined in 40 CFR, Part 53, when operated under the following conditions:

14. Range: Any range from 50 ppb to 1000 ppb.
  1. Ambient temperature range of 5 to 40°C.
  2. Line voltage range of 105-125 VAC, 60Hz.
  3. With 5-micron TFE filter element installed in the internal filter assembly.
  4. Sample flow of 650 +/- 65 cc/min.
  5. Vacuum pump (internal or external) capable of 14"Hg Absolute pressure @ 1 slpm or better.
  6. Software settings:
    - A. Dynamic span OFF
    - B. Dynamic zero ON or OFF
    - C. AutoCal ON or OFF
    - D. Dual range ON or OFF
    - E. Autorange ON or OFF
    - F. Temp/Pressure compensation ON

Under the designation, the Analyzer may be operated with or without the following options:

1. Rack mount with chassis slides (P/N 01469).
  2. Rack mount without slides, ears only (P/N 01470).
  3. Fluorocarbon zero/span valves (P/N 01491).
  4. Internal zero/span (P/N 01441).
  5. SO<sub>2</sub> Permeation tube - uncertified 0.4ppm @ 0.7 lpm (P/N 0150603)
  6. SO<sub>2</sub> Permeation tube - certified 0.4ppm @ 0.7 lpm (P/N 0150604)
  7. SO<sub>2</sub> Permeation tube - certified 0.8ppm @ 0.7 lpm (P/N 0150607)
  8. SO<sub>2</sub> Permeation tube - uncertified 0.8ppm @ 0.7 lpm (P/N 0150608)
  9. Zero air scrubber (P/N 01440).
15. 4-20mA, isolated outputs (P/N 01471-1).

## 3.3 Warranty

### WARRANTY POLICY

Prior to shipment, Teledyne API equipment is thoroughly inspected and tested. Should equipment failure occur, Teledyne API assures its customers that prompt service and support will be available.

### COVERAGE

After the warranty period and throughout the equipment lifetime, Teledyne API stands ready to provide on-site or in-plant service at reasonable rates similar to those of other manufacturers in the industry. All maintenance and the first level of field troubleshooting is to be performed by the customer.

### NON-TELEDYNE API MANUFACTURED EQUIPMENT

Equipment provided but not manufactured by Teledyne API is warranted and will be repaired to the extent and according to the current terms and conditions of the respective equipment manufacturers warranty.

### GENERAL

Teledyne API warrants each Product manufactured by Teledyne API to be free from defects in material and workmanship under normal use and service for a period of one year from the date of delivery. All replacement parts and repairs are warranted for 90 days after the purchase.

If a Product fails to conform to its specifications within the warranty period, Teledyne API shall correct such defect by, in Teledyne API's discretion, repairing or replacing such defective Product or refunding the purchase price of such Product.

The warranties set forth in this section shall be of no force or effect with respect to any Product: (i) that has been altered or subjected to misuse, negligence or accident, or (ii) that has been used in any manner other than in accordance with the instruction provided by Teledyne API or (iii) not properly maintained.

**THE WARRANTIES SET FORTH IN THIS SECTION AND THE REMEDIES THEREFORE ARE EXCLUSIVE AND IN LIEU OF ANY IMPLIED WARRANTIES OF MERCHANTABILITY, FITNESS FOR PARTICULAR PURPOSE OR OTHER WARRANTY OF QUALITY, WHETHER EXPRESSED OR IMPLIED. THE REMEDIES SET FORTH IN THIS SECTION ARE THE EXCLUSIVE REMEDIES FOR BREACH OF ANY WARRANTY CONTAINED HEREIN. TELEDYNE API SHALL NOT BE LIABLE FOR ANY INCIDENTAL OR CONSEQUENTIAL DAMAGES ARISING OUT OF OR RELATED TO THIS AGREEMENT OF TELEDYNE API'S PERFORMANCE HEREUNDER, WHETHER FOR BREACH OF WARRANTY OR OTHERWISE.**

### **TERMS AND CONDITIONS**

All units or components returned to Teledyne API should be properly packed for handling and returned freight prepaid to the nearest designated Service Center. After the repair, the equipment will be returned, freight prepaid.

## 4 THE M100A SO<sub>2</sub> ANALYZER

### 4.1 Principle of Operation

The operation of the Teledyne API Model 100A Analyzer is based upon the well proven technology from the measurement of fluorescence of SO<sub>2</sub> due to absorption of UV energy. Sulfur Dioxide absorbs in the 190 nm - 230 nm region free of quenching by air and relatively free of other interferences. Interferences caused by PNA (poly-nuclear aromatics) are reduced by a "kicker"<sup>1</sup> which removes PNA selectively through a membrane without affecting SO<sub>2</sub> sample gas.

The UV lamp emits ultraviolet radiation which passes through a 214 nm bandpass filter, excites the SO<sub>2</sub> molecules, producing fluorescence which is measured by a PMT with a second UV bandpass filter. The equations describing the above reactions are as follows:

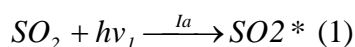

The excitation ultraviolet light at any point in the system is given by:

$$Ia = I_0 [1 - \exp(-ax(SO_2))] \quad (2)$$

Where  $I_0$  is the UV light intensity,  $a$  is the absorption coefficient of SO<sub>2</sub>,  $x$  the path length, and  $(SO_2)$  the concentration of SO<sub>2</sub>. The excited SO<sub>2</sub> decays back to the ground state emitting a characteristic fluorescence:

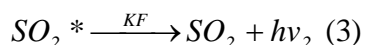

When the SO<sub>2</sub> concentration is relatively low, the path length of exciting light is short and the background is air, the above expression reduces to:

$$F = K(SO_2) \quad (4)$$

Hence, the fluorescent radiation impinging upon the PMT is directly proportional to the concentration of SO<sub>2</sub>.

The block diagram in Figure 4-1 illustrates the general operation principle of the Model 100A.

---

<sup>1</sup>Developed by Dr. Henk, J. Vande Wiel, Laboratory for Inorganic Chemistry, RIVM, National Institute of Public Health and Environmental Protection, Biethoven, The Netherlands.

Ultraviolet light is focused through a narrow 214 nm bandpass filter into the reaction chamber. Here it excites the SO<sub>2</sub> molecules, which give off their characteristic decay radiation. A second filter allows only the decay radiation to fall on the PMT. The PMT transfers the light energy into the electrical signal which is directly proportional to the light energy in the sample stream being analyzed. The preamp board converts this signal into a voltage which is further conditioned by the signal processing electronics.

The UV light source is measured by a UV detector. Software calculates the ratio of the PMT output and the UV detector in order to compensate for variations in the UV light energy. Stray light is the background light produced with zero ppb SO<sub>2</sub>. Once this background light is subtracted, the CPU will convert this electrical signal into the SO<sub>2</sub> concentration which is directly proportional to the number of SO<sub>2</sub> molecules.

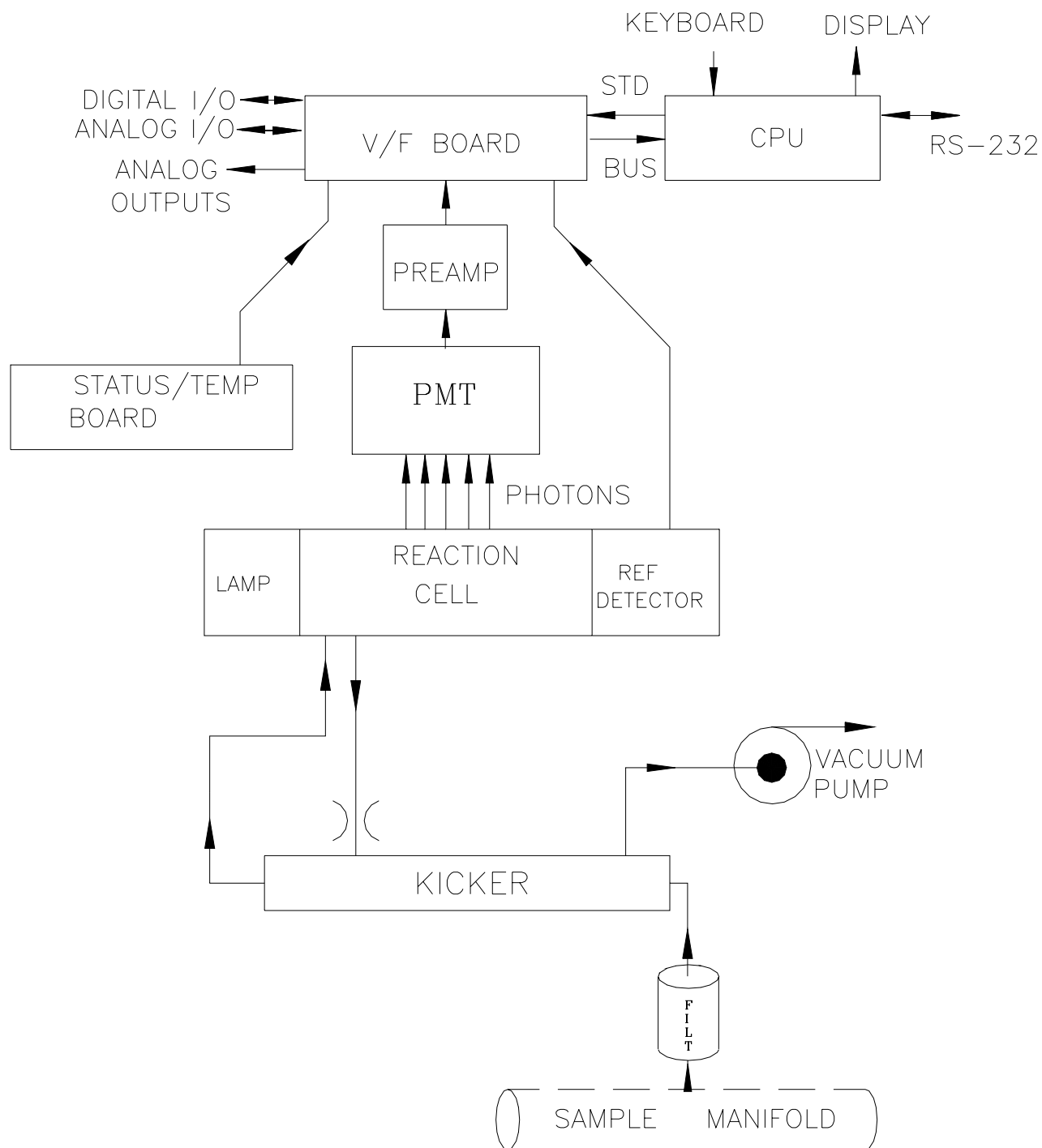

Figure 4-1: M100A Sulfur Dioxide Analyzer

## 4.2 Instrument Description

### 4.2.1 Sensor Module, Reaction Cell, Detector

The sensor module (Figure 9-7) is where the fluorescence light is generated and detected. It is the most complicated and critical sub-assembly in the entire analyzer. It consists of the following assemblies and functions:

1. The reaction cell
2. Reaction cell heater/thermistor
3. PMT and HVPS (high voltage power supply)
4. PMT cooler/cold block/heatsink/fan
5. Preamp assembly:
  - A. Preamp range control hardware
  - B. HVPS control
16. PMT cooler temp control
  - C. Electric and optic test electronics
17. Light trap and UV detector
  6. UV lamp and light shutter

### 4.2.2 Pneumatic Sensor Board

The sensor board consists of a pressure sensor and a flow sensor. The pressure sensor measures the sample pressure at the reaction cell which is near ambient pressure. This sample pressure is displayed in the test menu. A solid state flow sensor measures the sample flow. Likewise, it is displayed as a TEST function. The M100A displays pressure in inches of mercury-absolute (in-Hg-A) and flow in cc/min.

### 4.2.3 Computer Hardware and Software

The M100A Analyzer is operated by an 8088 type micro-computer. The computer's multitasking operating system allows it to do instrument control, monitor test points, provide analog output and provide a user interface via the display, keyboard and the RS-232 port. These operations appear to be happening simultaneously but are actually done sequentially based on a priority queuing system maintained by the operating system. The jobs are queued for execution only when needed, therefore the system is very efficient with computer resources.

The M100A is a true computer based instrument. The microprocessor does most of the instrument control functions such as temperature control, valve switching. Data collection and processing are done entirely by the CPU with the final concentration values being sent to a D/A converter to produce the instrument analog output.

The computer memory is divided into 3 sections: EPROM memory contains the multi-tasking operating system code plus the instructions that run the instrument. The RAM memory is used to hold temporary variables and current concentration data. The EEPROM memory contains the instrument set-up variables such as range and instrument ID number. The EEPROM data is non-volatile so the instrument can lose power and the current set-up information is preserved.

### 4.2.4 V/F Board

Computer communication is done via 2 major hardware assemblies. These are the V/F board and the front panel display/keyboard.

The V/F board is multifunctional, consisting of A/D input channels, digital I/O channels, and analog output channels. Communication with the computer is via a STD bus interface. The computer receives all of the instrument data and provides all control functions through the V/F board.

### 4.2.5 Front Panel

The front panel of the M100A is shown in Figure 2-4. The front panel consists of a 2 line display and keyboard, 3 status LED's and power switch. Communication with the display, keyboard, and status LED's is done via the computer's on-board parallel port. The M100A was designed as a computer controlled instrument, therefore all major operations can be controlled from the front panel display and keyboard.

The display consists of 2 lines of 40 characters each (see Figure 4-2). The top line is divided into 3 fields, and displays information. The first field is the mode field.

**Table 4-1: System Modes Display**

Mode	Meaning
SAMPLE xx(1)	Sampling normally
SAMPLE xx(1)	Flashing indicates adaptive filter is on
ZERO CAL x(2)	Doing a zero check or adjust
SPAN CAL x(2)	Doing a span check or adjust
MP CAL	Doing a multi-point calibration
SETUP xxx(3)	Configuring analyzer (sampling continues)
DIAG xxx(4)	Diagnostic test mode
	(1)xx= A (auto) (2)x= M (manual), A (auto), R (remote) (3)xxx= software revision (e.g.H.3) (4)xxx= I/O (Signal I/O), AOUT (analog output), D/A (DAC cal.), OPTIC (Optic test), Elec (Electrical test), RS232 (RS-232 test), LAMP (Lamp cal.), TCHN (Test channel).

The mode field indicates the current mode of the Analyzer. Usually, it shows "SAMPLE", indicating that the instrument is in sample mode.

The center field displays TEST values. The TEST functions allow you to quickly access many important internal operating parameters of the M100A. This provides a quick check on the internal health of the instrument. The right hand field shows current concentration value of SO<sub>2</sub>.

#### 4.2.5.1 Front Panel Display

The second line of the display contains eight fields. Each field defines the key immediately below it. By redefining the keys dynamically it is possible to simplify the instrument electronics and user interface.

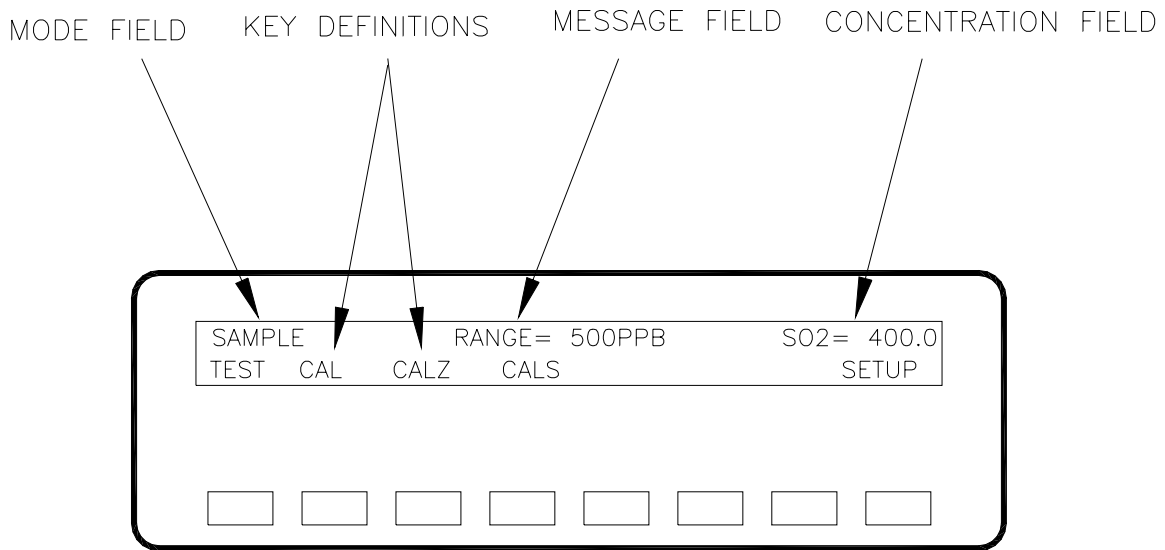

ILLUSTRATION OF NORMAL DISPLAY IN SAMPLE MODE

**Figure 4-2: Front Panel Display**

#### 4.2.5.2 Status LED's

At the right of the display there are 3 status LED's. They can be in three states, OFF, ON, and Blinking. The meanings of the LED's are given in Table 4-2.

**Table 4-2: Front Panel Status LED's**

LED	State	Meaning
Green	Off	NOT monitoring, DAS Disabled or inactive
	On	Monitoring normally, taking DAS data
	Blinking	Monitoring, DAS in HOLDOFF mode (1)
Yellow	Off	Auto cal. disabled
	On	Autocal. Enabled
	Blinking	Calibrating
Red	Off	Warnings exist
	Blinking	No warnings exist
(1) This occurs during Calibration, DAS holdoff, Power-up Holdoff, and when in Diagnostic mode.		

#### 4.2.5.3 Power Switch

The power switch has two functions. The rocker switch controls overall power to the instrument; in addition it includes a circuit breaker. If attempts to power up the M100A result in a circuit breaker trip, the switch automatically returns to the off position, and the instrument will not power up. If this occurs, consult troubleshooting section or factory.

#### 4.2.6 Power Supply Module

The Power supply module (PSM) supplies AC and DC power to the rest of the instrument. It consists of a 4 output linear DC power supply and a 15 volt switching supply. In addition, it contains the switching circuitry to drive the DC operated valves and several switched AC loads to operate the reaction cell and IZS heaters.

#### 4.2.7 Pneumatic System

In the basic analyzer, the sample enters through a 5-micron TFE filter element. The sample then enters the KICKER and the reaction cell. The internal (external optional) pump is supplied as standard equipment with the M100A.

When the zero/span valve option is included, the sample passes through the TFE zero valve and then enters the sample filter. (See Section 6) By having the sample gas, zero air and span gas all pass through the sample filter, the effects of the filter are common to all gases.

Sample flow is controlled by a critical flow orifice. The orifice is a precision-drilled sapphire jewel protected by a 20-micron sintered filter. The orifice never needs adjustment. The critical flow orifice maintains precise volumetric flow control as long as the pump inlet pressure is maintained at or near 14"(350mm) Hg absolute.

**Note on sample flow reading:**

At altitude, the front panel "sample flow" reading will be lower than at sea level. Actually, the volumetric flow is the same at all altitudes. However, the internal mass flowmeter measures weight flow. Therefore, as the altitude increases, the indicated flow decreases because of the reduced incoming air density. Flow variations have a negligible effect on the analyzer reading.

## 5 SOFTWARE FEATURES

This section covers the software features of M100A which is designed as a computer controlled instrument. All major operations are controlled from the front panel display and keyboard through friendly menu. **Sample mode** is explained for the basic operation of the analyzer including calibration steps. Advanced software features are covered for experienced users under the **Setup mode** offering advanced instrument control capabilities for optimum operation of the instrument. For installation and initial operation, please see "Section 2 Getting Started".

### 5.1 Index To Front Panel Menus

The next several pages contain two different styles of indexes that will allow you to navigate the M100A software menus. The first two pages show a "tree" menu structure to let you see at a glance where each software feature is located in the menu. The second menu contains a brief description of each key mnemonic and a reference to the section of the manual that describes its purpose and function in detail.

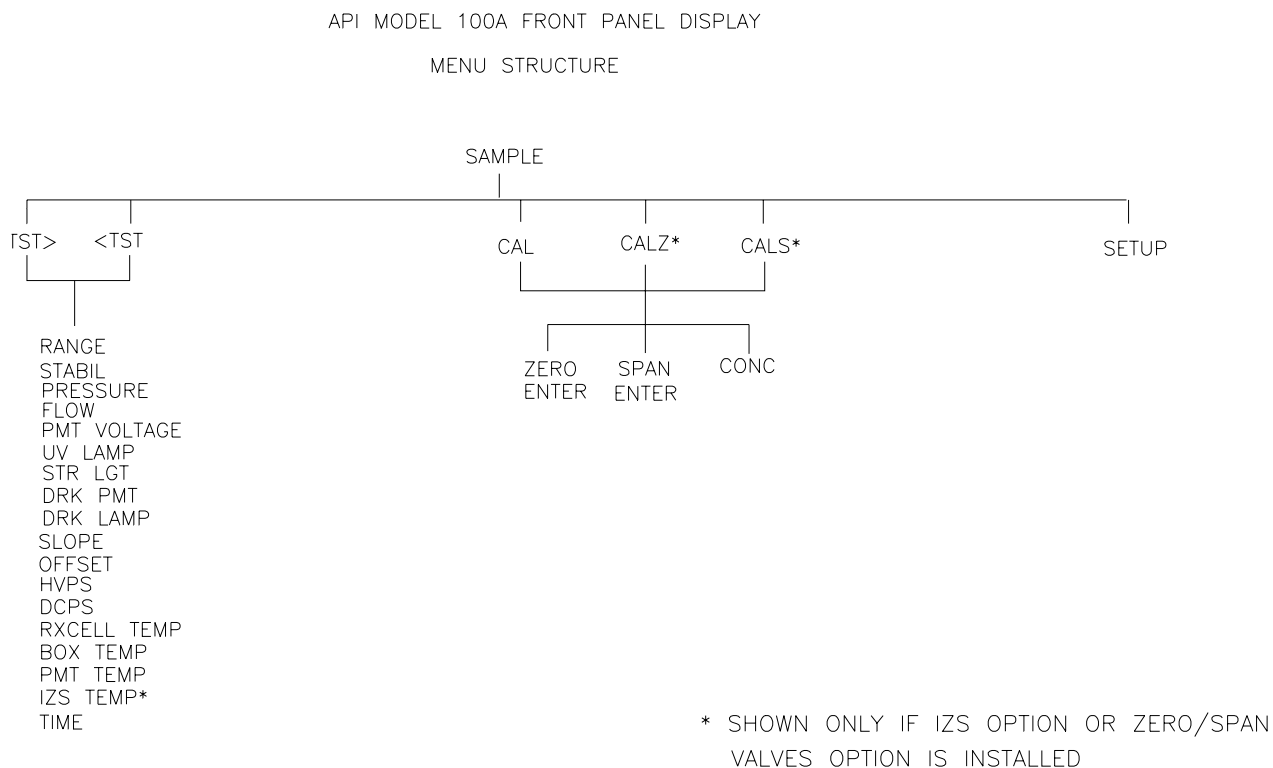

**Figure 5-1: Sample Menu**

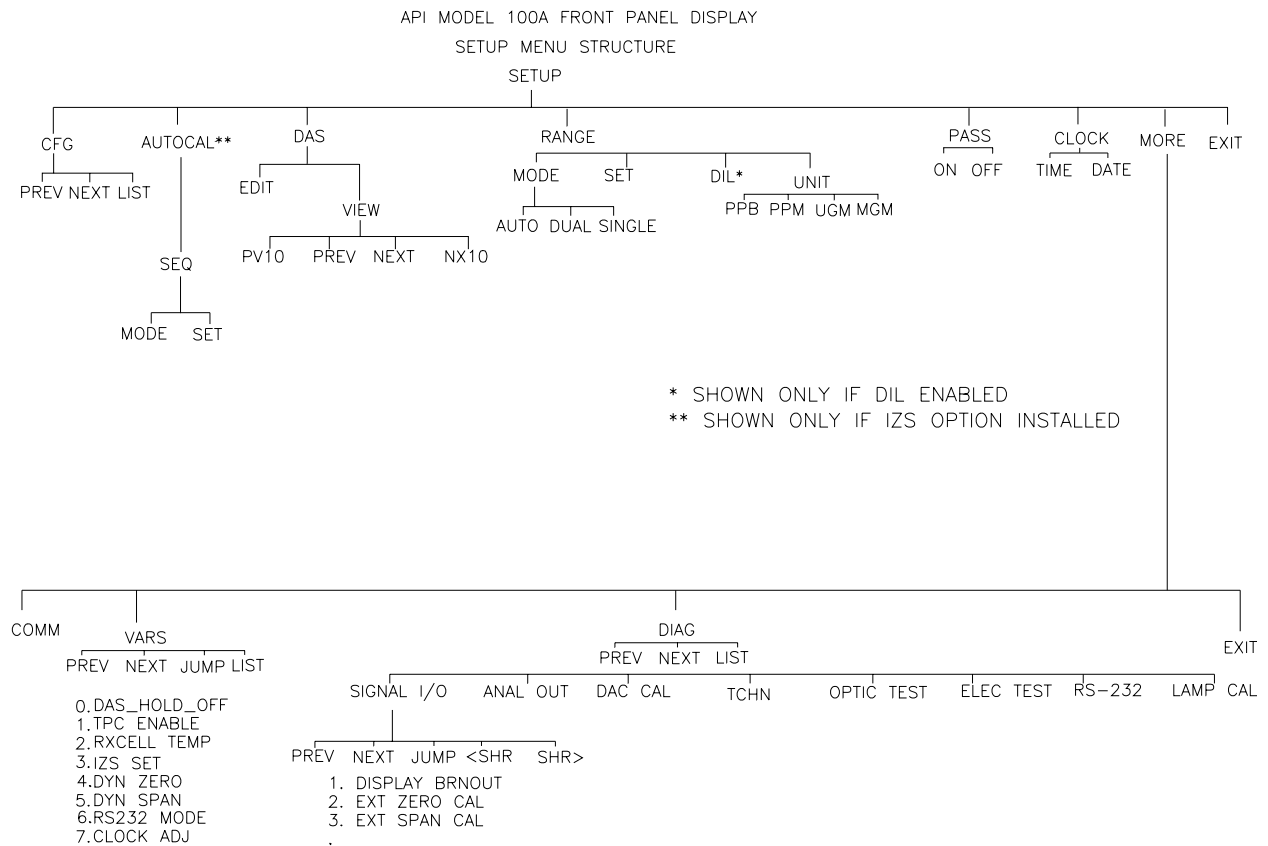

**Figure 5-2: Setup Menu Tree**

### 5.1.1 Sample Menu

**Table 5-1: M100A Sample Menu Structure**

Menu Level				Description	Reference Section
Level 1	Level 2	Level 3	Level 4		
TEST TST>				Test functions	5.2.1, Table 9-1
CAL				Zero/Span calibration w/ gas through sample port	5.2.2.1,7.1
CALZ				Zero calibration w/ zero gas from zero valve option or IZS option	5.2.2.2,7.2, 7.3
CALS				Span calibration w/ span gas from span valve option or IZS option tube	5.2.2.3, 7.2, 7.3
	ZERO			Press ZERO then ENTR will zero analyzer	5.2.2.2
	SPAN			Press SPAN then ENTR will span analyzer	5.2.2.3
	CONC			Expected SO <sub>2</sub> span concentration	
SETUP				The SETUP Menu - See next table below	Table 5-2

## 5.1.2 Set-Up Menu

Table 5-2: M100A Setup Menu Structure

Setup Menu #1					
Level 1	Level 2	Level 3	Level 4	Description	Reference Section
CFG				CFG is primarily used for showing special configuration options and factory special software	5.3.1
	PREV, NEXT, LIST			PREV, NEXT can be used to scroll through the configuration list  LIST automatically scrolls the list	5.3.1
AUTOCAL				Automatic zero/span check or calibration	5.3.2, 6.2
	SEQ <sub>x</sub>			Select SEQUENCE 1 thru 3	5.3.2, 6.2
		MODE		Disable or enable zero and/or span mode	5.3.2, 6.2
		SET		SETUP automatic zero/span calibration sequence	5.3.2, 6.2
DAS				Data Acquisition System (DAS)	5.3.3
	EDIT			SETUP Data Acquisition System (DAS)	5.3.3
	VIEW	PREV		Examine the DAS data buffer - display previous average	5.3.3
		PV10		Move UP previous 10 averages in the DAS data buffer	5.3.3
		NEXT		Examine the DAS data buffer - display next average	5.3.3
		NX10		Display next 10 averages in the DAS data buffer	5.3.3

**Table 5-3: M100A Menu Structure - Setup Menu #2**

Setup Menu #2					
Level 1	Level 2	Level 3	Level 4	Description	Reference Section
RNGE				Range control menu	5.3.4
	MODE			Range mode select - Single, Autorange, Dual	5.3.4
		AUTO		Automatically select output range	5.3.4
		DUAL		Independent output ranges for REC and DAS	5.3.4
		SINGLE		Single range for both REC and DAS outputs	5.3.4
	SET			Sets range if mode is Single range	5.3.4.1
		LO		Sets low range value if Autorange enabled	5.3.4.2
		HI		Sets high range value if Autorange enabled	5.3.4.2
	UNITS			Unit selection menu	5.3.4.5
		PPB, PPM, UGM, MGM		Select units that instrument uses	5.3.4.5
PASS				Password enable/disable menu	5.3.5
	ON-OFF			Enable/disable password checking	5.3.5
CLOCK	TIME			Adjusts time on the internal time of day clock	5.3.6
	DATE			Adjusts date on the internal time of day clock	5.3.6
MORE				Continue menu one MORE level down	Table 5-3

**Table 5-4: M100A Menu Structure - Setup Menu #3**

Setup Menu #3					
Level 1	Level 2	Level 3	Level 4	Description	Reference Section
MORE				Next level of the SETUP menu	
	COMM			RS-232 communications control menu	
		BAUD	300-1200-2400-4800-9600-19.2k	Set the BAUD rate to 300-1200-2400-4800-9600-19.2K	5.3.8, 6.8
		ID		Sets the instrument ID-(included on all RS-232 messages)	5.3.8, 6.8
	VARS			Internal variables	5.3.9, 9.1.4
		PREV, NEXT, JUMP, EDIT		PREV, NEXT scroll up and down through the VARS menu. Jump will go to variable number selected, EDIT will allow editing of the selected variable.	5.3.9, 9.1.4
	DIAG			Diagnostic menu	5.3.7, 9.1.3
		PREV, NEXT.		PREV, NEXT scroll up and down through the DIAG menu.(SIGNAL I/O, ANALOG OUTPUT, D/A CALIBRATION, OPTIC TEST, ELECTRICAL TEST, LAMP CALIBRATION, TEST CHAN OUTPUT, RS-232 OUTPUT)	5.3.7, 9.1.3

## 5.2 Sample Mode

### 5.2.1 Test Functions

**NOTE**

**In any of the following TEST functions, if XXXX is displayed, that indicates an off scale and therefore meaningless reading.**

To use the TEST functions to diagnose instrument faults, refer to Troubleshooting Section 9.1.

#### **Range**

This is the range of the instrument. In standard configuration there is one range for both REC and DAS outputs.

Dual range allows a different range for each output. When enabled, the RANGE test measurement is replaced with two different test measurements, RANGE1 (REC) and RANGE2 (DAS).

Auto range option allows a low range and high range. The M100A will automatically switch to the other range dynamically as concentration values require. The TEST values will show the range the instrument is currently operating in, and will dynamically display the alternate range as the range changes occur.

#### **Stability**

The instrument stability is used to indicate the stability of measurement of analyzer. It is computed as the standard deviation of 25 samples of a moving window with interval of 10 seconds between each sample. Typical value is 0.1 to 2 ppb when sampling constant concentration of gas.

#### **Pressure**

Sample pressure is measured using solid state pressure sensor at the downstream of the reaction cell. This reading will vary according to the altitude and local weather condition. This reading is used by the CPU to compensate the SO<sub>2</sub> concentration due to its pressure of the sample gas.

#### **Sample Flow**

A solid state mass flowmeter measures the sample flow which is the weight flow and the reading will be lower at altitude. (See Section 4.2.7) Its nominal value is 650 ± 65 cc/min.

### **PMT Voltage**

The PMT VOLTAGE measures the PMT signal at the output of the preamp board. The waveform of the PMT voltage can be complex, and vary up to 5000 mV when a high concentration of SO<sub>2</sub> is being measured. If the PMT reading is consistently 5000 mV, that indicates an off-scale reading. Typical readings bounce around, which is normal.

### **UV Lamp**

UV Lamp reading is the measurement voltage from the reference detector preamp board. Reference detector is solar blind and facing directly into the UV lamp. Typical value is between 2000 mV and 4000 mV. The minimum acceptable level is 1000 mV.

### **Stray Light**

Stray Light is the background light of the reaction cell expressed in ppb while sampling zero gas. It is only the indication of condition of the optical system such as lenses, UV filter, light leak, etc.

### **Dark PMT**

This dark current of the PMT is measured periodically to compensate any PMT dark current drift. Typical value is near  $-50 + 200$  mV.

### **Dark Lamp**

This is the dark current of the UV reference detector which is used to compensate any dark current drift. This measurement is synchronized to the Dark PMT measurement period. Typical value is near  $-50 + 200$  mV.

### **Slope**

The coefficient of straight line equation ( $y=mx + b$ ) determines the calibration of the M100A. The slope parameter (m) can be thought of as a gain term which determines the steepness of the calibration curve.

### **Offset**

The offset parameter (b) compensates for differences in the background signal of the optical system.

### **High Voltage Power Supply(HVPS)**

The HVPS reading is a measure of the scaled-up HVPS programming voltage. The voltage used to set the HVPS output is generated on the preamp board. Its value is between 0 and 1 volt, corresponding to a voltage of 0 to 1000 volts out of the HVPS. The HVPS front panel TEST measurement should be greater than 500 volts and will typically be around 550-900V.

### **DC Power Supply (DCPS)**

The DCPS voltage is a composite of the 5 and  $\pm 15$ VDC voltages in the Power Supply Module. This is meant to be a quick indicator to show if the PSM is working correctly. The nominal value is  $2500\text{mV} \pm 200\text{mV}$ .

### **Reaction Cell Temperature**

This is a measurement of the temperature of the reaction cell. It is controlled by the computer to  $50 \pm 1^\circ\text{C}$ . Temperatures outside this range will cause the M100A output to drift.

### **Box Temperature**

This TEST function measures the temperature inside the chassis of the M100A. The temperature sensor is located on the Status/Temp Board. Typically it runs 2 to  $10^\circ\text{C}$  higher than the ambient temperature. The M100A has been engineered to maintain stable output over 5 to  $40^\circ\text{C}$  ambient temperature range.

### **PMT Temperature**

The temperature of the PMT is closely controlled by a dedicated proportional temperature controller. The nominal set-point is  $7 \pm 1^\circ\text{C}$ . Readings outside this range will cause instrument drift due to gain changes in the PMT detector.

### **IZS Temperature**

The IZS option has an oven for SO<sub>2</sub> permeation tubes. The oven temperature is nominally 50C. The actual temperature is stable to  $\pm 0.1^\circ\text{C}$  although it is normal to see the temperature on the front panel move  $\pm 0.3^\circ\text{C}$  due to the proximity of the temperature sensor to the heater. It can be adjusted from the front panel by pressing SETUP-MORE-VARS and selecting the IZS\_SET item and entering the desired temperature. Using this adjustment, the permeation rate of the SO<sub>2</sub> permeation tube can be adjusted to a desired value. See Section 9.3.4 for information on adjusting the IZS temperature.

### **Time**

This is an output of the M100A's internal time of day clock.

## 5.2.2 CAL, CALS, CALZ, Calibration Functions

The calibration and zero/span checking of the M100A analyzer is treated in detail in Section 7. Table 7-1 summarizes types of calibration. The basic function of each of these keys is described here.

### 5.2.2.1 CAL, CALS, CALZ

The above keys control the calibration functions of the analyzer. In the CAL mode the analyzer can be calibrated with zero/span gas coming in through the sample input port on the rear panel. If the analyzer is equipped with the IZS option, or Zero/Span valves, there will be CALZ and CALS buttons also. These buttons operate the Zero/Span valves or IZS system. The setup of these options is covered in Section 6.3, and operation is explained in Section 7.

### 5.2.2.2 Zero

Pressing the ZERO key along with ENTR will cause the instrument to adjust the OFFSET value of the internal formula so that the instrument reads zero. The M100A allows zero adjustment over a limited range of signal levels mostly due to the background signal, therefore the signal does not have to be exactly zero for the instrument to do a zero cal. The instrument will not, however, allow a zero cal on any signal level, therefore it is not possible to zero the instrument with span gas in the reaction cell. If the ZERO key does not come on as expected, check Section 9.2.9.

### 5.2.2.3 Span

Pressing the SPAN key along with ENTR will cause the instrument to adjust the SLOPE value of the internal formula so the instrument displays the span value. The expected SO<sub>2</sub> span concentration must be entered before doing a SPAN calibration. See Table 7-3.

Like the Zero calibration, the Span cal cannot be done with any concentration of span gas. If the signal level is outside certain limits, the SPAN key will not be illuminated. If you encounter this condition see Section 9.2.8. It is also possible at low levels of span concentration that both the ZERO and SPAN keys might be on, thus allowing you to either zero or span the instrument. In this case, care must be taken to perform the correct operation or the analyzer can become mis-calibrated.

### 5.2.2.4 SO<sub>2</sub> Cal Concentration

Before the M100A can be spanned, it is necessary to enter the expected span concentrations for SO<sub>2</sub>. This is done by using CAL-CONC. Concentration values from 50 to 19000 ppb are accepted. If a value of XXXX is displayed, that indicates an offscale, or invalid reading. The XXXX value will often be displayed at power-up when there is no data yet available to be displayed. Certain instrument fault conditions will cause X's to be displayed, this is the same as the needle being offscale on an analog meter. See the Troubleshooting Section 9.2.8 if this occurs.

### 5.2.2.5 Formula Values

The slope and offset terms should be checked after each calibration. The values for these terms contain valuable information about the internal health of the analyzer. The range of acceptable values and their meanings is given in Section 7.10.

To compute the SO<sub>2</sub> concentration, the formula for a straight line is used.

$$y = mx - b$$

Where:

y = the SO<sub>2</sub> concentration

m = the slope

x = the conditioned PMT tube output

b = the offset

In comparison with analog analyzers the slope term is equivalent to the "span pot" and the b term is equivalent to the "zero pot". Again, like an analog analyzer there is only a limited range of adjustment allowed for either term, and there are consequences of having the values near the high or low limits of their respective ranges.

The x term is the conditioned PMT signal. PMT signal is adjusted for the lamp ratio background, range, temperature, and pressure.

The offset (b) term is the total background light with the zero term subtracted out. The zero term measures detector dark current and amplifier noise. The b term is composed mostly of the optical system background.

After every zero or span calibration check the QUALITY of the calibration. The calibration of the M100A involves balancing several sections of electronics and software to achieve an optimum balance of accuracy, noise, linearity and dynamic range. See Section 7.10 for the calibration quality check procedure.

## 5.3 Set-Up Mode

### 5.3.1 Configuration Information (CFG)

This menu item will tell if the installed software has factory special features or other non-standard features. If you call Teledyne API service you may be asked for information from this menu.

### 5.3.2 Automatic Calibration (AutoCal)

The AutoCal feature allows the M100A to automatically operate the Zero/Span Valve or IZS option on a timed basis to check or adjust its calibration. This menu item is shown only if the IZS or Zero/Span Valve option is installed. Detailed information on setting up AutoCal is found in the Section 6.4.

### 5.3.3 Data Acquisition System (DAS)

The Model 100A contains a flexible and powerful built in data acquisition system(DAS) that enables the analyzer to store concentration data as well as many diagnostic parameters in its battery backed memory. This information can be viewed from the front panel or printed out through the RS-232 port. The diagnostic data can be used for performing “Predictive Diagnostics” and trending to determine when maintenance and servicing will be required.

The logged parameters are stored in what are called “Data Channels.” Each Data Channel can store multiple data parameters. The Data Channels can be programmed and customized from the front panel. A set of default Data Channels has been included in the Model 100A software. These are described Section 5.3.3.1. For more information on programming custom Data Channels, a supplementary document containing this information can be requested from Teledyne API.

#### 5.3.3.1 Data Channels

The function of the Data Channels is to store, report, and view data from the analyzer. The data may consist of SO<sub>2</sub> concentration, or may be diagnostic data, such as the sample flow or PMT output.

The M100A comes pre-programmed with a set of useful Data Channels for logging SO<sub>2</sub> concentration and predictive diagnostic data. The default Data Channels can be used as they are, or they can be changed by the user to fit a specific application. They can also be deleted to make room for custom user-programmed Data Channels.

The data in the default Data Channels can be viewed through the **SETUP-DAS-VIEW** menu. Use the **PREV** and **NEXT** buttons to scroll through the Data Channels and press **VIEW** to view the data. The last record in the Data Channel is shown. Pressing **PREV** and **NEXT** will scroll through the records one at a time. Pressing **NX10** and **PV10** will move forward or backward 10 records. For Data Channels that log more than one parameter, such as PNUMTC, buttons labeled

<PRM and PRM> will appear. These buttons are used to scroll through the parameters located in each record.

The function of each of the default Data Channels is described below:

- CONC:** Samples SO<sub>2</sub> concentration at one minute intervals and stores an average every hour with a time and date stamp. Readings during calibration and calibration hold off are not included in the data. The last 800 hourly averages are stored.
- PNUMTC:** Collects sample flow and sample pressure data at five minute intervals and stores an average once a day with a time and date stamp. This data is useful for monitoring the condition of the pump and critical flow orifice (sample flow) and the sample filter (clogging indicated by a drop in sample pressure) over time to predict when maintenance will be required. The last 360 daily averages (about 1 year) are stored.
- CALDAT:** Logs new slope and offset every time a zero or span calibration is performed. This Data Channel also records the instrument reading just prior to performing a calibration. *Note:* this Data Channel collects data based on an event (a calibration) rather than a timer. This Data Channel will store data from the last 200 calibrations. This does not represent any specific length of time since it is dependent on how often calibrations are performed. As with all Data Channels, a time and date stamp is recorded for every data point logged.

### **5.3.4 Range Menu**

The instrument operates on any full scale range from 50 to 20,000 ppb. The range is the concentration value that equals the maximum voltage output on the rear panel of the instrument.

If the range you select is between 50 and 2000 ppb the front panel will read the concentration anywhere from 0 to 2000 ppb regardless of the range selected. If the range selected is from 2001 to 20,000 ppb the front panel will read from 0 to 20,000 ppb. The apparently wider range of front panel readouts is because the M100A has 2 internal hardware gain settings, namely 0-2000ppb (gain of 10) and 0-20,000ppb (gain of 1). If the physical gain changes, then the test measurement readings such as PMT, DARK PMT, and OFFSET will be adjusted accordingly. The analog output is scaled for the range selected, however the front panel reading can display correct concentrations over the entire physical range. If the instrument will be used on more than one range such as AUTO RANGE or DUAL RANGE, it should be calibrated separately on each applicable range (see Section 7.9 for calibration procedure).

**NOTE**

**Only one of the following range choices can be active at any one time.**

There are 3 range choices:

1. Single Range
18. Auto Range
2. Dual Ranges

#### **5.3.4.1 Single Range**

This range option selects a single range for both output channels (REC, DAS) of the M100A. To select Single Range press SETUP-RNGE-MODE-SING, then press ENTR. To set the value for the range press SETUP-RNGE-SET, and enter the full scale range desired from 50 ppb to 20,000 ppb, then press ENTR.

#### **5.3.4.2 Auto Range**

Auto Range allows output range to automatically range between a low value (RANGE1) and a higher value (RANGE2). When the instrument output increases to 98% of the low range value, it will Auto Range into Hi range. In Hi range, when the output decreases to 75% of low range, it will change to the lower range. This is only one low range and one high range for all outputs. The Hi range mode is signaled by a bit on the STATUS option, see Table 6-3. If you select a Hi range that is less than Low range, the M100A will remain locked in Low range and behave as a Single Range instrument.

To set up Auto Range press SETUP-RNGE-MODE-AUTO, then press ENTR. To set the values press SETUP-RNGE-SET. The M100A will prompt you for Low Range, then Hi Range which is the lower and upper ranges of Auto Range. Key in the values desired, then press ENTR.

Once desired range is selected, then M100A should be calibrated for each range entered. (Refer to Section 7.9 for Calibration Procedure.)

### 5.3.4.3 Dual Ranges

Dual Ranges allows you to select different ranges for REC and DAS analog output channels. To set up Dual Ranges press SETUP-RNGE-MODE-DUAL, then press ENTR. To set the values press SETUP-RNGE-SET. The M100A will prompt you for the range of RANGE1 (REC) and RANGE2 (DAS) outputs (refer to Figure 2-2 for corresponding analog output terminals). Key in the desired range for each output channel, then press ENTR after each value.

If Dual Range is selected and their desired ranges are entered accordingly, the M100A should be calibrated for each of the range selected. See Section 7.9 for Calibration Procedure.

If user has selected either Auto Range or Dual Range, then pressing CAL button will cause to display #1 and #2. #1 means RANGE1 calibration and #2 means RANGE2 calibration. Select desired range number and press ENTR to continue calibration procedure of selected range. Under each range calibration procedure, the M100A will display separate test measurement functions accordingly to show the Slope, Offset, Range, etc for corresponding range. However once exit this calibration menu and return to the main menu (see Figure 2-4), then the test measurement parameters for RANGE1 are used throughout the M100A.

**When initiating calibration remotely via the contact closures, the RS-232, or automatically via the timer, the M100A will calibrate RANGE #1.**

### 5.3.4.4 Dilution Ratio

The dilution feature allows the M100A to be used with a stack dilution probe. With the Dilution feature you can select the range and display the concentration at the value and units of the un-diluted gas in the stack. The dilution probe dilutes the gas by a fixed ratio so the analyzer is actually measuring a much lower concentration than is actually present in the stack.

The software scales the diluted sample gas concentration readings so that the outputs show the actual stack concentrations. Also, when calibrating the instrument or setting the ranges the values selected are scaled to reflect the actual stack concentrations. The scaled readings are sent to the display, analog outputs, and RS-232 port.

To use the Dilution feature:

## 19. SELECT UNITS

For stack measurement, select PPM units. To set units, press SETUP-RANGE-UNIT-PPM. Press ENTR after the unit selection is made, then EXIT to return to upper level menus.

## 2. SET DILUTION RATIO

The dilution ratio of the probe is entered by SETUP-RANGE-DIL (if DIL menu is not shown call factory). Accepted values are 1 to 1000. Press ENTR, and EXIT to return to upper level menus. A value of 1 disables the dilution feature.

### 3. SELECT RANGE

The range selection is the same with dilution as with normal monitoring. See Section 5.3.4 for information on range selection. You should note however, the value entered should be the actual concentration of the calibration gas entering the dilution probe. The units of this number is ppm.

## 20. CALIBRATION

When the above selections have been made, the instrument now must be calibrated through the dilution probe. NOTE: units are now in PPM. See Section 7 for calibration methods.

### 5.3.4.5 Concentration Units

The M100A can display concentrations in ppb, ppm, ug/m<sup>3</sup>, mg/m<sup>3</sup>. Coefficients for mg/m<sup>3</sup> and ug/m<sup>3</sup> were based on 0°C (25°C for U.S.EPA), 760 mmHg. Different pressure and temperature can be used by adjusting values entered for calibration gas to read the correct concentration at the conditions being used. This adjustment is not needed if units are within the same type.

To change the current units press SETUP-RNGE-UNIT from the SAMPLE mode and select the desired units.

Example: If the current units are in ppb and the span value is 400 ppb, and the units are changed to ug/m<sup>3</sup> the span value is NOT re-calculated to the equivalent value in ug/m<sup>3</sup>. Therefore the span value now becomes 400 ug/m<sup>3</sup> instead of 400 ppb. Use following equation to convert the unit with proper temperature and pressure adjustments.

$$SO_2 \text{ in ppm} \times 2.86 \times \frac{T}{273^\circ K} \times \frac{760 \text{ mmHg}}{P} = SO_2 \text{ in } \frac{mg}{m^3}$$

#### NOTE

**You should now reset the expected span concentration value which should be adjusted with proper pressure and temperature(25°C for U.S.EPA) in the new units and re-calibrate the instrument using one of the methods in Section 7.**

**Changing units affects all of the RS-232 values, all of the display values, and all of the calibration values and therefore you must recalibrate the analyzer.**

### 5.3.5 Password Enable

There are two levels of password protection. The most restrictive level requires a password to do instrument calibration. The second level requires a password to do SETUP functions.

If both password levels are turned off, no passwords are required, except in the VARS menu where a password is always required. To enable password press SETUP-PASS-ON. A list of passwords is in Table 5-5.

**Table 5-5: Calibrate, Setup Passwords**

Password Usage		Password
Calibration Password	Use to get into CAL menus	512
Setup Password	Use to get into SETUP menus	818

### 5.3.6 Time of Day Clock

The instrument has an internal time of day clock. The time of day can be set by pressing SETUP-CLOCK-TIME and entering the time in 24hr format. In a similar manner the date can be entered by pressing SETUP-CLOCK-DATE and entering the date in a dd-mmm-yy format. If you are having trouble with the clock running slow or fast, the speed of the clock can be adjusted by selecting the CLOCK\_ADJ variable in the SETUP-MORE-VARS menu(See Section 9.1.4).

### 5.3.7 Diagnostic Mode

The M100A Diagnostic Mode allows additional tests and calibrations of the instrument. These features are separate from the TEST functions because each DIAG function has the ability to alter or disable the output of the instrument. While in DIAG mode no data is placed in the DAS averages. Details on the use of Diagnostic mode are in Section 9.1.3.

### 5.3.8 Communications Menu

The COMM menu allows the RS-232 BAUD rate to be set. To set the BAUD rate press SETUP-MORE-COMM-BAUD, select the appropriate BAUD rate, then press ENTR.

The instrument ID number can also be set. This ID number is attached to every RS-232 message sent by the M100A. To set the ID press SETUP-MORE-COMM-ID and enter a 4 digit number from 0000-9999, then press ENTR.

### 5.3.9 Variables Menu (VARS)

This menu enables you to change the settings on certain internal variables. The VARS Table 9-5 is located in the Troubleshooting Section 9.1.4.

**NOTE**

**Before changing the settings on any variables, please make sure you understand the consequences of the change. The variables should only be changed by skilled maintenance people since they can potentially interfere with the performance of the analyzer.**

## 6 OPTIONAL HARDWARE AND SOFTWARE

Optional equipment offered with the M100A includes:

Rack mount with slides (P/N 00280).

Rack mount without slides, ears only (P/N 01470).

Fluorocarbon zero/span valves (P/N 01491).

Internal zero/span - IZS (P/N 01441).

4-20mA, isolated outputs(P/N 01471).

External pump

DB-50 Connector for data inputs

### 6.1 Rack Mount Options

Rack Mount including slides and ears, permits the Analyzer to be mounted in a standard 19" wide by 24" deep RETMA rack. Can also be ordered without slides for applications requiring the instrument to be rigidly mounted in a RETMA rack.

### 6.2 Zero/Span Valves

The Zero/Span Valve option consists of two fluorocarbon solenoid valves. See Figure 2-5 for valve location. Connections are provided on the rear panel for span gas and zero gas inputs to the valves(See Figure 2-2). These valves can be actuated by several methods shown in Table 6-1.

**Table 6-1: Zero/Span Valve Operation**

Mode	Description	Reference Section
1.	Front panel operation via CALS and CALZ buttons.	Calibration Section 7 - Manual Zero/Span Check.
2.	Automatic operation using AUTOCAL	Setup and use of AUTOCAL is described in and Section 7.4.
3.	Remote operation using the RS-232 interface	Setup described in Table 6-2 Operation of AUTOCAL described in Section 6.8.5 and Section 7 - Calibration.
4.	Remote operation using external contact closures	Section 7.7 - Automatic operation using external contact closures. Truth Table 7-8 and Section 9.3.4.3.

Zero/Span valves have 3 operational states:

1. Sample mode. Here both valves are un-energized and sample gas passes through the sample/cal valve and into the analyzer for analysis.
2. Zero mode. The sample/cal valve is energized to the cal mode. The zero/span valve is un-energized in the zero mode, thus allowing zero gas to be admitted through the rear panel bulkhead fitting into the analyzer.
3. Span mode. The sample/cal valve is energized and in the cal mode. The zero/span valve is energized in the span mode. With both valves on, span gas is admitted through a rear panel bulkhead fitting into the analyzer.

Zero air and span gas inlets should supply their respective gases in excess of the 700 cc/min demand of the analyzer. Supply and vent lines should be of sufficient length and diameter to prevent back diffusion and pressure effects. See Figure 2-3 for fitting location and tubing recommendations.

Adequate zero air can be supplied by connecting a charcoal scrubber and 5 micron particulate filter (Teledyne API P/N 000369) to the zero air inlet tubing. The zero air scrubber used in conjunction with the Zero/Span Valve option provides an inexpensive source of zero air.

## 6.3 Internal Zero/Span (IZS)

The IZS option includes the Zero/Span Valves described above, a temperature-controlled permeation tube oven, and rear panel mounted zero air scrubber. The IZS system is activated by the same methods as described in Table 6-1 for the zero/span valves. The setup of the IZS is the same as that of the valves and is described in Table 6-2.

The IZS system operation is similar to the zero/span valve operation, except that the source of the zero air and span gas are supplied at the analyzer via a scrubber and permeation tube respectively. See Section 7.1 - calibration for operational details. A continuous purge flow of approximately 50cc/min is drawn across the permeation tube to prevent span gas accumulation when the permeation tube is not in use.

## 6.4 Autocal - Setup of IZS and Zero/Span Valves

The Zero/Span valves or the IZS system can be set up to operate automatically on a timed basis. The Teledyne API model 100A with IZS option offers capability to check any combination of zero and span points automatically on a timed basis, through remote RS-232 operation (see Section 6.8.5), or external contact closure (see Section 7.7).

There are three auto-calibration sequences called SEQ1, SEQ2, and SEQ3. Under each SEQ, there are five parameters that affect zero/span checking: the mode enable/selection, the starting date and time of the calibration, the number of delay days and time, duration of calibration, and calibration adjust enable/disable.

### 1) Calibration Sequence Mode

Each sequence can generate any one of 3 different combinations of ZERO, or HI span point. Press SETUP-ACAL, and scroll up or down to select of the SEQx. Press MODE and scroll up or down by pressing PREV or NEXT. Select one of the combination shown below and press ENTR .

- Combinations:
- 1) DISABLED; will disable corresponding SEQx setup.
  - 2) ZERO
  - 3) ZERO-HI
  - 4) HI

### 2) Setup Calibration Timer:

Press SETUP-ACAL-SET to setup or edit the automatic calibration timer.

Following table summarizes the setup procedures;

**Table 6-2: Setup Automatic Zero/Span Calibration**

	Default	Description
Timer Enable	ON	Enable or disable automatic calibration timer.
Starting Date	01-JAN-95	MM:DD:YY
Starting Time	00:00	HH:MM, 0 - 23 hours and 0 - 59 minutes
Delta Days	1	Delay days between each calibration (0 - 365 days)
Delta Time	00:00	HH:MM, 0 - 23 hours and 0 - 59 minutes
Duration	15.0 minutes	1 - 60.0 minutes
Calibrate	OFF	on/off. If ON is selected, it will adjust the calibration.

The Timer Enable can be set to “OFF” to disable the automatic calibration timer while the remote RS-232 calibration of specific sequence can be initiated.

**NOTE**

**Avoid setting two or more sequences at the same time of the day. Any new sequence which is initiated whether from a timer, the RS-232, or the contact closure inputs will override any sequence which is in progress.**

**The programmed start time must be a minimum of 5 minutes later than the real time clock.**

Examples of possible sequences are as following under any one of three available SEQx.

**Example 1:** to perform zero-span calibration check once per day at 10:30 pm, 12/20/98.

- 1) MODE: ZERO-HI
- 2) TIMER ENABLE: ON
- 3) STARTING DATE: 12/20/98
- 4) STARTING TIME: 22:30
- 5) DELTA DAYS: 1
- 6) DELTA TIME: 00:00
- 7) DURATION: 15.0 MINUTES
- 8) CALIBRATE: OFF

**Example 2:** to perform zero calibration adjust once per day retarding 15 minutes everyday starting at 11:30 pm, 12/20/98.

- 1) MODE: ZERO
- 2) TIMER ENABLE: ON
- 3) STARTING DATE: 12/20/98
- 4) STARTING TIME: 23:30
- 5) DELTA DAYS: 0
- 6) DELTA TIME: 23:45
- 7) DURATION: 15.0 MINUTES
- 8) CALIBRATE: ON

**Example 3:** to perform zero-span calibration check once per day at 10:30 pm and zero calibration adjust once per week starting at 11:30 PM, 12/20/98.

1. Select any one of SEQx and program as example 1.
2. Select any other SEQx and program as following; Always avoid setting two or more sequences at the same time of the day.
  - 1) MODE: ZERO
  - 2) TIMER ENABLE: ON
  - 3) STARTING DATE: 12/20/98
  - 4) STARTING TIME: 23:30
  - 5) DELTA DAYS: 7
  - 6) DELTA TIME: 00:00
  - 7) DURATION: 15.0 MINUTES
  - 8) CALIBRATE: ON

## 6.5 Permeation Tube (used with IZS option)

SO<sub>2</sub> is normally a gas at room temperature and pressure, but can be liquefied at moderate pressures. The permeation tube consists of a small container of SO<sub>2</sub> liquid, with a small window of PTFE which is permeable to SO<sub>2</sub>. The gas slowly permeates through the window at a rate in the nanogram/min range. If the tube is kept at constant temperature, usually about 50°C, the device will provide a stable source of SO<sub>2</sub> gas for a year or more. **The IZS permeation tube is intended to be used as a periodic span check and is not to be used as a calibration device.** See below for permeation tube ordering information.

The permeation tube SO<sub>2</sub> concentration is determined by the permeation tube specific output (ppb @ 1 slpm @ 50°C), the permeation tube temperature (°C) and the air flow across it (slpm). The specific output is a fixed function of the permeation tube and is noted on shipping container.

The temperature is set at 50.0°C. Check SETUP-MORE-VARS and scroll to the IZS\_SET variable to verify that the temperature is properly set. It should be set to 50°C with over-and-under temperature warnings set at 49°C and 51°C. There is a 50 cc/min purge flow across the permeation tube at all times to prevent build-up of SO<sub>2</sub> gas in the tubing.

If desired, the output of the permeation tube can be adjusted by adjusting the oven temperature up or down slightly. The adjust increment is 0.1°C to facilitate small adjustments of the setpoint temperature.

When the IZS system is in SPAN mode, the flow across the permeation tube is the sum of the reaction cell flow and the purge flow, which is about 700 cc/min. The gas concentration can be calculated using following equation;

$$C = \frac{PxKm}{F}$$

where

P=permeation rate, ng/min.@ 50°C.

Km=(24.46)/molecular weight, where 24.46 is the molar volume in liters @ 25°C,  
760mmHg            Km for SO<sub>2</sub>=0.382, H<sub>2</sub>S=0.719.

F=total flow rate (sum of sample flow and purge flow), cc/min.

C=concentration, ppm.

Suggested permeation tubes:

SO <sub>2</sub> Permeation tube	uncertified 0.4ppm @ 0.7 lpm
SO <sub>2</sub> Permeation tube	certified 0.4ppm @ 0.7 lpm
SO <sub>2</sub> Permeation tube	certified 0.8ppm @ 0.7 lpm
SO <sub>2</sub> Permeation tube	uncertified 0.8ppm @ 0.7 lpm

Teledyne API recommends that you purchase replacement permeation tubes from:

VICI METRONICS  
2991 Corvin Drive  
Santa Clara, CA 95051 USA  
Phone 408-737-0550 Fax 408-737-0346

The M100A uses 700 cc/min of zero air over the perm tube. Therefore you should order a permeation tube with a SPECIFIC OUTPUT of 350 to 450 ppb at 0.7 liter/minute. This will give you a IZS Span response of 80 to 90% of full scale in the 500 ppb range. Refer to the above equation for calculating other concentrations and instrument flow rates.

Once the Analyzer has stabilized, the response to the permeation tube is not expected to change more than  $\pm 5\%$ . If, during a periodic span check, the response varies by more than 5%, or more importantly, shows drift, then there is a problem with the Analyzer or permeation tube.

**CAUTION**

**Avoid turning off the analyzer with perm tube inside of the analyzer for more than an hour. This will cause to contaminate the analyzer with saturated perm tube gas. When transporting the analyzer, remove the perm tube from the oven and store it inside of the shipping container in safe cool place.**



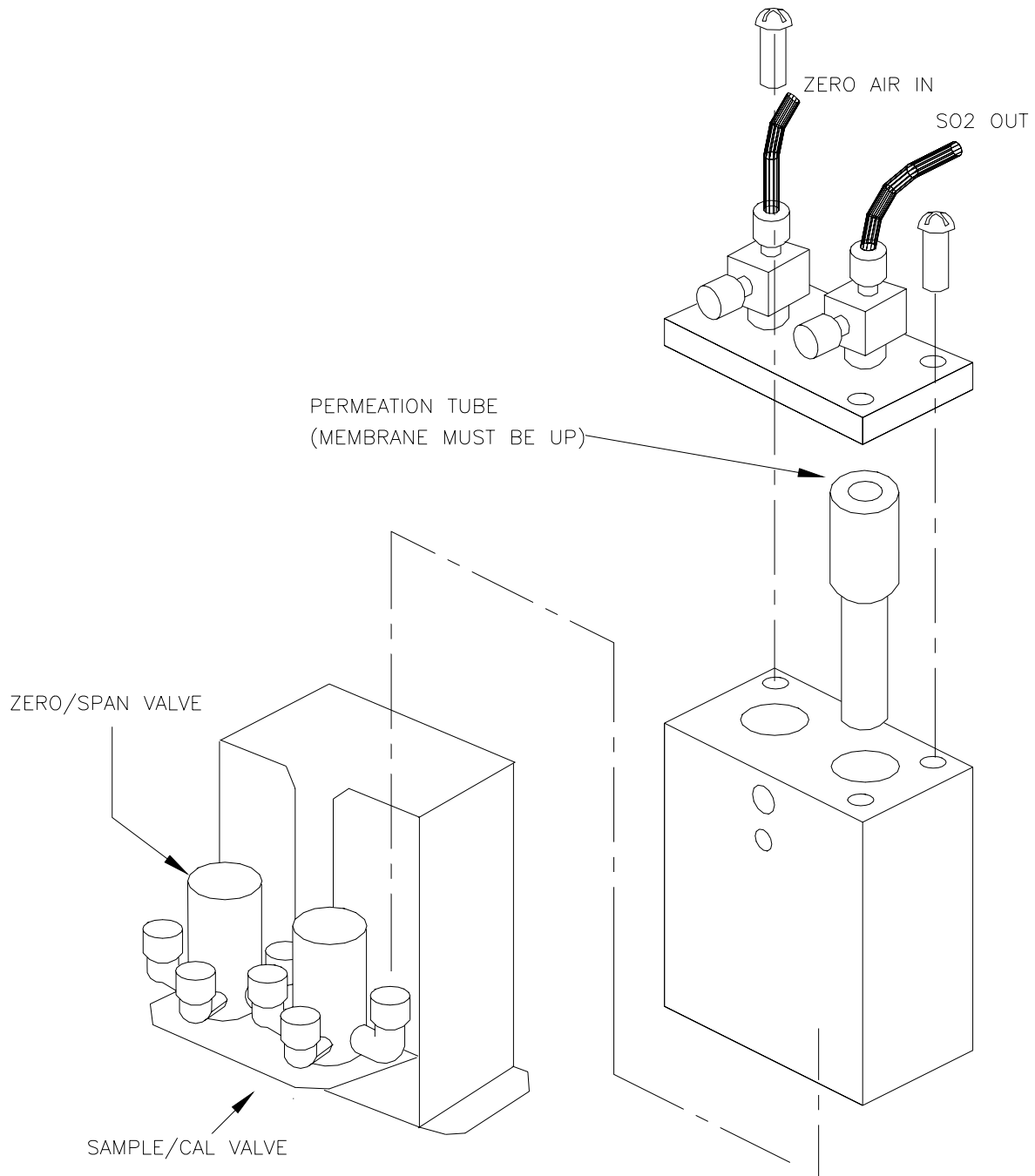

**Figure 6-1: Permeation Tube Installation**

## 6.6 4-20 mA, Current Loop Output

The current loop option replaces the voltage output of the instrument with an isolated 4-20 mA current output. The current outputs come out on the same terminals that were used for voltage outputs, see Figure 2-2. The REC and DAS outputs have current loop capabilities. See Troubleshooting Section 9.3.4.4 for electrical specifications and refer drawings 01471 and 01248 for the jumper settings.

## 6.7 Status Output

The status output is an option that reports Analyzer conditions via contact closures on the rear panel. The closures are available on a 50 pin connector on the rear panel. The contacts are NPN transistors which can pass 50 ma of direct current. The pin assignments are listed in Table 6-3 below.

**Table 6-3: Status Output Pin Assignments**

OUTPUT #	PIN #	DEFINITION	CONDITION
1	1(-),2(+)	ZERO CAL	CLOSED IN ZERO CAL
2	3(-),4(+)	SPAN CAL	CLOSED IN SPAN CAL
3	5(-),6(+)	FLOW ALARM	CLOSED IF FLOW WARNING
4	7(-),8(+)	TEMP ALARM	CLOSED IF ANY TEMP WARNING
5	9(-),10(+)	DIAG MODE	CLOSED IN DIAG MODE
6	11(-),12(+)	POWER OK	CLOSED IF SYSTEM POWER OK
7	21(-),22(+)	SYSTEM OK	CLOSED IF SYSTEM OK
8	19(-),20(+)	HVPS ALARM	CLOSED IF HVPS WARNING
9	13(-),14(+)	SPARE	
10	23(-),24(+)	HIGH RANGE	CLOSED IF HIGH PMT RANGE
11	25(-),26(+)	SHUTTER	CLOSED IF SHUTTER WARNING
12	27(-),28(+)	UV LAMP ALARM	CLOSED IF UV LAMP WARNING

The Status Board schematic can be found in the Appendix Drawing 01087.

## 6.8 RS-232 Interface

The RS-232 communications protocol allows the instrument to be connected to a wide variety of computer based equipment. The interface provides two basic functions in the M100A.

1. First is a comprehensive command interface for operating and diagnosing the analyzer. This interface has in fact more capabilities than the front panel keyboard.
21. The interface can provide an audit trail of analyzer events. In this function the port sends out messages about instrument events like calibration or warning messages. If these messages are captured on a printer or remote computer, they provide a continuous audit trail of the analyzers operation and status.

### 6.8.1 Setting Up the RS-232 Interface

The baud rate is set from the front panel by SETUP-MORE-COMM-BAUD. Select the baud rate appropriate for your application, 300, 1200, 2400, 4800, 9600, 19.2K. **It is important to note that the other device must have identical settings in order for the communications to work correctly.**

Second is physical wiring of the analyzer to the other unit. We have incorporated into the Analyzer LED's that signal the presence of data on the communications lines, and also jumper blocks to easily re-configure the analyzer from DCE to DTE if necessary (see drawing #01115). In addition the front panel diagnostics allow test data streams to be sent out of the port on command. This flexibility and diagnostic capability should simplify attaching our equipment to other computers or printers. If problems occur, see the Troubleshooting Section 9.3.2.

#### Setup from the Front Panel

There are 2 additional RS-232 setups that can be done via the front panel.

1. Set the Instrument ID number by SETUP-MORE-COMM-ID, and enter a 4 digit number from 0000-9999. This ID number is part of every message transmitted from the port.
22. Set the RS-232 mode bit field in the VARS menu. To get to the variable press, SETUP-MORE-VARS-ENTR and scroll to RS232\_MODE, then press EDIT. The possible values are:

**Table 6-4: RS-232 Port Setup - Front Panel**

Decimal Value	Description
1	Turns on quiet mode (messages suppressed)
2	Places analyzer in computer mode (no echo of chars)
4	Enables Security Features (Logon, Logoff)
8	Enables RS-232 menus display on M100A front panel display
16	Enables alternate protocol and setup menu
32	Enables multi-drop support for RTS

**NOTE**

**To enter the correct value, ADD the decimal values of the features you want to enable. For example if LOGON and front panel RS-232 menus were desired the value entered would be 4 + 8 = 12.**

**Security Feature**

The RS-232 port is often connected to a public telephone line which could compromise instrument security. If the LOGON feature is implemented the port has the following attributes:

1. A password is required before the port will operate.
2. If the port is inactive for 1 hour, it will automatically LOGOUT.
3. If not logged on, the only command that is active is the '?'. If this command is issued the M100A will respond with MUST LOG ON.
4. The following messages will be given at logon.
5. LOG ON SUCCESSFUL - Correct password given
6. LOG ON FAILED - Password not given or incorrect
7. LOG OFF SUCCESSFUL - Logged off

The RS-232 LOGON feature must be enabled from the front panel by setting bit 4. See Table 6-4. Once the feature is enabled, to logon type:

LOGON 940331

940331 is the default password. The password can be changed to any number from 0 to 999999 by the variable RS232\_PASS. To change the password enter the command

```
V RS232_PASS=xxxxxx
```

which sets the password to the value xxxxxx.

### **Protocol of Port communication**

The RS-232 interface has two protocols of communication, because if the port is attached to a computer it needs to have different characteristics than if used interactively. Consequently, there are two primary styles of operation: terminal mode and computer mode.

When an operator is communicating with the analyzer via a terminal, the analyzer should be placed into **TERMINAL MODE**, which echoes keystrokes, allows editing of the command line using the backspace and escape keys, and allows recall of the previous command. When a host computer or data logger is connected to the analyzer, it should be placed into **COMPUTER MODE**, which does not echo characters received or allow the special editing keys. See Table 6-5 for relevant commands.

**Table 6-5: RS-232 Switching From Terminal Mode to Computer Mode**

<b>Key</b>	<b>Function</b>
Control-T (ASCII 20 decimal)	Switch to terminal mode (echo, edit)
Control-C (ASCII 3 decimal)	Switch to computer mode (no echo, no edit)

If the command line doesn't seem to respond to keystrokes or commands, one of the first things you should do is send a Control-T to switch the command line interface into terminal mode. Also, some communication programs remove CTRL-T and CTRL-C characters from the byte stream, therefore these characters will not be sent to the analyzer. Check your communications program owners manual.

### **Entering Commands in Terminal Mode**

In terminal mode, all commands must be terminated by a carriage return; commands are not processed until a carriage return is entered. While entering a command you may use the following editing keys:

**Table 6-6: RS-232 Terminal Mode Editing Keys**

<b>Key</b>	<b>Function</b>
CR (carriage return)	Execute command
BS (backspace)	Backspace one character to the left
ESC (escape)	Erase entire line
Control-R (ASCII 18 decimal)	Recall previous command
Control-E (ASCII 5 decimal)	Recall and execute previous command

Commands are not case-sensitive; you should separate all command elements (i.e. keywords, data values, etc.) by spaces.

Words such as T, SET, LIST, etc. are called keywords and are shown on the help screen in uppercase, but they are not case-sensitive. You must type the entire keyword; abbreviations are not accepted.

**OBTAINING HELP**

**Typing "?" followed by Return or Enter will cause a help screen to be displayed.**

## 6.8.2 Command Summary

The information contained in the rest of this section covers all of the normal commands that are required to operate the instrument from a remote terminal. If you are going to be writing computer programs to communicate with the M100A (i.e., operating the port in COMPUTER MODE) we suggest that you order a supplementary manual "The RS-232 Interface", Teledyne API part number 01350. This manual shows additional features of the port designed to support a computer driven interface program.

**Table 6-7: RS-232 Command Summary**

<b>Commands</b>	<b>Definition</b>
?	Print help screen
T SET ALL	Enable display of all test variables during T LIST
T SET name	Display only NAME during T LIST
T LIST [ALL]	Print all test variables enabled with T SET or ALL warnings
T name	Print single test, "name" from Table 6-9
T CLEAR ALL	Disable T LIST, use with T SET name
W SET ALL	Enable display of all warnings during W LIST
W LIST [ALL]	Print warnings enabled with W SET or ALL warnings
W name	Print individual "name" warning from Table 6-10
W CLEAR ALL	Disable W LIST, use with W SET
C command	Execute calibration "command" from Table 6-12
D LIST	Prints all I/O signal values
D name	Prints single I/O signal value/state
D name=value	Sets variable to new "value"
D LIST NAMES	Lists diagnostic test names
D ENTER name	Enters and starts 'name' diagnostic test
D EXIT	Exits diagnostic mode
D RESET	Resets analyzer(same as power-on)
D RESET RAM	System reset, plus erases RAM. Initializes DAS, SO <sub>2</sub> conc readings, calibration data not affected
D RESET EEPROM	System reset, plus erases EEPROM (RAM_RESET actions + setup variables, calibration to default values)
V LIST	Print all easy variable names from Table 9-5
V name	Print individual "name" variable
V name=value	Sets variable to new "value"
V CONFIG	Print analyzer configuration

**Table 6-8: RS-232 Command Summary**

<b>Terminal Mode Editing Keys</b>	<b>Definition</b>
V MODE	Print current analyzer mode
BS	Backspace
EXC	Erase line
^R	Recall last command
^E	Execute last command
CR	Execute command
^C	Switch to computer mode
<b>Computer Mode Editing Keys</b>	<b>Definition</b>
LF	Execute command
^T	Switch to terminal mode
<b>Security Features</b>	<b>Definition</b>
LOGON password	Establish connection to analyzer
LOGOFF	Disconnect from analyzer

### General Output Message Format

Reporting of status messages for use as an audit trail is one of the two principal uses for the RS-232 interface. You can effectively disable the asynchronous reporting feature by setting the interface to quiet mode. All messages output from the analyzer (including those output in response to a command line request) have the format:

X DDD:HH:MM IIII MESSAGE

X is a character indicating the message type, as shown in the table below.

DDD:HH:MM is a time-stamp indicating the day-of-year (DDD) as a number from 1 to 366, the hour of the day (HH) as a number from 00 to 23, and the minute (MM) as a number from 00 to 59.

IIII is the 4-digit machine ID number.

MESSAGE contains warning messages, test measurements, DAS reports, variable values, etc.

The uniform nature of the output messages makes it easy for a host computer to parse them.

**Table 6-9: RS-232 Interface Command Types**

First Character	Message Type
C	Calibration status
D	Diagnostic
R	DAS report
T	Test measurement
V	Variable
W	Warning

There are 6 different types of messages output by the M100A. They are grouped below by type in Table 6-9 - Table 6-14. The meanings of the various messages are discussed elsewhere in the manual. The TEST, DIAGNOSTIC and WARNING messages are discussed in Section 9.1, 9.2, 9.3. DAS and VARIABLES are discussed in Section 5.3.3 and 5.3.9 CALIBRATE is discussed in Section 7.

### 6.8.3 TEST Commands and Messages

**Table 6-10: RS-232 Test Messages**

Name	Message	Description
RANGE <sup>1</sup>	RANGE=xxxxx PPB <sup>2</sup>	Analyzer range
STABILITY	STABIL=xxxx.x PPB	Std. Deviation of last 25 SO <sub>2</sub> concentration values
SAMPPRESS	PRES=xxx.x IN-HG-A	Sample pressure
SAMPFLOW	SAMPLE FL=xxx CC/M	Sample flow rate
PMTDET	PMT=xxxxxx MV	PMT output
UVDET	UV LAMP=xxxx MV	Instantaneous UV lamp reading
STRAYLIGHT	STR LGT=xxx.x PPB	Stray light level
DARKPMT	DRK PMT=xx.x MV	PMT dark current in MV
DARKLAMP	DRK LMP=xx.x MV	UV detector dark current in MV
SLOPE	SLOPE=x.xxx	Calibration slope parameter
OFFSET	OFFSET=xxx.x MV	Calibration offset parameter
HVPS	HVPS=xxxxx V	High voltage power supply
DCPS	DCPS=xxxxxx MV	DC power supply
RCELLTEMP	RCELL TEMP=xxx C	Reaction cell temperature
BOXTEMP	BOX TEMP=xxx C	Internal box temperature
PMTTEMP	PMT TEMP=xxx C	PMT temperature
IZSTEMP <sup>3</sup>	IZS TEMP=xxxx C	IZS temperature
TESTCHAN <sup>4</sup>	TEST=xxxx.x MV	Test channel output
CLOCKTIME	TIME=HH:MM:SS	Time of day

<sup>1</sup>Displayed when single or autorange is enabled.

<sup>2</sup>Depends on which units are currently selected.

<sup>3</sup>Only if option installed.

<sup>4</sup>Only if test channel selected.

The T **command** lists TEST messages. Examples of the T command are:

T LIST	Lists test messages currently enabled with T SET
T LIST ALL	Lists all test messages
T RCELLTEMP	Prints the temperature of the reaction cell
T SO2CONC	Prints SO <sub>2</sub> concentration message
T LAMP RATIO	Prints Lamp Ratio

### 6.8.4 WARNING Commands And Messages

**Table 6-11: RS-232 Warning Messages**

Name	Message	Description
WSYSRES	SYSTEM RESET	Analyzer was reset/powerd on
WRAMINIT	RAM INITIALIZED	RAM was erased
WSAMPFLOW	SAMPLE FLOW WARNING	Sample flow out of spec.
WSAMPPRESS	SAMPLE PRESSURE WARNING	Sample pressure below 15" Hg or above 35" Hg
WUVLAMP	UV LAMP WARNING	UV lamp output is below 600mV or above 4995mV or PMT above 4995mV
WPMTTEMP	PMT TEMP WARNING	PMT temperature too high or too low
WSHUTTTER	SHUTTER WARNING	Shutter not functioning
WRCELLTEMP	RCELL TEMP WARNING	Reaction cell temp. out of spec.
WBOXTEMP	BOX TEMP WARNING	Box temperature too high or too low
WIZSTEMP	IZS TEMP WARNING	IZS temp. out of spec.
WDYNZERO	CANNOT DYN ZERO	Dynamic zero cal. out of spec.
WDYNSPAN	CANNOT DYN SPAN	Dynamic span cal. out of spec.
WHVPS	HVPS WARNING	HVPS too high or too low
WVFDDET	V/F NOT INSTALLED	A/D board not installed or broken
WDCPS	DCPS WARNING	DC power supply output below 2300mV or above 2700mV

Whenever a warning message is reported on the analyzer display, if the RS-232 interface is in the normal mode (i.e. not in quiet mode) the warning message is also sent to the RS-232 interface. These messages are helpful when trying to track down a problem with the analyzer and for determining whether or not the DAS reports are actually valid. The warning message format is for example:

W 194:11:03 0000 SAMPLE FLOW WARNING

The format of a warning command is W command. Examples of warning commands are:

W LIST	List all current warnings
W CLEAR ALL	Clear all current Warnings

Individual warnings may be cleared via the front panel or the command line interface. To clear the sample flow warning shown above the command would be:

W WSAMPFLOW

## 6.8.5 CALIBRATION Commands and Messages

**Table 6-12: RS-232 Calibration Messages**

Message	Description
START ZERO CALIBRATION	Beginning IZS zero calibration
FINISH ZERO CALIBRATION, SO <sub>2</sub> <sup>1</sup> =xxxxx PPB	Finished IZS zero calibration
START SPAN CALIBRATION	Beginning IZS span calibration
FINISH SPAN CALIBRATION, SO <sub>2</sub> <sup>1</sup> =xxxxx PPB	Finished IZS span calibration
START MULTI-POINT CALIBRATION	Beginning multi-point calibration
FINISH MULTI-POINT CALIBRATION	Finished multi-point calibration
<sup>1</sup> Depends on which units are currently selected.	

Whenever the analyzer starts or finishes an IZS calibration, it issues a status report to the RS-232 interface. If the RS-232 interface is in the normal mode, these reports will be sent. Otherwise, they will be discarded. The format of these messages is:

C DDD:HH:MM IIII CALIBRATION STATUS MESSAGE

An example of an actual sequence of calibration status messages is:

C DDD:HH:MM IIII START MULTI-POINT CALIBRATION

C DDD:HH:MM IIII FINISH MULTI-POINT CALIBRATION

There are several methods of both checking the calibration and calibrating the M100A, these are discussed in Section 7. C LIST lists the calibration commands available. The C command executes a calibration command, which may be one of the following:

**Table 6-13: RS-232 Calibration Commands**

<b>Command</b>	<b>Description</b>
C LIST	List calibration commands
C ZERO	Start remote zero calibration
C SPAN	Start remote span calibration
C COMPUTE ZERO	Adjust remote zero calibration
C COMPUTE SPAN	Adjust remote span calibration
C EXIT	Terminate remote zero or span calibration
C ABORT	Abort calibration sequence
C ASEQ X	Initiate automatic sequence X if previously setup

### **6.8.6 DIAGNOSTIC Commands and Messages**

When Diagnostic mode is entered from the RS-232 port, the diagnostic mode issues additional status messages to indicate which diagnostic test is currently selected. Examples of Diagnostic mode messages are:

D DDD:HH:MM IIII ZERO VALVE=ON

D DDD:HH:MM IIII ENTER DIAGNOSTIC MODE

D DDD:HH:MM IIII EXIT DIAGNOSTIC MODE

The following is a summary of the Diagnostic commands.

**Table 6-14: RS-232 Diagnostic Command Summary**

<b>Command</b>	<b>Description</b>
D LIST	Prints all I/O signal values. See Table 9-4 for Sig I/O definitions.
D name=value	Examines or sets I/O signal. For a list of signal names see Table 9-4 in Section 9. Must issue D ENTER SIG command before using this command.
D LIST NAMES	Prints names of all diagnostic tests
D ENTER SIG D ENTER OT D ENTER ET D ENTER TASK	Executes SIGNAL I/O diagnostic test. Executes Optic Test diagnostic test. Executes Elect Test diagnostic test. Displays a listing of the tasks and their status. Use D EXIT to leave these diagnostic modes.
D EXIT	Must use this command to exit SIG, ET or OT Diagnostic modes
D RESET	Resets analyzer software. (Same as power on.)
D RESET RAM	Resets analyzer software and erases RAM. Erases SO <sub>2</sub> conc values. Keeps setup variables and calibration. (Same as installing new software version.)
D RESET EEPROM	Resets analyzer software and erases RAM and EEPROM. Returns all setup variables to factory defaults, resets calibration value.

## 6.8.7 DAS Commands and Reports

### RS-232 Commands

In addition to accessing the data acquisition system and the stored data from the instrument front panel, you can also access the data acquisition and the stored data from the RS-232 interface.

There are two RS-232 commands, listed in the table below.

**Table 6-15: RS-232 DAS Commands**

<b>RS-232 DAS Commands</b>	
<b>Command</b>	<b>Description</b>
D [id] PRINT ["name"]	Prints specified data channel's properties
D [id] REPORT "name" [RECORDS=number] [COMPACT VERBOSE]	Prints the data for the specified data channel

In all of the commands, brackets ([ ]) denote optional parameters. The ID parameter is the instrument ID, useful when the multi-drop protocol is being used. The NAME parameter is the data channel's name. It must be enclosed in quotes (i.e. D PRINT "CONC").

The RECORDS parameter of the REPORT command indicates how many records from the most recent record and prior to print. If the RECORDS parameter is not specified, all of the records are printed. The COMPACT and VERBOSE parameters of the REPORT command specify the report format.

### **RS-232 Reports**

There are two basic kinds of RS-232 reports: data channel summary report, and data reports.

#### **Data Channel Summary Format:**

When you press the **PRNT** button in the data channel edit menu, a report like the following is printed on the RS-232 channel:

SETUP PROPERTIES FOR CONC:

NAME: CONC

EVENT: ATIMER

STARTING DATE: 25-JUL-96

SAMPLE PERIOD: 000:00:01

REPORT PERIOD: 000:00:05

NUMBER OF RECORDS: 800

RS-232 REPORT: ON

COMPACT REPORT: OFF

CHANNEL ENABLED: ON

CAL. HOLD OFF: ON

PARAMETERS: 1

PARAMETER=CONC1, MODE=AVG, PRECISION=1

In this example, the data channel's NAME property is "CONC"; the EVENT property is ATIMER; the PARAMETERS property is 1 (indicating a single parameter); the NUMBER OF RECORDS property is 800, and the RS-232 REPORT property is ON. The list of parameters and their properties is also printed. Each data channel stores its data in a separate file in the RAM disk, and this property shows the file name.

**Data Report Format:**

A data report format looks like the following:

```
D 31:10:06 0412 CONC : AVG CONC1=6.8 PPB
```

This report uses the traditional Teledyne API format of a leading first character (“D” in this example), a time stamp (“31:10:06”), and the instrument ID (“0412”). The other fields in the report are the data channel name (“CONC”), the sampling mode (“AVG”), the parameter (“CONC1”), the parameter value (“6.8”), and the units (“PPB”).

If the RS-232 interface is in the quiet mode, then these reports are not printed, although they can be requested by a user or host computer at a later time.

## 6.8.8 VARIABLES Commands and Messages

**Table 6-16: RS-232 Operating Modes**

Mode	Description
ZERO CAL A	Automatic zero calibration
ZERO CAL R	Remote zero calibration
ZERO CAL M	Manual zero calibration
SPAN CAL A	Automatic span calibration
SPAN CAL R	Remote span calibration
SPAN CAL M	Manual span calibration
M-P CAL	Manual multi-point calibration
DIAG ELEC	Electrical diagnostic test
DIAG OPTIC	Optical diagnostic test
DIAG AOUT	D/A output diagnostic test
DIAG	Main diagnostic menu
DIAG I/O	Signal I/O diagnostic
DIAG RS232	RS232 output diagnostic
DIAG ERASE	Memory erase diagnostic
SETUP x.x	Setup mode (x.x is software version)
SAMPLE A	Sampling; automatic cal. enabled
SAMPLE	Sampling; automatic cal. disabled

The M100A operational modes are listed above. To list the analyzer's current mode type:

V MODE                      Lists M100A current operational mode

See Table 6-14 for list of operational modes and meanings.

### Model 100A Internal Variables

The M100A has a number of internal setup variables. Essentially all of these are set at time of manufacture and should not need to be changed in the field. A list of user accessible variables is shown in Table 9-5.

A list of variables and their settings can be requested over the RS-232 port by:

V LIST                      Lists internal variables and values

The output from this command is quite long and will not be shown here. The general format of the output is:

name = value warning\_lo warning\_hi <data\_lo> <data\_hi>

Where:

name                      = name of the variable  
value                      = current value of variable  
warning\_lo                = lower limit warning (displayed if applicable)  
warning\_hi                = upper limit warning (displayed if applicable)  
data\_lo                    = lower limit of allowable values  
data\_hi                    = upper limit of allowable values

Variables can be changed. **Before changing the settings on any variables, please make sure you understand the consequences of the change. We recommend you call the factory before changing the settings on any variables.** The general format for changing the settings on a variable is:

V LIST name[=value [warn\_lo [warn\_hi]]]

For example to change the warning limits on the box temperature type:

V BOX\_SET 30 10 50

and the CPU should respond with:

V DDD:HH:MM IIII BOX\_SET=30 10 50(0-60)

The CONFIG command lists the software configuration.

For example:

V CONFIG    list software configuration

The format of this listing is shown in the example below.

CONFIG[ 0]=Revision H.7  
CONFIG[ 1]=SO<sub>2</sub> Analyzer  
CONFIG[ 2]=SBC40 CPU

INTENTIONALLY BLANK

## 7 CALIBRATION AND ZERO/SPAN CHECKS

There are several ways to check and adjust the calibration of the M100A. These different methods are summarized in the following Table 7-1. In addition, all of the methods described in this section can be initiated and controlled via the RS-232 port, see Section 6.8 for details.

### NOTE

**If you are using the M100A for EPA monitoring, it is recommended to follow the calibration method described in Section 7.8. All other calibration methods, except in Section 7.6, are also applicable to EPA SLAMS if calibrated under the proper conditions as explained in Section 7.8.**

### NOTE

**If there are any problems completing any of the following procedures refer to Section 9.2.8 and 9.2.9 – Unable to Span or Zero**

**Table 7-1: Types of Zero/Span Checks and Calibrations**

Section	Type of Cal or Check	Description
7.1	Manual Z/S Check - Cal gas through sample port	This calibration option expects the calibration gas coming in through the sample port. IZS and Zero/Span valves do not operate.
7.2	Manual Z/S Check or Calibration with Z/S valve Option	How to operate Zero/Span Valve Option. Can be used to check or adjust calibration.
7.3	Manual Z/S Check or Calibration with IZS Option	How to operate IZS Option. Can be used to check or adjust calibration.
7.4	Automatic Z/S Check with Z/S Valves or IZS Option	Operates Z/S valves or IZS once per day to check the calibration.
7.5	Dynamic Z/S Calibration with Z/S Valves or IZS Option	Operates Z/S valves or IZS once per day and adjusts the calibration.
7.6	Calibrate using SO <sub>2</sub> Permeation Tube	Allows calibration using SO <sub>2</sub> gas from the IZS permeation tube.
7.7	Use of Z/S Valve or IZS with Remote Contact Closure	Operates Z/S valves or IZS with rear panel contact closures. Without valves or IZS, can be used to switch instrument into zero or span cal mode. Used for either checking or adjusting zero/span.
7.8	EPA Protocol Calibration	Covers methods to be used if data is for EPA SLAMS monitoring.
7.9	Special calibration requirements for Dual Range or Auto Range	Covers special requirements if using Dual Range or Auto Range.
7.10	Calibration Quality	Information on how to determine if the calibration performed will result in optimum instrument performance.
7.11	References	Contains a list of references on quality control and calibration.

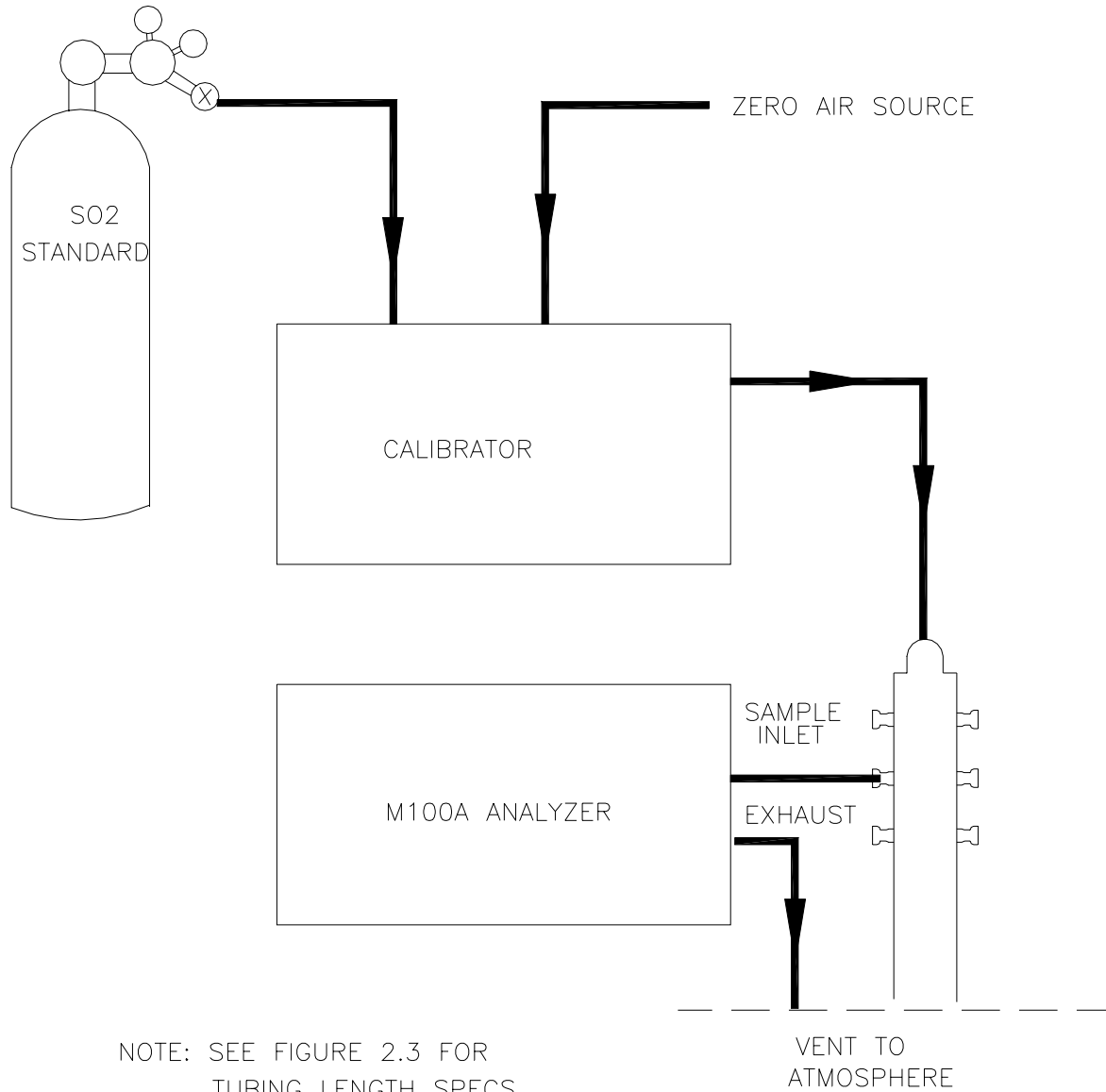

NOTE: SEE FIGURE 2.3 FOR TUBING LENGTH SPECS

NOTE: TUBING 1/4" PTFE OR GLASS

**Figure 7-1: Model 100A Calibration Setup**

## 7.1 Manual Zero/Span Check or Calibration through the Sample Port

The zero and span calibration of the instrument can be checked or adjusted using gases supplied through the normal sample port. This method is often used when the calibration gas is supplied from an external calibrator system.

This mode provides a calibration mechanism if the instrument is purchased without IZS or Zero/Span Valve options.

Since the zero gas concentration is defined as 0 ppb, it is not necessary to enter the expected zero value. Table 7-2 details the zero calibrate procedure with zero gas coming in through the sample port.

**Table 7-2: Manual Zero Calibration Procedure - Zero Gas Through Sample Port**

Step Number	Action	Comment
1.	Press CAL	The M100A enters the calibrate mode from sample mode. The zero gas must come in through the sample port.
2.	Wait 10 min	Wait for reading to stabilize at zero value
3.	Press ZERO	If you change your mind after pressing ZERO, you can still press EXIT here without zeroing the instrument.
4.	Press ENTR	Pressing ENTR actually changes the calculation equations.
5.	Press EXIT	M100A returns to sampling. Immediately after calibration, data is not added to the DAS averages.

Enter the expected SO<sub>2</sub> span gas concentration:

**Table 7-3: Enter Expected Span Gas Concentrations Procedure**

Step Number	Action	Comment
1.	Press CAL-CONC	This key sequence causes the M100A to prompt for the expected SO <sub>2</sub> concentration. Enter the SO <sub>2</sub> span concentration value by pressing the key under each digit until the expected value is set. This menu can also be entered from CALS.
2.	Press ENTR	ENTR stores the expected SO <sub>2</sub> span value.
3.	Press EXIT	Returns instrument to SAMPLE mode.

**Table 7-4: Manual Span Calibration Procedure - Span Gas Through Sample Port**

Step Number	Action	Comment
1.	Press CAL	The M100A enters the calibrate mode. External span gas should be fed to the sample port.
2.	Wait 10 min	Wait for reading to stabilize at span value
3.	Press SPAN	If you change your mind after pressing SPAN, you can still press EXIT here without spanning the instrument.
4.	Press ENTR	Pressing ENTR actually changes the calibration equations and causes the instrument to read the SO <sub>2</sub> span concentrations.
5.	Press EXIT	M100A returns to sampling. Immediately after calibration, data is not added to the DAS averages.

## 7.2 Manual Zero/Span Check or Calibration with Zero/Span Valves Option

The Zero/Span valve option can be operated from the front panel keyboard. In the Zero/Span valve option the zero and span gas come into the valves through ports on the rear panel of the instrument.

**Table 7-5: Manual Zero Calibration Procedure - Z/S Valves**

Step Number	Action	Comment
1.	Press CALZ	The analyzer enters the zero calibrate mode. This switches the sample/cal and zero/span valves to allow zero gas to come in through the zero gas inlet port or the rear panel.
2.	Wait 10 min	Wait for reading to stabilize at zero value
3.	Press ZERO	If you change your mind after pressing ZERO, you can still press EXIT here without zeroing the instrument.
4.	Press ENTR	Pressing ENTR actually changes the calculation equations, forcing the reading to zero.
5.	Press EXIT	M100A returns to sample mode. Immediately after calibration, readings do not go into the DAS averages.

**Table 7-6: Manual Span Calibration Procedure - Z/S Valves**

Step Number	Action	Comment
1.	Press CALS	The M100A enters the calibrate mode from sample mode. This operates the sample/cal and zero/span valves to allow span gas to come in through the cal gas inlet port or the rear panel.
2.	Wait 10 min	Wait for reading to stabilize at span value.
3.	Press SPAN	If you change your mind after pressing SPAN, you can still press EXIT here without spanning the instrument.
4.	Press ENTR	Pressing ENTR actually changes the calculation equations.
5.	Press EXIT	M100A returns to sampling. Immediately after calibration, data is not added to the DAS averages during HOLDOFF period.

## 7.3 Manual Zero/Span Check with IZS Option

The Internal Zero/Span (IZS) system can be operated from the front panel keyboard. When the M100A is in the SAMPLE mode, and the IZS option is installed, the CALS (Calibrate-Span) or CALZ (Calibrate-Zero) buttons will be visible. When the buttons are pressed, valves are switched to allow zero air or SO<sub>2</sub> span gas to be input into the instrument.

To do a manual zero check with the IZS Option, press CALZ, then wait about 10 minutes for the zero reading to stabilize. The zero value in the display, and analog output is the zero value. Press EXIT to return to SAMPLE mode. This procedure does not change the zero calibration of the instrument.

To do a manual SO<sub>2</sub> span check, press CALS, then wait about 10 minutes for the SO<sub>2</sub> reading to stabilize. The concentration value in the display, and analog output is the span value. Press EXIT to return to SAMPLE mode. This procedure does not change the span calibration of the instrument.

## 7.4 Automatic Zero/Span Check

In a typical air monitoring application it is desirable to have the analyzer automatically check (AUTOCAL) its calibration each day. If provided with the proper options, the M100A provides this capability by using the time of day clock to signal the computer system to check operations. When enabled, the instrument software will automatically check zero and span (AUTOCAL) on a timed basis. Optionally, the Z/S cycle can be moved backwards or forwards a fixed time each day (to avoid missing measurements at the same time each day).

Setup of the AUTOCAL is covered in Section 6.4.

## 7.5 Automatic Zero/Span Calibration

The AUTOCAL system described above can also optionally be used to calibrate the instrument on a timed basis. The automatic calibration is enabled by setting CALIBRATE button to ON under each SEQUENCE setup (Refer to Section 6.4).

Before proceeding with enabling Automatic Z/S you must setup the AUTOCAL feature. Enabling this feature is described in Section 6.4.

With automatic calibration turned on, the instrument will re-set the slope and offset values for the SO<sub>2</sub> concentration. This continual re-adjustment of calibration parameters can often mask subtle fault conditions in the analyzer. It is recommended that if Automatic Calibration is enabled, the TEST functions, and SLOPE and OFFSET values in the M100A are checked frequently to assure high quality and accurate data from the instrument.

## 7.6 Calibrate on SO<sub>2</sub> Permeation Tube

If the M100A is equipped with the IZS option, it is possible to span the instrument on the permeation tube (refer to Section 6.5). If this feature is enabled, the instrument internal valves are set so that SO<sub>2</sub> gas is routed through the permeation tube. The software is programmed to use this known SO<sub>2</sub> gas concentration to span the instrument by pressing CALS button. **The IZS permeation tube is intended to be used as a periodic span check and is not to be used as a calibration device.**

### NOTE

**Note that this method of calibration is NOT approved by the USEPA. Permeation tubes are known to change as temperatures are cycled, and as they age. It is recommended that if permeation tube is used, then the instrument calibration be checked frequently by independent means to assure accurate data.**

## 7.7 Use of IZS or Zero/Span Valves with Remote Contact Closure

The Zero/Span valve or IZS options can be operated using Remote Contact Closures provided on the rear panel. See Figure 2-2 for connector location and pinout. When the contacts are closed, the analyzer will switch to zero or span mode. The contacts must remain closed for at least 1 second, and the Analyzer will remain in zero or span mode as long as the contacts are closed. If either DYN\_ZERO or DYN\_SPAN is enabled (refer Table 9-5), the calibration is adjusted at the end of the zero or span time, otherwise zero or span is just checked, not adjusted. To set DYN\_ZERO or DYN\_SPAN, press SETUP-MORE-VARS-ENTR and press NEXT repeatedly until DYN\_ZERO is shown. Press EDIT and toggle OFF (disabled) or ON (enabled).

The CPU monitors these two contact closures and will switch the Analyzer into zero or span mode when the contacts are closed for at least 1 second.

In order to do another remote check, both contact closures should be held open for at least 1 second, then may be set again. Table 7-8 shows what type of check is performed based on the settings of the two contact closures.

**Table 7-7: IZS or Z/S Valves Modes with Remote Contact Closure**

Ext Zero CC	Ext Span CC	Operation
Contact Open	Contact Open	State when in SAMPLE mode, normal monitoring.
Contact Open	Contact Closed	Span check or calibrate *
Contact Closed	Contact Open	Zero check or calibrate *

\* Calibrate only if Dynamic Calibration is enabled (see Table 9-5).

## 7.8 EPA Protocol Calibration

If the M100A is to be used for EPA SLAMS monitoring, it must be calibrated in accordance with the instructions in this section.

In order to insure that high quality, accurate measurements are obtained at all times, the M100A must be calibrated prior to use. A quality assurance program centered on this aspect and including attention to the built-in warning features of the M100A, periodic inspection, regular zero/span checks and routine maintenance is paramount to achieving this.

In order to have a better understanding of the factors involved in assuring continuous and reliable information from the M100A, it is strongly recommended that Publication No. PB 273-518 Quality Assurance Handbook for Air Pollution Measurement Systems (abbreviated, Q.A. Handbook) be purchased from the NTIS (phone 703-605-6000). Special attention should be paid to Section 2.9 which deals with fluorescence based SO<sub>2</sub> analyzers and upon which most of this section is based. Specific regulations regarding the use and operation of ambient sulfur dioxide analyzers can be found in 40 CFR 50 and 40 CFR 58. Both publications are available from the U.S. Government Printing Office (phone 202-512-0327).

### 7.8.1 Calibration of Equipment

In general, calibration is the process of adjusting the gain and offset of the M100A against some recognized standard. The reliability and usefulness of all data derived from any analyzer depends primarily upon its state of calibration. In this section the term dynamic calibration is used to express a multipoint check against known standards and involves introducing gas samples of known concentration into the instrument in order to adjust the instrument to a predetermined sensitivity and to produce a calibration relationship. This relationship is derived from the instrumental response to successive samples of different known concentrations. As a minimum, three reference points and a zero point are recommended to define this relationship. The true values of the calibration gas must be traceable to NIST-SRM's.

All monitoring instrument systems are subject to some drift and variation in internal parameters and cannot be expected to maintain accurate calibration over long periods of time. Therefore, it is necessary to dynamically check the calibration relationship on a predetermined schedule. Zero and span checks must be used to document that the data remains within control limits. These checks are also used in data reduction and validation. Table 7-9 summarizes the initial quality assurance activities for calibrating equipment. Table 7-10 is a matrix for the actual dynamic calibration procedure.

Calibrations should be carried out at the field monitoring site. **The Analyzer should be in operation for at least several hours (preferably overnight) before calibration so that it is fully warmed up and its operation has stabilized.** During the calibration, the M100A should be in the CAL mode, and therefore sample the test atmosphere through all components used during normal ambient sampling and through as much of the ambient air inlet system as is practicable. **If the Instrument will be used on more than one range, it should be calibrated separately on each applicable range (see Section 7.9).** Calibration documentation should be maintained with each analyzer and also in a central backup file.

## 7.8.2 Calibration Gas Sources

### Compressed SO<sub>2</sub> in nitrogen

The NIST-SRM's provide references against which all calibration gas mixtures must be compared (Section 2.0.7, Q.A. Handbook). The procedure requires the comparison of the concentration of a commercial, working calibration standard to an NIST-SRM. This is described in Subsection 7.1 of Section 2.0.7, Q.A. Handbook. Subsections 7.1.4 and 7.1.5 describe the verification and reanalysis of cylinder gases.

### SO<sub>2</sub> permeation tubes

The steps required to compare the concentration of a commercial working calibration standard to an NIST-SRM are described in Subsection 7.2.3 of Section 2.0.7, Q.A. Handbook. See Subsection 7.2.6 for the re-analysis of permeation tubes.

### Dilution air

Zero air (free of contaminants that could cause a detectable response with the Sulfur Dioxide Analyzer) is commercially available, or can be generated by the user. A clean air system utilizing ambient air may be more desirable to use for zero and dilution purposes. If compressed air cylinder is used, the air should have O<sub>2</sub>, N<sub>2</sub>, and CO<sub>2</sub> content similar to that of ambient air and less than 0.1ppm aromatic hydrocarbons.

**Table 7-8: Activity Matrix for Calibration Equipment & Supplies**

Equipment/supplies	Acceptance limits	Frequency and method of measurement	Action if requirements are not met
Recorder	Compatible with output signal of analyzer; min. chart width of 150 mm (6 in) is recommended	Check upon receipt	Return equipment to supplier
Sample line and manifold	Constructed of PTFE or glass	Check upon receipt	Return equipment to supplier
Calibration equipment	Meets guidelines of reference 1 and Section 2.3.2 (Q.A. Handbook)	See Section 2.3.9 (Q.A. Handbook)	Return equipment/supplies to supplier or take corrective action
Working standard SO <sub>2</sub> cylinder gas or SO <sub>2</sub> permeation tube	Traceable to NIST-SRM meets limits in traceability protocol for accuracy and stability (Section 2.0.7, Q.A. Handbook)	Analyzed against NIST-SRM; see protocol in Section 2.0.7, Q.A. Handbook	Obtain new working standard and check for traceability
Zero air	Clean dry ambient air, free of contaminants that cause detectable response with the SO <sub>2</sub> analyzer.	See Section 2.9.2 (Q.A. Handbook)	Obtain air from another source or regenerate.
Record form	Develop standard forms	N/A	Revise forms as appropriate
Audit equipment	Must not be the same as used for calibration	System must be checked out against known standards	Locate problem and correct or return to supplier

**Table 7-9: Activity Matrix for Calibration Procedure**

Equipment/supplies	Acceptance limits	Frequency and method of measurement	Action if requirements are not met
Calibration gases	NIST traceable	Assayed against an NIST-SRM semi-annually, Sec. 2.0.7, (Q.A. Handbook)	Working gas standard is unstable, and/or measurement method is out of control; take corrective action such as obtaining new calibration gas.
Dilution gas	Zero air, free of contaminants	See Section 2.9.2 (Q.A. Manual)	Return to supplier or take appropriate action with generation system
Multi-point calibration	Use calibration procedure in Subsec. 2.2 (Q.A. Handbook); also <u>Federal Register</u>	Perform at least once every quarter or anytime a level span check indicates a discrepancy, or after maintenance which may affect the calibration; Subsec 2.5 (Q.A. Manual)	Repeat the calibration

### 7.8.3 Data Recording Device

Either a strip chart recorder, data acquisition system, digital data acquisition system should be used to record the data from the M100A RS-232 port or analog outputs. If analog readings are being used, the response of that system should be checked against a NIST referenced voltage source or meter. Data recording device should be capable of bi-polar operation so that negative readings can be recorded.

### 7.8.4 Dynamic Multipoint Span Calibration

Dynamic calibration involves introducing gas samples of known concentrations to an instrument in order to adjust the instrument to a predetermined sensitivity and to derive a calibration relationship. A minimum of three reference points and one zero point uniformly spaced covering 0 to 80 percent of the operating range are recommended to define this relationship.

The analyzer's recorded response is compared with the known concentration to derive the calibration relationship.

## 7.8.5 SO<sub>2</sub> Calibration Procedure

There are two calibration procedures for M100A such as dynamic dilution procedure using compressed gas cylinder or using permeation tube. The procedures for multipoint calibration of the SO<sub>2</sub> analyzer are specified in the Code of Federal Regulation.<sup>1</sup> This section applies those general procedures to the case of the M100A.

Calibration must be performed with a calibrator that meets all conditions specified in Subsection 2.9.2 (Q.A. Handbook). The user should be sure that all flow meters are calibrated under the conditions of use against a reliable standard. All volumetric flow rates should be corrected to 25°C (77°F) and 760mm (29.92in) Hg. Make sure the calibration system can supply the range of the concentration at a sufficient flow over the whole range of concentration that will be encountered during calibration.

All operational adjustments to the M100A should be completed prior to the calibration. The following software features must be set into the desired state before calibration.

1. Single range selection. See Section 5.3.4, this manual. If the instrument will be used more than one range, it should be calibrated separately on each applicable range.
2. Automatic temperature/pressure compensation. See Table 9-5.
3. Alternate units, make sure ppb units are selected for EPA monitoring. See Section 5.3.4.2.

The analyzer should be calibrated on the same range for monitoring. If autoranging option is selected, the highest of the ranges will result in the most accurate calibration, and should be used.

### 7.8.5.1 Calibration Using Cylinder Gas Dilution

This calibration procedure consists of diluting a gas cylinder of SO<sub>2</sub> standard with clean dry dilution air.

Possible dilution system is shown in Figure 7-2. Flow controller should be capable of maintaining constant flow rates to within  $\pm 1\%$ . Flowmeters capable of measuring flow rates to within  $\pm 2\%$  are required. NIST-traceable soap bubble flowmeter or wet-test meter are suitable for flow determination. Mixing chamber must be made of glass or Teflon and provide thorough mixing of SO<sub>2</sub> gas with dilution air. Output manifold should be of a sufficient diameter to ensure a minimum pressure drop and must be vented to create ambient pressure at the manifold. Also must have enough flow to prevent back diffusion of ambient air into the manifold. Gas cylinder containing 50 to 100 ppm SO<sub>2</sub> in air is used as the dilution source (refer Table 7-16).

23. Zero calibration procedure.

**Table 7-10: EPA Zero Calibration Procedure**

Step Number	Action	Comment
1.	Press CAL	The M100A enters the calibrate mode from sample mode. Allow the zero gas through the sample port.
2.	Wait 10 min	Wait for reading to stabilize at the zero value.
3.	Press ZERO	To select a zero calibration.
4.	Press ENTR	Pressing ENTR actually changes the equations
5.	Press EXIT	M100A returns to the CAL menu.

1. Adjust the SO<sub>2</sub> concentration to approximately 80% of the URL of the range. The expected SO<sub>2</sub> span concentration can be determined by measuring the cylinder and diluent flows and computing the resulting concentration.

Calculate the expected concentration as follows.

$$[SO_2] = \frac{F_{gas}}{F_{total}} \times [SO_2]_{gas} \text{ ----- Equation 7.1}$$

where;

- [SO<sub>2</sub>]<sub>gas</sub> = cylinder gas concentration, ppm
- F<sub>gas</sub> = SO<sub>2</sub> gas flow rate, cc/min.
- F<sub>total</sub> = total(gas + diluent) flow rate, cc/min.
- [SO<sub>2</sub>] = expected SO<sub>2</sub> concentration, ppm

Enter the expected concentration [SO<sub>2</sub>] using the procedure in Table 7-12. The expected span concentration need not be re-entered each time a calibration is performed unless it is changed.

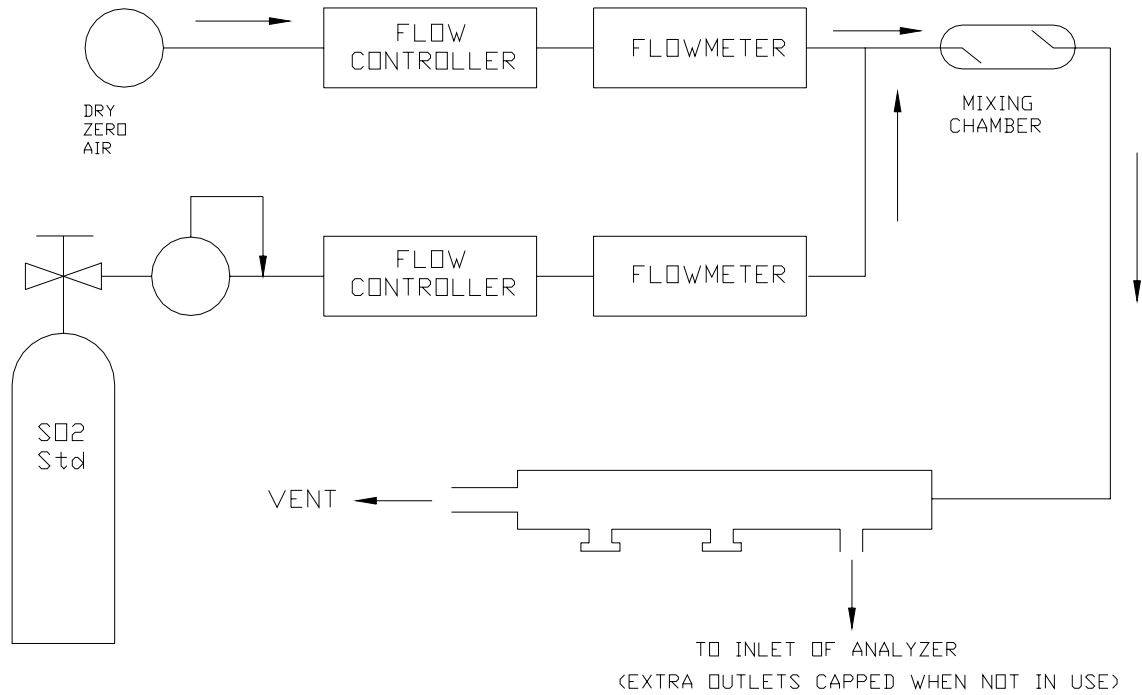

Figure 7-2: Diagram Of Calibration System

Table 7-11: EPA Expected Span Gas Concentration Procedure

Step Number	Action	Comment
1.	Press CAL-CONC	This key sequence causes the M100A to prompt for the expected SO <sub>2</sub> concentration.  Enter the SO <sub>2</sub> span concentration value by pressing the key under each digit until the expected value is set.
2.	Press ENTR	ENTR stores the expected SO <sub>2</sub> span value.
3.	Press EXIT	Returns instrument to SAMPLE mode.

Sample the generated concentration until the SO<sub>2</sub> response is stabilized.

Span the instrument by the following procedure:

**Table 7-12: EPA Span Calibration Procedure**

Step Number	Action	Comment
1.	Press CAL	The M100A enters the calibrate mode from sample mode.
2.	Wait 10 min	Wait for readings to stabilize at span values.
3.	Press SPAN	If you change your mind after pressing SPAN, you can still press EXIT here without spanning the instrument.
4.	Press ENTR	Pressing ENTR actually changes the calculation equations.
5.	Press EXIT	M100A returns to SAMPLE mode.

The analog voltage output should measure approximately 80% of the voltage range selected. (e.g. 4.00VDC if 0-5V output is selected.) The reading on the front panel display should be equal to the expected SO<sub>2</sub> concentration entered in the procedure given in Table 7-12 above. See the Troubleshooting Section 9.2.8 if there are problems. Also see the Calibration Quality Check procedure Section 7.10.

After the zero and the 80% URL points have been set, generate five approximately evenly spaced calibration points between zero and 80% URL without further adjustment to the instrument. Allow the instrument to sample these intermediate concentrations for about 10 minutes each and record the instrument SO<sub>2</sub> response.

Plot the analyzer SO<sub>2</sub> response versus the corresponding calculated concentrations to obtain the calibration relationships. Determine the straight line of best fit ( $y = mx + b$ ) determined by the method of least squares.

After the best-fit line has been drawn for the SO<sub>2</sub> calibration, determine whether the analyzer response is linear. To be considered linear, no calibration point should differ from the best-fit line by more than 2% of full scale.

### 7.8.5.2 Calibration Using Dynamic Permeation Dilution

The procedure for multipoint calibration of an SO<sub>2</sub> analyzer by an SO<sub>2</sub> permeation system are specified in Code of Federal Regulations.<sup>1</sup>

Possible dilution system is shown in Figure 7-3. Permeation chamber temperature must be maintained within  $\pm 0.1^\circ\text{C}$  of accuracy. Should allow a minimum of 24 hours of temperature equilibrium period after power up of the temperature controller. Flow controllers should be capable of maintaining constant flow rate to within  $\pm 1\%$ . Flowmeters capable of measuring flow rates to within  $\pm 2\%$  are required. NIST-traceable soap bubble flowmeter or wet-test meter are suitable for flow determination. Mixing chamber is made of glass and should provide thorough mixing of SO<sub>2</sub> gas with dilution air. Output manifold should be sufficient diameter to ensure a minimum pressure drop and must be vented to create ambient pressure at the manifold. Permeation tube traceability is established by referencing the permeation device to a NIST-SRM (refer to Table 7-16).

1. Zero calibration procedure is identical to Table 7-11.
2. Generate the SO<sub>2</sub> concentration to approximately 80% of the URL of the range.

Calculate the expected concentration as follows.

$$[SO_2] = \frac{P \times 10^3}{F_c + F_d} \times 3.82 \times 10^{-4} \text{ ----- Equation 7.2}$$

[SO<sub>2</sub>] = SO<sub>2</sub> gas concentration, ppm

P = permeation flow rate at the specific temperature, ug·SO<sub>2</sub> /min.

F<sub>c</sub> = carrier flow rate over the permeation tube, SLPM (25°C, 760 mmHg)

F<sub>d</sub> = diluent air flow rate, SLPM (25°C, 760 mmHg)

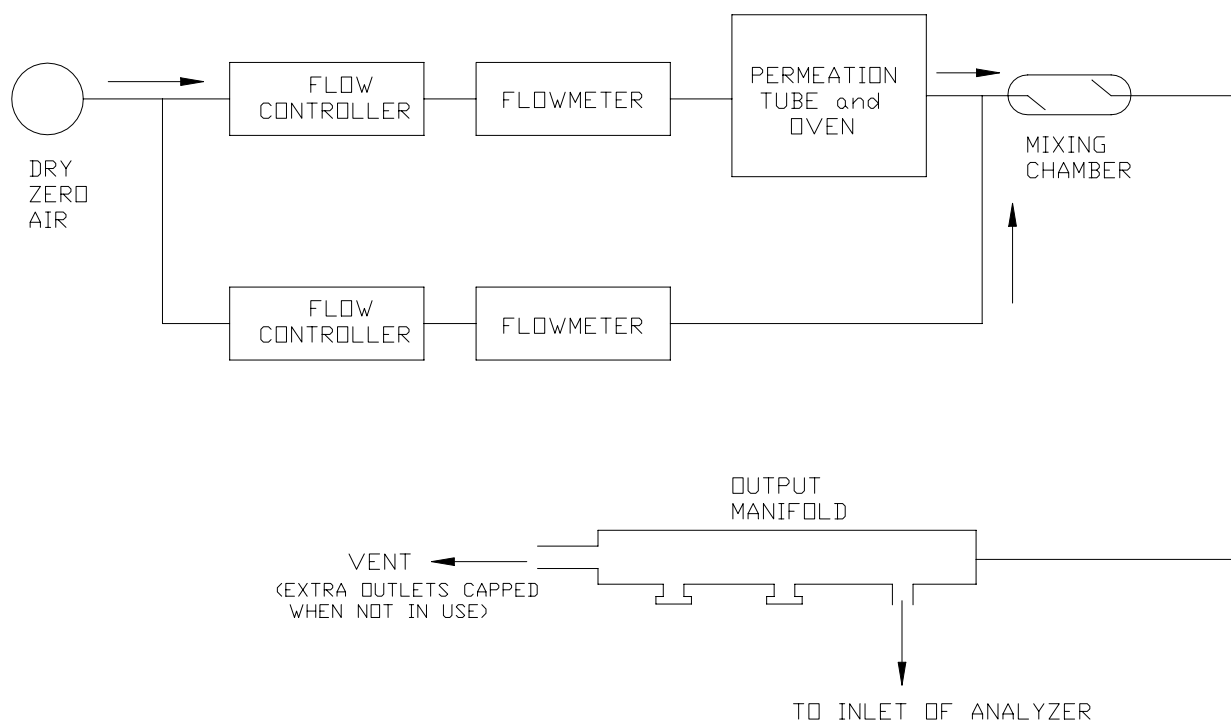

**Figure 7-3: Diagram F Permeation Calibration System**

By rearranging Equation 7.2 it is possible to calculate total air flow which is sum of  $F_c$  and  $F_d$ .

$$F_{total} = F_c + F_d$$

$$F_{total} = \frac{P \times 10^3}{[SO_2]} \times 3.82 \times 10^{-4} \quad \text{Equation 7.3}$$

Total air flow rate should exceed the analyzer's sample flow rate demand by margin of 10% to 50%.

3. Enter the expected concentration  $[SO_2]$  from Equation 7.2 using the procedure in Table 7-12.
4. Sample the generated concentration until the SO<sub>2</sub> response is stabilized.
5. Span the instrument per Table 7-13.

If the expected concentration value is 80% of the full range, then the analog voltage output should measure 80% of the voltage range selected. (e.g. 4.00VDC if 0-5V output is selected.) The reading on the front panel display should be equal to the expected SO<sub>2</sub> concentration entered in the procedure given in step 3 above. See the Troubleshooting Section 9.2.8 if there are problems. Also see the Calibration Quality Check procedure Section 7.10.

24. After the zero and the 80% URL points have been set, determine five approximately evenly spaced points between zero and 80% URL without further adjustment to the instrument. And allow the instrument to sample these intermediate concentrations for about 10 minutes each and record the instrument response.
  6. Plot the analyzer responses versus the corresponding calculated concentrations to obtain the calibration relationship. Determine the straight line of best fit ( $y = mx + b$ ) determined by the method of least squares.
  7. After the best-fit line has been drawn for the SO<sub>2</sub> calibration, determine whether the analyzer response is linear. To be considered linear, no calibration point should differ from the best-fit line by more than 2% of full scale.

## 7.8.6 Calibration Frequency

To ensure accurate measurements of the SO<sub>2</sub> concentrations, calibrate the analyzer at the time of installation, and re-calibrate it:

1. No later than three months after the most recent calibration or performance audit which indicated analyzer calibration to be acceptable.
2. An interruption of more than a few days in analyzer operation.
3. Any repairs which might affect its calibration.
4. Physical relocation of the analyzer.
5. Any other indication (including excessive zero or span drift) of possible significant inaccuracy of the analyzer.

Following any of the activities listed above, the zero and span should be checked to determine if a calibration is necessary. If the analyzer zero and span drifts exceed locally established calibration units or the calibration limits in Section 2.0.9, Subsection 9.1.3 (Q.A. Handbook), a calibration should be performed.

## 7.8.7 Other Quality Assurance Procedures

Essential to quality assurance are scheduled checks for verifying the operational status of the monitoring system. The operator should visit the site at least once each week. It is recommended Level 1 zero and span check conducted on the analyzer every two weeks. Level 2 zero and span checks should be conducted at a frequency desired by the user. Definitions of these terms are given in Table 7-14.

In addition, an independent precision check between 0.08 and 0.10 ppm must be carried out at least once every two weeks. Table 7-15 summarizes the quality assurance activities for routine operations. A discussion of each activity appears in the following sections.

To provide for documentation and accountability of activities, a checklist should be compiled and then filled out by the field operator as each activity is completed.

**Table 7-13: Definition of Level 1 and Level 2 Zero and Span Checks**

(from Section 2.0.9 of Q.A. Handbook for Air Pollution Measurement Systems)

LEVEL 1 ZERO AND SPAN CALIBRATION	LEVEL 2 ZERO AND SPAN CHECK
<p>A Level 1 zero and span calibration is a simplified, two-point analyzer calibration used when analyzer linearity does not need to be checked or verified. (Sometimes when no adjustments are made to the analyzer, the Level 1 calibration may be called a zero/span check, in which case it must not be confused with a Level 2 zero/span check.) Since most analyzers have a reliably linear or near-linear output response with concentration, they can be adequately calibrated with only two concentration standards (two-point concentration). Furthermore, one of the standards may be zero concentration, which is relatively easily obtained and need not be certified. Hence, only one certified concentration standard is needed for the two-point (Level 1) zero and span calibration. Although lacking the advantages of the multipoint calibration, the two-point zero and span calibration--because of its simplicity--can be (and should be) carried out much more frequently. Also, two-point calibrations are easily automated. Frequency checks or updating of the calibration relationship with a two-point zero and span calibration improves the quality of the monitoring data by helping to keep the calibration relationship more closely matched to any changes (drifts) in the analyzer response.</p>	<p>A Level 2 zero and span check is an "unofficial" check of an analyzer's response. It may include dynamic checks made with uncertified test concentrations, artificial stimulation of the analyzer's detector, electronic or other types of checks of a portion of the analyzer, etc.</p> <p>Level 2 zero and span checks are <u>not</u> to be used as a basis for analyzer zero or span adjustments, calibration updates, or adjustment of ambient data. They are intended as quick, convenient checks to be used between zero and span calibrations to check for possible analyzer malfunction or calibration drift. Whenever a Level 2 zero or span check indicates a possible calibration problem, a Level 1 zero and span (or multipoint) calibration should be carried out before any corrective action is taken.</p> <p>If a Level 2 zero and span check is to be used in the quality control program, a "reference response" for the check should be obtained immediately following a zero and span (or multipoint) calibration while the analyzer's calibration is accurately known. Subsequent Level 2 check responses should then be compared to the most recent reference response to determine if a change in response has occurred. For automatic Level 2 zero and span checks, the first scheduled check following the calibration should be used for the reference response. It should be kept in mind that any Level 2 check that involves only part of the analyzer's system cannot provide information about the portions of the system not checked and therefore cannot be used as a verification of the overall analyzer calibration.</p>

### 7.8.8 Summary of Quality Assurance Checks

The following items should be checked on a regularly scheduled basis to assure high quality data from the M100A. See Table 7-14 for a summary of activities also the QA Handbook should be checked for specific procedures.

**Table 7-14: Activity Matrix**

Characteristic	Acceptance limits	Frequency and method of measurement	Action if requirements are not met
Shelter temperature	Mean temperature between 22°C and 28°C (72° and 82°F), daily fluctuations not greater than ±2°C	Check thermograph chart weekly for variations greater than ±2°C (4°F)	<ol style="list-style-type: none"> <li>1. Mark strip chart for the affected time period</li> <li>2. Repair or adjust temperature control</li> </ol>
Sample introduction system	No moisture, foreign material, leaks, obstructions; sample line connected to manifold	Weekly visual inspection	Clean, repair, or replace as needed
Recorder	<ol style="list-style-type: none"> <li>1. Adequate ink &amp; paper</li> <li>2. Legible ink traces</li> <li>3. Correct chart speed and range</li> <li>4. Correct time</li> </ol>	Weekly visual inspection	<ol style="list-style-type: none"> <li>1. Replenish ink and paper supply</li> <li>2. Adjust time to agree with clock; note on chart</li> </ol>
Analyzer operational settings	<ol style="list-style-type: none"> <li>1. TEST measurements at nominal values</li> <li>2. M100A in SAMPLE mode</li> </ol>	Weekly visual inspection	Adjust or repair as needed
Analyzer operational check	Zero and span within tolerance limits as described in Subsec. 9.1.3 of Sec. 2.0.9 (Q.A. Handbook)	Level 1 zero/span every 2 weeks; Level 2 between Level 1 checks at frequency desired analyzer by user	<ol style="list-style-type: none"> <li>1. Find source of error and repair</li> <li>2. After corrective action, re-calibrate analyzer</li> </ol>
Precision check	Assess precision as described in Sec. 2.0.8 and Subsec. 3.4.3 (Ibid.)	Every 2 weeks, Subsec. 3.4.3 (Ibid.)	Calc, report precision, Sec. 2.0.8 (Ibid.)

## 7.8.9 ZERO and SPAN Checks

A system of Level 1 and Level 2 zero span checks (see Table 7-1) is recommended. These checks must be conducted in accordance with the specific guidance given in Subsection 9.1 of Section 2.0.9 (Q.A. Handbook). It is recommended Level 1 zero and span checks conducted every two weeks. Level 2 checks should be conducted in between the Level 1 checks at a frequency desired by the user. Span concentrations for both levels should be between 70 and 90% of the measurement range.

Zero and span data are to be used to:

1. provide data to allow analyzer adjustment for zero and span drift;
2. provide a decision point on when to calibrate the analyzer;
3. provide a decision point on invalidation of monitoring data.

Items 1 and 2 are described in detail in Subsection 9.1.3 of Section 2.0.9 (Q.A. Handbook). Item 3 is described in Subsection 9.1.4 of the same section.

Refer to the Troubleshooting Section 9 of this manual if the instrument is not within the allowed variations.

### 7.8.9.1 Zero/Span Check Procedures

The Zero and Span calibration can be checked a variety of different ways. They include:

1. **Manual Zero/Span Check.**  
Zero and Span can be checked from the front panel keyboard. The procedure is in Section 7.1 of this manual.
2. **Automatic Zero/Span Checks**  
After the appropriate setup, Z/S checks can be performed automatically every night. See Table 6-2 and Section 7.4 of this manual for setup and operation procedures.
3. **Zero/Span checks via remote contact closure**  
Zero/Span checks can be initiated via remote contact closures on the rear panel. See Section 7.7 of this manual.
4. **Zero/Span via RS-232 port**  
Z/S checks can be controlled via the RS-232 port. See Section 6.8.5 of this manual for more details.

### 7.8.9.2 Precision Check

A periodic check is used to assess the data for precision. A one-point precision check must be carried out at least once every 2 weeks on each analyzer at an SO<sub>2</sub> concentration between 0.08 and 0.10 ppm. The analyzer must be operated in its normal sampling mode, and the precision test gas must pass through all filters, scrubbers, conditioners, and other components used during normal ambient sampling. The standards from which precision check test concentrations are obtained must be traceable to NIST-SRM. Those standards used for calibration or auditing may be used.

### 7.8.9.3 Precision Check Procedure

1. Connect the analyzer to a precision gas that has an SO<sub>2</sub> concentration between 0.08 and 0.10 ppm. An SO<sub>2</sub> precision gas may be generated by either the SO<sub>2</sub> gas cylinder or a SO<sub>2</sub> permeation tube. If a precision check is made in conjunction with a zero/span check, it must be made prior to any zero or span adjustments.
2. Allow the analyzer to sample the precision gas until a stable trace is obtained.
3. Record this value. Information from the check procedure is used to assess the precision of the monitoring data; see 40 CFR 58 for procedures for calculating and reporting precision.

### 7.8.10 Recommended Standards for Establishing Traceability

To assure data of desired quality, two considerations are essential: (1) the measurement process must be in statistical control at the time of the measurement and (2) the systematic errors, when combined with the random variation in the measurement process, must result in a suitably small uncertainty.

Evidence of good quality data includes documentation of the quality control checks and the independent audits of the measurement process by recording data on specific forms or on a quality control chart and by using materials, instruments, and measurement procedures that can be traced to appropriate standards of reference. To establish traceability, data must be obtained routinely by repeat measurements of standard reference samples (primary, secondary, and/or working standards). More specifically, working calibration standards must be traceable to standards of higher accuracy, such as those listed below in Table 7-15.

**Table 7-15: NIST-SRM's Available for Traceability of Calibration and Audit Gas Standards**

NIST-SRM <sup>4</sup>	Type	Nominal concentration
1693	SO <sub>2</sub> in N <sub>2</sub>	50 ppm
1694	SO <sub>2</sub> in N <sub>2</sub>	100 ppm

## Permeation Tubes

NIST-SRM <sup>4</sup>	Type	Permeation rate, ug/min @ 25°C	Concentration, ppm <u>at flow rates of: 1 L/min / 5 L/min</u>
1625	SO <sub>2</sub> permeation tube	2.8	1.07 / 0.214
1626	SO <sub>2</sub> permeation tube	1.4	0.535 / 0.107
1627	SO <sub>2</sub> permeation tube	0.56	0.214 / 0.0428

Cylinders of working gas traceable to NIST-SRM's (called EPA Protocol Calibration Gas) are also commercially available (from sources such as Scott Specialty Gases, etc.).

## 7.9 Special Calibration Requirements for Dual Range or Auto Range

If Dual Range or Auto Range is selected, then it should be calibrated for both Range1 and Range2 separately. Pressing CAL key will prompt #1 and #2 keys for Range1 (Low Range) or Range2 (Hi Range) calibration selection. Select desired range number and press ENTR to proceed to the calibration. Once Range# is selected, the display will show Test Measurements and SO<sub>2</sub> concentration for the corresponding Range#. You must enter expected SO<sub>2</sub> gas concentrations separately per Table 7-3 procedure for each Range #.

For zero calibration allow zero gas through the sample port and proceed to manual zero calibration procedure per Table 7-2, step 2 through step 4. After zero calibration is set, switch to span SO<sub>2</sub> gas to continue for span calibration procedure per Table 7-4 step 2 through step 4. Press EXIT to exit from the current Range.

Repeat above procedure for other Range # by pressing CAL key and selecting Range # as described above. Enter once again corresponding SO<sub>2</sub> gas concentration for selected Range # and continue zero/span calibration for other Range # selected.

M100A with IZS option can be used to calibrate zero/span of one Range #, but not both. Other Range # should be calibrated using external zero/span gas through sample port. Pressing CALZ (for zero) or CALS (for span) keys will lead to show #1 and #2 the same way as CAL key except CALZ is dedicated for zero air calibration while CALS is dedicated for span gas calibration. Zero/span valve option is also treated same as IZS option except external zero/span gas are used for both Range#.

## 7.10 Calibration Quality

After Zero/Span is complete, it is very important to check the QUALITY of the calibration. The calibration of the M100A involves balancing several sections of electronics and software to achieve an optimum balance of accuracy, noise, linearity and dynamic range.

The following procedure compares the Slope and Offset parameters in the equation used to compute the SO<sub>2</sub> concentration. For an explanation of the use of these terms in the concentration calculation see Section 5.2.2.5.

The slope and offset parameters are similar to the span and zero pots on an analog instrument. Just as in the analog instrument, if the slope or offset get outside of a certain range, the instrument will not perform as well.

The offset value gives information about the background signal level. Check the observed offset value against the factory value in Table 2-1. If significantly higher check Section 9.1.6. Increasing readings are a predictor of problems.

**Table 7-16: Calibration Quality Check**

Step Number	Action	Comment
1.	Scroll the TEST function menu until the SLOPE is displayed.	Typical SLOPE value for SO <sub>2</sub> is $1.0 \pm 0.3$ . If the value is not in this range, check Section 9.1.6. If the SLOPE value is in the acceptable range the instrument will perform optimally.
2.	Scroll the TEST function menu until the OFFSET is displayed.	Typical number is between 50mV and 250mV which is mainly the optical system background. If the OFFSET value is outside this range, check Section 9.1.6.

After the above procedure is complete, the M100A is ready to measure sample gas.

## 7.11 References

1. Environmental Protection Agency, Title 40, Code of Federal Regulations, Part 50, Appendix A, Section 10.3.
2. Quality Assurance Handbook for Air Pollution Measurement Systems - Volume II, Ambient Air Specific Methods, EPA-600/4-77-027a, 1977.
25. Catalog of NBS Standard Reference Materials. NBS Special Publication 260, 1975-76 Edition. U.S. Department of Commerce, NBS. Washington, D.C. June 1975. (Tel: 301-975-6776 for ordering the catalog)
3. Quality Assurance Handbook for Air Pollution Measurement Systems - Volume I, Principles. EPA-600/9-76-005. March 1976.

## 8 MAINTENANCE



### NOTE

The operations outlined in this chapter are to be performed by qualified maintenance personnel only.

### 8.1 Maintenance Schedule

**Table 8-1: Preventative Maintenance Schedule**

Item	Maintenance Interval	Reference Section
TEST functions	Check every month	Table 9-1
Zero/Span Calibration	Weekly or as needed	Section 7
Zero/Span checks	Daily	Section 7, Table 6-2
Particulate Filter	Weekly as needed	Figure 8-1
Zero air canister	Refill every 3 months	Section 8.4
Zero Air DFU filter	Change every 12 months	Section 8.4
Reaction cell cleaning	Clean annually and clean as necessary	Section 8.6, Figure 8-3
Sample Flow	Check every 6 months	Figure 8-3, Section 9.2.2
Pneumatic Lines	Examine every 12 months, clean if necessary	Figure 8-3
Factory Calibration	Calibrate each year or after repairs	Section 9.1.6
Leak Check	Check every year	Section 8.8
Pump Diaphragm	Change annually	

## 8.2 Replacing the Sample Particulate Filter

The particulate filter should be inspected often for signs of plugging or contamination. It is also common for dirt particles to absorb SO<sub>2</sub>, thus causing those readings to be lower than the actual value. Very dirty filter can cause serious monitoring problem such as very slow and low response, unable to span, and contamination of the analyzer. The particulate filter should be changed at a minimum every 2 weeks. If instrument is operated under high dust environment, then should replace filter more frequently.

To check and change the filter (refer Figure 8-1):

1. Fold down the M100A front panel.
2. Locate the filter on the left side of the analyzer front panel and visually inspect the filter through the glass window.
3. If the filter appears dirty, unscrew the hold-down ring, remove the Teflon o-ring and then the filter.
4. Replace the filter, being careful that the element is fully seated in the bottom of the holder. Replace the Teflon o-ring with notches upward, then screw on the hold-down ring and hand tighten.

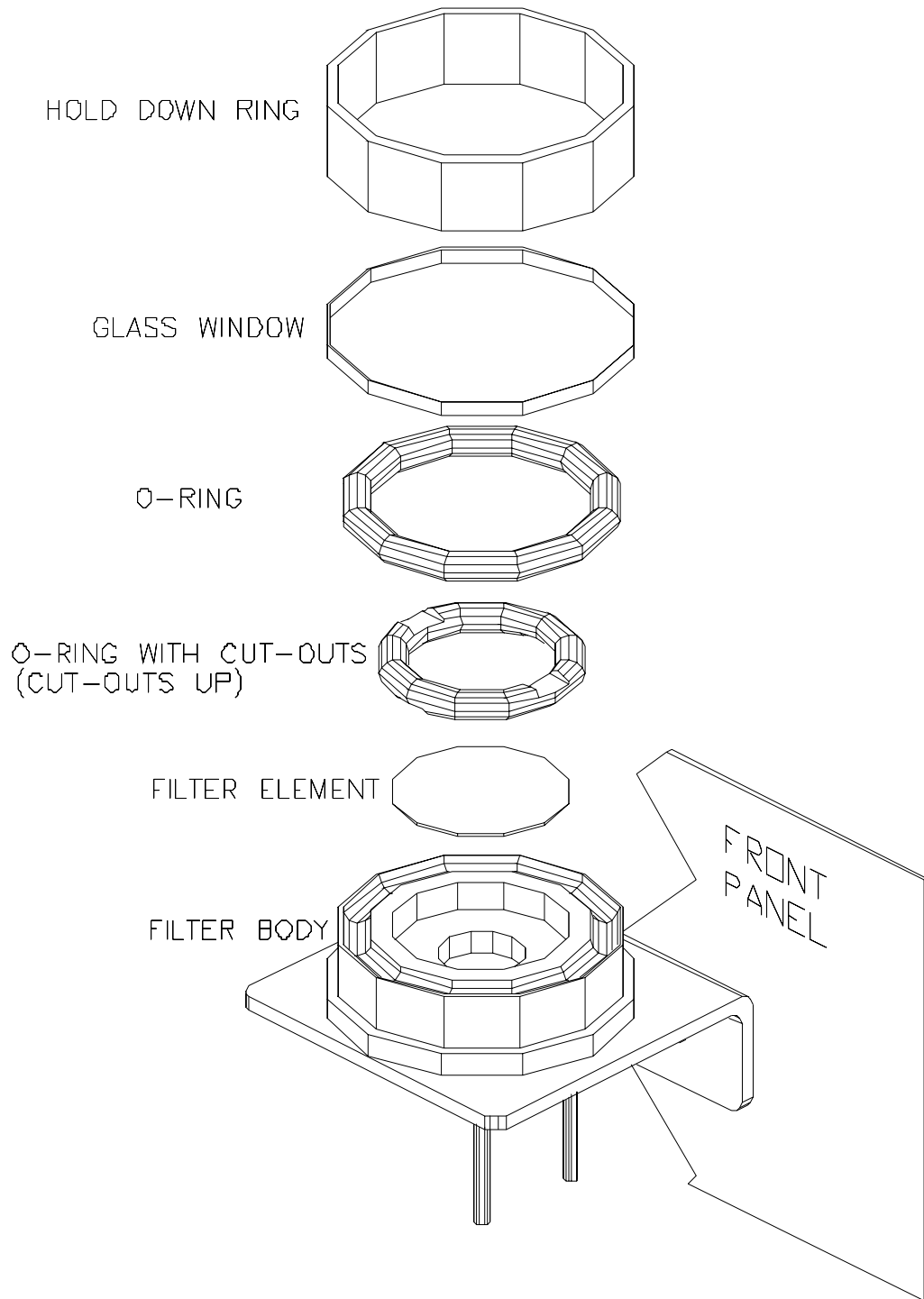

**Figure 8-1: Replacing the Particulate Filter**

## 8.3 Replacing the Permeation Tube (option)

The permeation tube is contained in the oven at the rear left of the instrument, refer to Figure 2-5 for its location.

1. Turn off the instrument power.
2. Remove the rubber insulation from the top of the assembly (refer to Figure 6-1).
3. Remove the oven cover by removing the three screws holding down the cover.
4. Remove the old permeation tube. Install the new permeation tube in the same chamber with the membrane facing UP.
5. Re-assemble the oven and turn on instrument power.

**NOTE:**

Permeation tubes require 48 hours at 50°C to reach a stable output. We recommend waiting this long before any calibration checks, adjustments, or conclusions are reached about the permeation tube. Refer to Section 6.5 regarding permeation tube output concentration.

**CAUTION**

**Avoid turning off the analyzer with perm tube inside of the analyzer for more than an hour. This will cause to contaminate the analyzer with saturated perm tube gas. When transporting the analyzer, remove the perm tube from the oven and store it inside of the shipping container in safe cool place.**



## 8.4 Replacing the IZS Zero Air Scrubber (option)

The IZS zero air scrubber is located at the front of the instrument (see Figure 2-5). Refer to Table 8-1 for recommended replacement interval. The entire cartridge can be replaced, or just the charcoal inside of the cartridge. To replace the scrubber materials:

26. Disconnect the scrubber from the clip of bracket and remove fitting that holds the DFU filter. While removing the cartridge, check the DFU filter for contamination and dirt. Replace it if necessary.
  1. Unscrew the top, remove the felt pad and empty the contents.
  2. Inspect the upper and lower felt pads for signs of plugging, replace if necessary.

3. Replace with charcoal.
4. Re-install felt pad and re-tighten the cap. Make sure the o-ring in the cap is in good shape and squarely seated.
5. **Leak check the assembly**, then re-attach scrubber to fitting and clip on the bracket.

## **8.5 Cleaning Orifice and Orifice Filter**

The sample flow across the internal pneumatic system is fixed by the critical flow control orifice and has no adjustment.

1. Turn off the instrument power.
2. Remove the straight fittings (the far left and far right) only from the vacuum manifold assembly.
3. With a toothpick or paper clip, remove the spring, filter, o-ring , orifice, and the o-ring from each port.
4. Discard the filter.
5. Check the orifice by looking it at the light to see that the orifice itself is open. If it is not open, try cleaning the orifice with a strand of fine wire or immersing in a solvent such as methyl alcohol, or both.
6. If the orifice will not open, replace it.
7. Replace o-rings if they are deformed or suspected not to seat properly.
8. To replace the orifice, start with the o-ring, then orifice (jeweled end faces upstream), o-ring, filter, and finally spring.
9. Retape the fittings with TFE tape, install and tighten.
10. Leak check.

## 8.6 Cleaning the Reaction Cell

The reaction cell should be cleaned whenever troubleshooting points to it as the cause of the trouble (refer Figure 8-2). A dirty cell will cause excessive noise, unstable span or zero, high stray light, or slow response.

Use the following guide:

1. Turn off the instrument power.
2. Remove the three screws at the sensor shock absorber mounts.
3. Tilt the sensor up to provide access to the reaction cell cover.
4. Remove the cover carefully to avoid thermal silicon contamination on the o-ring and the cell.
5. Wipe out the reaction cell with a de-ionized water wetted lintless wipe. Dry with another lintless wipe.
6. Be sure that all lint particles are removed, particularly from the UV lens and PMT filter.
7. Install the cell cover.
8. Install the shock absorber mount screws.
9. Leak-check per Section 8.8.

## 8.7 Pneumatic Line Inspection

Particulate matter and contamination in the pneumatic lines will affect the response of the analyzer. It is important that the pneumatic system be periodically inspected and thoroughly cleaned if necessary. Clean by disassembling and passing methanol through three times. Dry with nitrogen or suitable clean zero air.

Also inspect all pneumatic lines for cracks and abrasion on a regular basis. Replace as necessary. Refer to the pneumatic diagram in Figure 8-3.

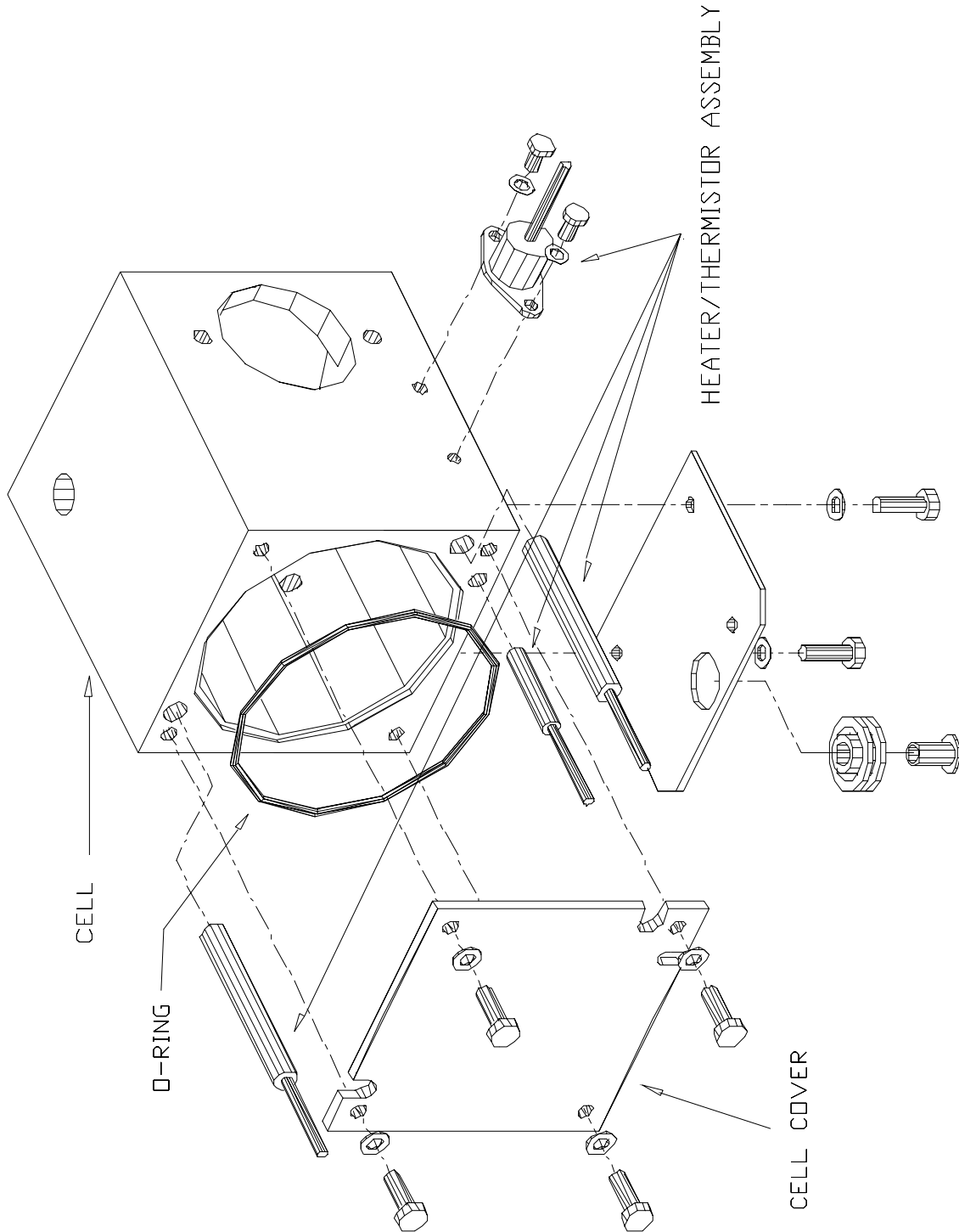
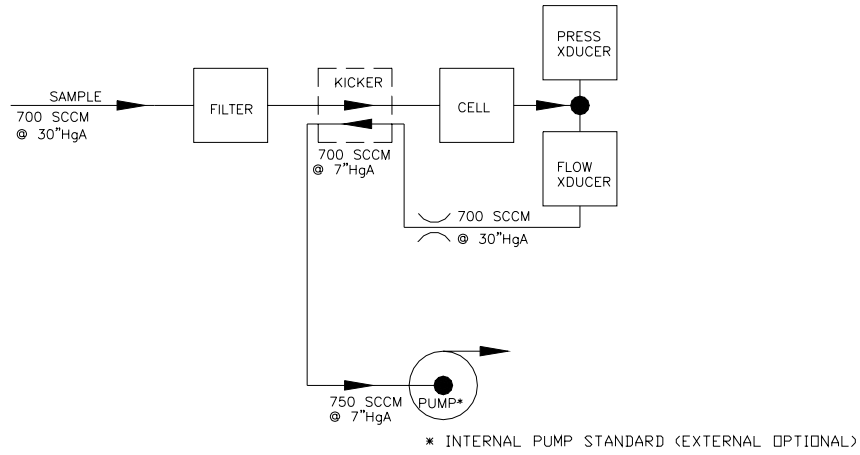
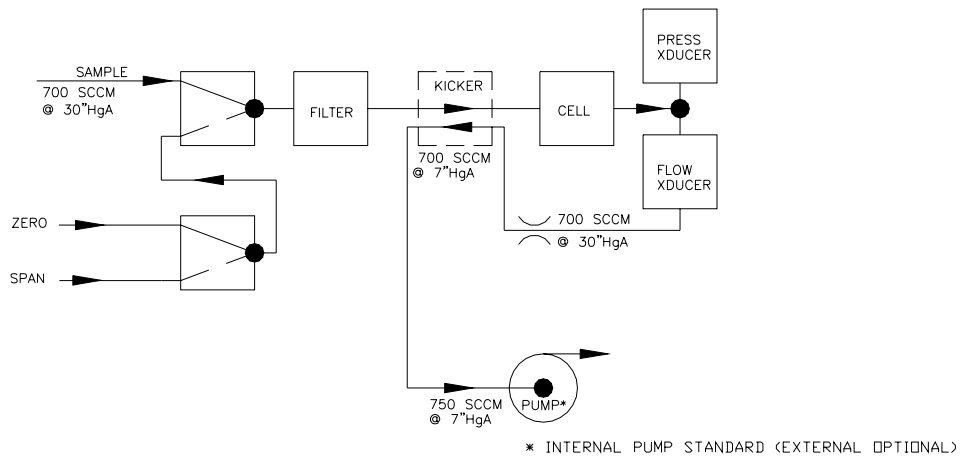

Figure 8-2: Reaction Cell



M100A



M100A with ZERO/SPAN valves

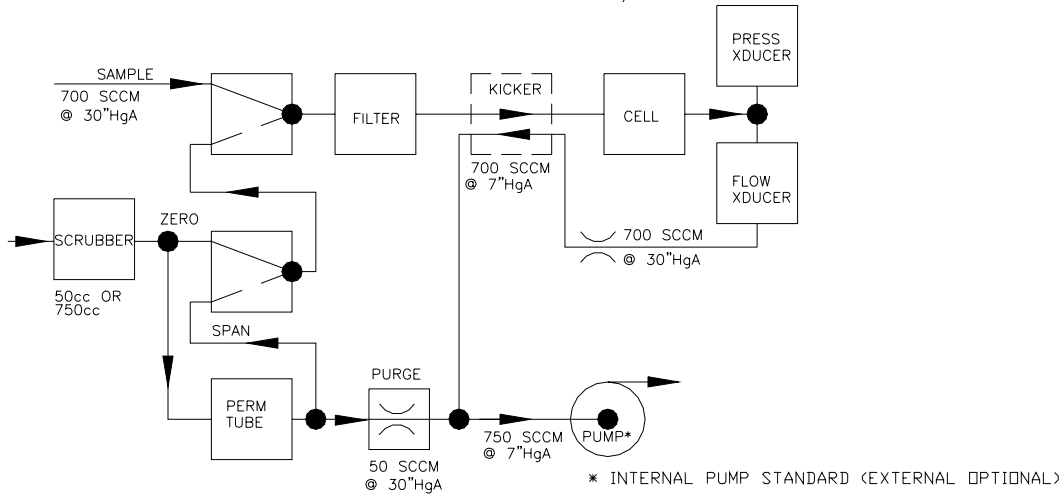

M100A with IZS

**Figure 8-3: Pneumatic Diagram**

## 8.8 Leak Check Procedure

There are two methods of leak checking. First one is the vacuum method which is simplest but it does not show the location of a leak. This vacuum method described below is the general method when a Leak Checker (refer to Figure 9-10) is not readily available. The second method is using pressure and this method can be used to find the exact location of a leak by using bubble solution.

### NOTE

**Do not use bubble solution during vacuum method as the solution may enter and contaminate the cell.**

Vacuum method:

1. Cap the sample inlet port(plug zero air scrubber inlet also if it is installed).
2. Remove the inlet fitting from the pump.
3. Set the TEST function to SAMP FL. Record the reading.
4. Reinstall the inlet fitting of the pump and check the sample flow reading. It should be close( $\pm 20$  CC/min.) to the previous reading in step 4.

After step 1 of above, pull the vacuum for about 15 in-Hg and close the shut off valve of the leak checker. If the pressure changes more than 1 in-Hg within 5 minutes, there is a leak. It is not possible by the vacuum method to tell where the leak is located. See the pressure method below to locate the leak.

Pressure method:

5. Set up Simple Leak Checker as shown in Figure 9-11 or similar one between the pump and exhaust line that is connected to the pump. (Refer to Figure 8-3 for pneumatic diagram.)
  6. Swap the inlet and outlet of the pump so that the pump pressurizes instead of pulling vacuum.
  7. Adjust needle valve such that the gauge pressure does not exceed 15 PSIG.
  8. Apply bubble solution to all the seals, interfaces and fittings to locate the leak.
  9. Tighten the seal or fitting until the leak stops.
27. Lastly, drop off any accumulated bubble solution and properly reinstall the inlet and outlet fittings of the pump.

10. Verify leak by pressurizing the pneumatic system and close the shut-off valve. If the gauge pressure drops more than 1 PSI within 5 minutes, then repeat steps 7 through 10 until the leak stops.
11. When no more leaks can be found reinstall inlet and outlet fittings of the pump, remove the cap from the sample inlet port and the plug from the zero air scrubber.

## **8.9 Light Leak Check Procedure**

1. Scroll the TEST functions to PMT.
2. Input zero gas.
3. Shine a powerful flashlight or portable incandescent light at the inlet and outlet fitting, and at all the joints of the reaction cell. The PMT value should not respond to the light.

If there is a response, tighten the joints or replace the tubing with new black PTFE tubing.

## **8.10 EPROM Replacement Procedure**

1. Turn the instrument power off.
  2. Remove the hold down screw that holds in the V/F-CPU assembly to the motherboard. Disconnect the J9 power connector from the motherboard. Gently lift the assembly far enough out of the instrument to remove the connector from the display and the RS-232 connector.
  3. The CPU board is attached to the larger V/F board.
  4. Remove the board, laying it down on an insulating surface such that the board edge pins on the PCB are on the left. The EPROM chip should be at the top center. The current chip should be labeled with something like "API SO<sub>2</sub> H.1 - - -". See Figure 9-1 for location of prom on CPU card. Gently pry the chip from its socket and replace it carefully with the new chip. Install the chip in the left end of the socket with the notch facing to the right. Make sure that all of the legs insert into the socket correctly.
  5. Re-attach the CPU board to the V/F board, and re-attach the assembly to the motherboard.
  6. Turn the M100A ON and observe the front panel display. As the machine goes through the setup the version number will be displayed on the front panel. It should read the same as the version number printed on the prom.
  7. All setup variables are stored in the E<sup>2</sup>PROM and should not be affected while changing EPROM. Check all settings to make sure that expected setup parameters are present.
28. Re-calibrate the machine so that the default slope and offset are entered.

## 9 DIAGNOSTIC, TROUBLESHOOTING



### NOTE

**The operations outlined in this chapter are to be performed by qualified maintenance personnel only.**

This section of the manual contains information on diagnosing and corrective action procedure for the instrument performance problems. It contains information on how to use and interpret TEST and DIAGNOSTIC data as well as WARNING messages the instrument generates. There is information on how to troubleshoot the instrument subsystems. Finally there is information to perform adjustments such as DAC calibration procedures.

This manual provides troubleshooting procedures that address problems to the board level. For component level troubleshooting, consult the schematics for the appropriate board in Appendix A.1.

### NOTE

**The values of the readings shown on the front panel of the instrument may at times read XXXXXX. This means that the reading is off scale and therefore meaningless.**

### General Troubleshooting Hints

1. Is the fault light on? If it stays on after you clear the warning messages, see Section 9.1.2.
2. Think of the analyzer as three sections to isolate the cause of the problems:

Section 1 - Pneumatics - Over 50% of all analyzer problems are traced to leaks in the pump, sample filter, instrument internal pneumatics, calibrator or external sample handling equipment.

Section 2 - Electronics - data processing section. This can be readily checked out using Electric Test in Section 9.1.3.2.

Section 3- Optics - Optical section consisting of PMT, HVPS, Preamp, and signal processing. Refer to Section 9.1.3.3 on use of Optical Test.

29. Check the TEST functions:

- A. Compare the TEST functions to the factory values in Table 2-1. This will often provide important clues as to the problem.
- B. Check for the sign of the drift, particularly the slope and offset readings:  
The slopes are the software equivalent of the span pot on an analog instrument. If the slopes are not  $1.0 \pm 0.3$ , the gain has changed, usually from:
  - 1) Possible causes for the drift or change of slope are;
    - a) PMT HVPS change
    - b) Incorrect span gas concentration
    - c) Pneumatic leak such as sample filter, pneumatic lines, kicker, reaction cell, etc.
    - d) UV lamp not calibrated
  - 2) Possible causes for the drift or change of offset are;
    - a) Pneumatic leak
    - b) Light leak
    - c) UV filter damaged
    - d) Incorrect zero gas

30. Incorrect span gas concentration - this could come either from the calibrator or entering the expected span gas concentration in the M100A incorrectly, see Table 7-3.

- 4. If the instrument does not respond to span gas check Section 9.2.3.

The above should get you started in diagnosing and troubleshooting the most common faults. If these reasons have been eliminated, the next thing to do is a Factory Calibration covered in Section 9.1.6 or check Section 9.2 for other fault diagnosis. If difficulties persist contact our service department. The 800 telephone number is on the cover page of this manual.

## 9.1 Operation Verification - M100A Diagnostic Techniques

### 9.1.1 Fault Diagnosis with TEST Variables

The Table 9-1 indicates possible fault conditions that could cause the TEST functions to be outside the acceptable range.

**Table 9-1: Test Functions**

Test Function	Factory Set-Up	Comment
RANGE	500 PPB	<p>This is the Range of the instrument. In standard configuration all 2 outputs have the same range.</p> <p>Dual range option allows different ranges for each output. When enabled, there will be 2 range values displayed (range 1 and range 2).</p> <p>Auto range option allows 2 different ranges for each channel, and will automatically switch to the other range dynamically as concentration values require. The TEST values will show the range the instrument is currently operating in, and will dynamically display the alternate range as the range changes occur.</p>
STABIL		<p>The instrument stability is computed for 25 samples with 10 seconds default interval time. The stability value should be compared to the value observed in the factory check-out.</p> <p>Faults that cause high stability values are:</p> <ul style="list-style-type: none"> <li>Pneumatic leak</li> <li>Low (below 600mV) or very unstable UV lamp output</li> <li>Light leak</li> <li>Faulty HVPS</li> <li>Defective Preamp board (02107)</li> <li>Aging detectors</li> <li>PMT recently exposed to room light</li> <li>Dirty/contaminated reaction cell</li> </ul>

*(table continued)*

**Table 9-1: Test Functions (Continued)**

Test Function	Factory Set-Up	Comment
PRES	Check value in Final Test Values Table 2-1	<p>Reaction cell pressure is measured to monitor sample pressure and to compensate any sample pressure variation. Reaction cell pressure is typically 2 Hg-In lower than the ambient pressure due to the internal pressure drop.</p> <p>Faults are caused due to:</p> <ul style="list-style-type: none"> <li>Pneumatic leak</li> <li>Faulty pressure sensor</li> <li>Sample line flow restriction</li> </ul> <p>see Section 9.3.6 Pres/Flow Sensor.</p>
SAMP FL	650 cc/min ±65	<p>This is the instrument flow. It is measured by the solid state flow meter. Incorrect flow can be caused by the plugged orifice, pneumatic leak, or the flow meter itself.</p> <ul style="list-style-type: none"> <li>- A rapid method of determining if the orifice is plugged is to disconnect the sample tube from the reaction cell, then briefly put your finger over the fittings on the cell. You should feel the vacuum build up.</li> <li>- Another reliable method is to attach a rotameter or soap bubble flowmeter to the fittings to measure the flows.</li> </ul> <p>Flow rate will change ± a few cc/min due to changes in ambient air pressure such as cycling of air conditioning, or passing weather fronts. Changing altitude changes the ambient air pressure and therefore the sample flowrate. Flow variation have a negligible effect on the analyzer reading. See Section 9.2.2 Flow Check.</p>

*(table continued)*

Table 9-1: Test Functions (Continued)

Test Function	Factory Set-Up	Comment
PMT	0 - 5000 mV	<p>This is the instantaneous output of the PMT.</p> <p>The PMT voltage values will be relatively constant when:</p> <p>Electric test - variation in the 2000 mV signal observed will be noise of the V/F board and preamp noise. See Section 9.1.3.2.</p> <p>Optic test - variation in the 2000 mV signal will be PMT dark current, preamp, HVPS plus item 1 above. See Section 9.1.3.3.</p> <p>Sampling zero gas.</p> <p>Sampling stable SO<sub>2</sub> span gas.</p> <p>When sampling zero gas the PMT reading should be less than 450mV and relatively constant.</p> <p>High or noisy readings could be due to:</p> <p>Pneumatic leak.</p> <p>Excessive background light which is caused by a possible aging UV filter.</p> <p>Low UV lamp output.</p> <p>PMT recently exposed to room light. It takes 24-48 hours for the PMT to adapt to dim light.</p> <p>Light leak in reaction cell.</p> <p>Reaction cell contaminated.</p>
UV LAMP	1000 - 4800 mV	<p>This is the instantaneous reading of the UV lamp intensity. Typical UV lamp intensity is between 2000 mV and 4000 mV. See Section 9.4.2 for how to peak the UV lamp output. Intensity lower than 1000 mV will cause WARNING and below 600mV will cause to display XXXXX.X.</p> <p>Low UV lamp intensity could be due to:</p> <p>Aging UV lamp.</p> <p>UV lamp position out of alignment.</p> <p>Faulty lamp transformer.</p> <p>Aging or faulty UV detector.</p> <p>Dirty optical components.</p>

(table continued)

**Table 9-1: Test Functions (Continued)**

Test Function	Factory Set-Up	Comment
STR LGT	0 - 100 ppb	<p>Stray light is the background light of the reaction cell expressed in ppb while sampling zero gas. High stray light could be caused by :</p> <p>Aging UV filter.</p> <p>Contaminated reaction cell.</p> <p>Light leak.</p> <p>Pneumatic leak.</p>
DRK PMT	-50 - +200 mV	<p>This is the reading of the PMT signal without the UV lamp. When the shutter is energized, it blocks the UV light causing complete darkness inside of the reaction cell. This darkness reading by the PMT is monitored and compensated for any PMT dark current drift.</p> <p>High dark PMT reading could be due to:</p> <p>Light leak.</p> <p>Shutter not closing completely.</p> <p>High PMT temperature.</p> <p>High electronic offset.</p>
DRK LMP	-50 - +200 mV	<p>This is the reading of the UV reference detector without the UV lamp. When the shutter blocks the UV light, UV detector signal is the dark current of the detector itself. This dark current is monitored and compensated for any UV detector dark current drift.</p> <p>High dark UV detector could be caused by:</p> <p>Light leak.</p> <p>Shutter not closing completely.</p> <p>High electronic offset.</p>

*(table continued)*

**Table 9-1: Test Functions (Continued)**

Test Function	Factory Set-Up	Comment
SLOPE	1.0 ± 0.3	<p>The slope can be thought as a gain term which determines the steepness of the calibration curve.</p> <p>M100A will operate normally even the slope is out of range, however it is preferred within the range for optimum operation of the analyzer.</p> <p>Slope out of range could be due to:</p> <p>Analog gain pot needs adjustment (see Section 9.1.6).</p> <p>Poor calibration quality (see Section 7.10).</p> <p>UV lamp not calibrated (see Section 9.1.6)</p>
OFFSET	<250 mV	<p>This is essentially identical to the stray light except it is expressed in mV.</p> <p>High offset could be due to:</p> <p>Light leak.</p> <p>Aging UV filter.</p> <p>Contaminated reaction cell.</p> <p>Pneumatic leak.</p> <p>Poor calibration quality.</p>
HVPS	550 - 900 V	<p>This represents the scaled-up HVPS programming voltage to the HVPS. The design of the HVPS precludes taking a single reading that indicates the health of the supply. Refer to the HVPS Troubleshooting Section 9.3.10 for a procedure for testing the HVPS. This TEST function is used primarily to set the HVPS voltage value and the reading should be very stable and constant. A value not in the 400 to 900 volt range indicates problems with the HVPS supply.</p>
DCPS	2500 ± 200 mV	<p>DCPS is a composite of the +5 and ± 15VDC supplies. It has been arbitrary set at 2500 ± 200mV. If it is not in this range one of the voltages in the supply is not working. Check the procedures for diagnosing the Power Supply Module.</p>

*(table continued)*

Table 9-1: Test Functions (Continued)

Test Function	Factory Set-Up	Comment
RCELL TEMP	50 ± 1°C	The reaction cell temperature is controlled to 50°C ± 1°C by the computer. It should only read other values when the instrument is warming up. If the value is outside the acceptable range, go to the procedure for diagnosing the Reaction cell temp supply. The alarm limits are less than 45°C and greater than 55°C.
BOX TEMP	8 - 48°C	The Box Temp is read from a thermistor on the Status/Temp board (01086). It should usually read about 5C above room temp. The M100A is designed to operate from 5 to 40°C ambient. Therefore the box temperature should be in the range of about 10 to 50°C. Temperatures outside this range will cause premature failures of components, and poor data quality. Warning limits are < 8°C and > 52°C.
PMT TEMP	7 ± 1°C	The PMT detector is very temperature sensitive. The PMT temperature should always be 7°C, except at power-up. Temperatures more than ±1°C from the set point indicate problems with the cooler circuit. See Section 9.3.9 for PMT cooler diagnostic and troubleshooting. Warning limits are < 0°C and > 15°C.
IZS TEMP	50 ± 0.3°C	The IZS temperature is the temperature of the permeation tube oven. This temperature is controlled by the CPU and is adjustable in 0.1°C increments. This adjustment allows small changes in permeation tube temperature so the permeation rate can be adjusted to the desired value. The control loop variations show a temperature swing at the control thermistor of a few tenths of a degree. Temperature fluctuations of the perm tube however are less than .1°C. Warning limits are < 45°C and > 55°C.
TIME		This is the time of day clock readout. It is used to time the AutoCal cycles. The speed of the clock can be adjusted by the CLOCK_ADJ variable in the VARS menu. The clock can be set via SETUP-CLOCK-TIME from the front panel.

## 9.1.2 Fault Diagnosis with WARNING Messages

The M100A monitors several internal values for alarm conditions. If the condition for an alarm is met, the alarm is displayed on the front panel and the warning is transmitted out the RS-232 port. Any time the instrument is powered up the SYSTEM RESET alarm will be displayed. Generally, it is ok to ignore warnings that are displayed shortly after power-up; only if they persist should they be investigated.

Table 9-2 shows the warning messages and gives some possible causes.

**Table 9-2: Front Panel Warning Messages**

Message	Description
SYSTEM RESET	Analyzer was reset/powerd on. This warning occurs every time the instrument is powered up, as in a power failure. It can also occur if the RAM or EEPROM is reset.
RAM INITIALIZED	RAM was erased. The RAM contains the DAS averages which get erased when the RAM is initialized. It also contains temporary data used by the M200A to calculate concentrations. No setup variables are stored in the RAM.
UV LAMP WARNING	UV lamp output is below 1000mV or above 4995mV or PMT output above 4995 mV. UV lamp could be aging or need to peak output by adjusting the position. Also dirty optical system will cause to read lower.
SHUTTER WARNING	Shutter system is not functioning properly. Either it is not energized electrically or has mechanical problem. Strong light leak could cause false shutter alarm. UV or PMT dark offset is above 200mV (default value)
HVPS WARNING	HVPS control voltage is above 900 V or below 400 V. Preamp circuit could be out of adjustment or PMT sensitivity is too weak.
SAMPLE FLOW WARNING	The measured sample flow is outside the hi/low limits. Leak in pneumatic system is the main cause of the warning although flow sensor itself could be the cause.
SAMPLE PRESS WARNING	Sample pressure below 15”Hg or above 35”Hg.
BOX TEMP WARNING	Box temp. out of spec. Instrument fan failure, enclosure temperature failure. Operation of the M100A in a too warm or cold environment will cause degradation of data quality and shorten the life of the instrument.
RCELL TEMP WARNING	Reaction cell temp. out of spec. The warning message is most often present during initial warm-up or poor electrical contact.

*(table continued)*

**Table 9-2: Front Panel Warning Messages (Continued)**

Message	Description
IZS TEMP WARNING	IZS temp. out of spec. The warning message is most often present during initial warm-up or poor electrical contact.
PMT TEMP WARNING	PMT temp. out of spec. The PMT temp has its own control circuit on the preamp (01141) board. Warnings will occur during initial warm up period. The warning can occur if the 7 pin connector to the interior of the sensor is not plugged in. The power from the PSM should be checked for proper voltage (+15VDC ± 0.5) on the TEC driver circuit mounted on the fan duct. Test point 1 and test point 4 (white) should measure 15 VDC and LED should lit brightly.
CANNOT DYN ZERO	Dynamic zero cal. out of spec. The reading of the PMT was too high for the ZERO button to appear. Make sure the instrument is receiving zero gas. Check for dirty reaction cell. Do the factory calibration procedure located in Section 9.1.6.
CANNOT DYN SPAN	Dynamic span cal. out of spec. The reading of the PMT was too high or low for the SPAN button to appear. Make sure the instrument is receiving correct concentration span gas. Make sure the expected span concentration is entered. Check for dirty reaction cell. Do the factory calibration procedure located in Section 9.1.6.
V/F NOT INSTALLED	V/F (00514) board has failed. The V/F board did not respond to commands from the CPU. This probably means 1. board not seated in socket 2. defective board 3. defective back plane connector
DCPS WARNING	DC power supply output is put of specification. Test measurement display is below 2300mV or above 2700mV. Refer to Section 9.3.5.

### 9.1.3 Fault Diagnosis using DIAGNOSTIC Mode

Diagnostic mode can be looked at as a tool kit of diagnostics to help troubleshoot the instrument.

To enter DIAG mode press:

SETUP-MORE-DIAG

The diagnostic modes are summarized in Table 9-3. To access these functions, after you have pressed SETUP-MORE-DIAG, then press NEXT, PREV to select the desired mode then press ENTR to select that mode. Table 9-3 below contains a summary of the diagnostic modes and their operation. This section is a detailed description of the test and suggestions for its use.

**Table 9-3: Summary of Diagnostic Modes**

DIAG Mode	Description
SIGNAL I/O	Gives access to the digital and analog inputs and outputs on the V/F board. The status or value of all of the signals can be seen. Some of the signals can be controlled from the keyboard. Table 9-4 gives details on each signal and information on control capabilities. NOTE - some signals can be toggled into states that indicate warnings or other faults. These settings will remain in effect until DIAG mode is exited, then the M100A will resume control over the signals.
ANALOG OUTPUT	Causes a test signal to be written to the analog output DAC's. The signal consists of a scrolling 0%, 20%, 40%, 60%, 80%, 100% of the analog output value. The scrolling may be stopped by pressing the key underneath the % display to hold that value. The exact voltage values depend on the jumper settings on the analog output buffer amplifiers.
DAC CALIBRATION	The analog output is created by 4 digital-to-analog converters. This selection starts a procedure to calibrate these outputs. Refer to Section 9.3.3.1 for a detailed procedure.
OPTICAL TEST	Sets the M100A into a known state and turns on an LED near the PMT to test the instrument signal path. See Section 9.1.3.3 for details on using this test.
ELECTRICAL TEST	Tests just the electronic portion of the PMT signal path. Used in conjunction with optic test, see Section 9.1.3.2.
LAMP CAIBRATION	This feature allows to update the Lamp Calibration value. Displayed value is the current lamp intensity and pressing ENTR key will update the Lamp Calibration value. Refer to Section 9.4.2 for UV Lamp adjustment. See also Section 9.1.6 Factory Calibration Procedure.
TEST CHANNEL OUTPUT	This feature allows to output scaled voltage of most test measurement through the analog output terminal. Refer to Section 9.1.5.
RS-232	Causes a 1 second burst of data to be transmitted from the RS-232 port. Used to diagnose RS-232 port problems. See Section 9.1.3.6, 9.3.2 for RS-232 port diagnostic techniques.

## 9.1.3.1 Signal I/O Diagnostic

Table 9-4: Diagnostic Mode - Signal I/O

No	Signal	Control	Description
0	DSP_BROWNOUT	NO	Display brownout is used to keep the display from getting corrupted during low line voltage conditions. Circuitry on the Status/Temp board (01086) senses low line voltage and sets this bit. The CPU reads this and generates the BROWNOUT_RST signal described below.
1	EXT_ZERO_CAL	NO	Shows state of status input bit to cause the M100A to enter Zero Calibration mode. Use to check external contact closure circuitry.
2	EXT_SPAN_CAL	NO	Shows state of status input bit to cause the M100A to enter the Span Calibration mode. Use to check external contact closure circuitry.
3	SPAN_VALVE	YES	Switches the IZS Zero/Span valve. Use this bit to test the valve function.
4	CAL_VALVE	YES	Switches the IZS Sample/Cal valve. Use this bit to test the valve function.
5	DARK_SHUTTER	YES	Energizes the shutter. Use this bit to test the shutter function which will block mechanically the UV lamp light source.
6	RCELL_HEATER	NO	Shows the status of the reaction cell heater. This has the same function as the LED in the power supply module.
7	IZS_HEATER	NO	Shows the status of the IZS permeation tube heater. This has the same function as the LED in the power supply module.
8	ELEC_TEST	YES	Turns on electric test bit in preamp. Should be used for troubleshooting preamp circuit. We recommend you use the ELEC TEST button in the DIAG menu to operate electric test.
9	OPTIC_TEST	YES	Turns on optic test bit in preamp. Should be used for isolating PMT detector system from the rest of the preamp circuit. We recommend you use the OPTIC TEST button in the DIAG menu to operate optic test.

*(table continued)*

**Table 9-4: Diagnostic Mode - Signal I/O (Continued)**

No	Signal	Control	Description
10	BROWNOUT_RESET	YES	Brownout reset works in conjunction with DSP_BROWNOUT. When DSP_BROWNOUT is set the CPU sends a signal to reset the display and clear the DSP_BROWNOUT.
11	ST_LAMP_ALARM	YES	Status Bit - UV Lamp alarm Logic High = UV lamp output too low Logic Low = Lamp output normal
12	ST_HIGH_RANGE	YES	Status Bit - Autorange High Range Logic High = M100A in high range of autorange mode Logic Low = M100A in low range of autorange mode
13	ST_SHUT_ALARM	YES	Status Bit - Shutter alarm Logic High = Shutter not working Logic Low = Shutter working properly
14	PRMP_RNG_HI	YES	Switches the preamp (01105) hardware range. Standard ranges are 2000 and 20,000 ppb. Logic high = 20,000 ppb; logic low = 2000 ppb. M100A will reset range to correct value based on user set range value.
15	ST_ZERO_CAL	YES	Status Bit - Zero Calibration mode Logic high = M100A in Zero cal mode Logic low = Not in Zero cal mode
16	ST_SPAN_CAL	YES	Status Bit - Span Calibration mode Logic high = M100A in Span cal mode Logic low = Not in Span cal mode
17	ST_FLOW_ALARM	YES	Status Bit - Flow alarm Logic High = Sample flow out of spec Logic Low = Flows within spec
18	ST_TEMP_ALARM	YES	Status Bit - Temperature alarm Logic High = Reaction cell, IZS, PMT, Box temps out of spec Logic Low = Temps within spec

*(table continued)*

**Table 9-4: Diagnostic Mode - Signal I/O (Continued)**

No	Signal	Control	Description
19	ST_DIAG_MODE	YES	Status Bit - In Diagnostic mode Logic High = M100A in Diagnostic mode Logic Low = Not in Diagnostic mode
20	ST_POWER_OK	YES	Status Bit - Power OK Logic High = Instrument power is on Logic Low = Instrument power is off
21	ST_SYSTEM_OK	YES	Status Bit - System OK Logic High = No instrument warning present Logic Low = 1 or more alarm present
22	ST_HVPS_ALARM	YES	Status Bit - HVPS alarm Logic High = HVPS out of spec Logic Low = HVPS within spec
23	PMT_SIGNAL	NO	Current PMT voltage. Same as PMT voltage in TEST menu. Bi-polar, typically in 0-5000mV range. A constant value of 5000mV indicates offscale.
24	RCELL_TEMP	NO	Reaction Cell temperature. 3500 mV for 50°C.
25	BOX_TEMP	NO	Box Temperature. Typically 1800 mV for 25°C.
26	IZS_TEMP	NO	IZS permeation tube oven temp. Typically 3500 mV for 50°C.
27	PMT_TEMP	NO	PMT cold block temperature. Typically 4300 mV for 7°C.
28	DCPS_VOLTAG	NO	DC power supply composite voltage output. Typically 2500 mV.
29	SAMPLE_PRES	NO	Sample pressure in mV. Typical sea level value = 4300mV for 29.9" HG-A.
30	SAMPLE_FLOW	NO	Sample flow in mV. Typical value is about 3200 mV for 650cc/min.
31	HVPS_VOLTAG	NO	HVPS programming voltage. Output of HVPS is 1000x value present.
32	DAC_CHAN_0	NO	Output of SO <sub>2</sub> (DAC0/RANGE1) in mV.
33	DAC_CHAN_1	NO	Output of SO <sub>2</sub> (DAC1/RANGE2) in mV.

*(table continued)*

**Table 9-4: Diagnostic Mode - Signal I/O (Continued)**

No	Signal	Control	Description
34	DAC_CHAN_2	NO	Output of spare (DAC2) channel in mV.
35	DAC_CHAN_3	NO	Test Channel (DAC3) output.
36	UVLAMP_SIGNAL	NO	Current UV lamp signal voltage in mV. Same as UV LAMP in TEST menu. Bi-polar, typically 0-5000 mV range. A constant value of 5000 mV indicates offscale.
37	CONC_OUT_1	YES	DAC0 (SO <sub>2</sub> /RANGE1) analog output in mV
38	CONC_OUT_2	YES	DAC1 (SO <sub>2</sub> /RANGE2) analog output in mV
39	TEST_OUTPUT	YES	DAC3 (TEST CHANNEL) analog output in mV

### 9.1.3.2 Electric Test

This function injects a constant voltage between the preamplifier and the buffer amplifier on the preamp board. Electric test checks part of the preamp, the V/F and computer for proper functioning. The result of electric test should be a smooth quiet signal as shown by constant values for the SO<sub>2</sub> concentration. Likewise the analog outputs should produce a smooth quiet trace on a strip chart (analog output range is set to 2000ppb and auto-ranging is disabled).

Procedure:

1. Scroll the TEST function to PMT.
2. Press SETUP-MORE-DIAG, scroll to ELECT TEST by pressing the NEXT button. When ET appears, press ENTR to turn it on.
3. The value in PMT should come up to 2000 mV ± 1000mV in less than 15 sec.

If the HVPS or the span gain adjust on the preamp card has been changed without doing a FACTORY CALIBRATE the reading in step 3 may be different than 2000 mV, since the overall calibration affects ELECTRIC TEST. See Section 9.1.6 for factory calibration procedure.

4. To turn off ET press EXIT

If ET is a steady 2000 ± 1000 mV, that means the Power Supply Module, preamp buffer amplifier, V/F, CPU, and display are all working properly.

**NOTE**

**If the SO<sub>2</sub> concentration display is not within the nominal range of 1000 ± 100 ppb, then the lamp ratio may need to be updated. See Section 9.1.6, step 2 of PMT Calibration procedure.**

### 9.1.3.3 Optic Test

Optic test turns on a small LED inside the PMT housing which simulates the signal from the reaction cell. OT tests the entire signal detection subsystem. By observing the level, noise and drift of this test, correct operation of many sections of the analyzer can be verified.

The implementation of OT involves several changes to the instrument operating conditions. The M100A does the following when switching to optic test:

1. Save the current instrument setup as to autorange, dual range, current range. D/A analog output is set at 2000 ppb range and auto-ranging is disabled.
2. Allow to sample zero gas.
3. Select SETUP-MORE-DIAG, scroll to select the optic test and push ENTR button.
4. The PMT reading in TEST functions should be 2000 ± 1000mV.

If the HVPS or the span gain adjust on the preamp card has been changed without doing a FACTORY CALIBRATE the reading in step 4 may be different than 2000 mV, since the overall calibration affects OPTIC TEST. Also if the SO<sub>2</sub> concentration display is not within the nominal range of 1000 ± 500 ppb, then the lamp ratio may need to be updated. See Section 9.1.6 for factory calibration procedure.

### 9.1.3.4 Analog Out Step Test

The Step Test is used to test the functioning of the 4 DAC outputs on the V/F board. The test consists of stepping each analog output 0-20-40-60-80-100% of the output. If the analog outputs are set for 0-5V full scale the outputs would step 0-1-2-3-4-5VDC. The stepping can be halted at any value by pressing the key under the percentage on the front panel. When the test is halted, square brackets are placed around the percentage value in the display. Pressing the key again resumes the test. This test is useful for testing the accuracy/linearity of the analog outputs.

### 9.1.3.5 DAC Calibration

The Digital to Analog Converters (DAC) are calibrated when the instrument is set up at the factory. Re-calibration is usually not necessary, but is provided here in case the V/F board needs to be replaced and re-calibrated. The procedure for using the DAC Calibration routines are in the Troubleshooting Section 9.3.3.1.

### 9.1.3.6 RS-232 Port Test

This test is used to verify the operation of the RS-232 port. When started, it outputs the ASCII letter X for about 2 seconds. During the test it should be possible to detect the presence of the signal with a DVM. A detailed procedure is given in the Troubleshooting Section 9.3.2.

## 9.1.4 M100A Internal Variables

The M100A software contains many adjustable parameters. Many of the parameters are set at time of manufacture and do not need to be adjusted for the lifetime of the instrument. It is possible to change these variables either through the RS-232 port or the front panel. **Altering the values of many of the variables, especially those not listed on Table 9-5, will adversely affect the performance of the instrument and could possibly affect the EPA equivalency designation.** Therefore it is recommended that these variables not be adjusted unless you have a clear understanding of the effects of the change.

Table 9-5 contains a description of "easy variables" which do not require special password from the front panel. "Hard variables" require special password and contact factory if you need to adjust them. "V LIST" of RS-232 will list all the variables except those that should never be manually edited.

To access the VARS menu press SETUP-MORE-VARS-ENTR. Use the PREV-NEXT button to select the variable of interest and press EDIT to examine/change the value, then press ENTR to save the new value. If no change is required, press EXIT.

**Table 9-5: Model 100A Variables**

No.	Name	Units	Default Value	Value Range	Description
0	DAS_HOLD_OFF	MIN	15.0	0.5-20.0	Hold off duration after calibration or diagnostic mode.
1	TPC_ENABLE		ON	ON-OFF	Temp/Pres compensation enable
2	RCELL_SET	°C	50	30-70	Reaction cell temperature set point
3	IZS_SET	°C	50	30-70	IZS temperature set point
4	DYN_ZERO		OFF	OFF/ON	Enable to adjust zero calibration through remote contact closure
5	DYN_SPAN		OFF	OFF/ON	Enable to adjust span calibration through remote contact closure
6	RS232_MODE	Bit Field	8	0-99999	Value is SUM of following decimal numbers: 1= enable quiet mode 2= enable computer mode 3= enable security feature 4= enable front panel RS-232 menus
7	CLOCK_ADJ	Sec.	0	± 60	Real-time clock adjustment

## 9.1.5 Test Channel Analog Output

Many of the TEST functions have an analog voltage associated with them. As a diagnostic aid it is possible to route any one of the various test voltages out the 4th analog output port(see Figure 2-2). Following Table 9-6 lists the test measurements which may be routed to test channel output. To route an analog test measurement to test channel output, press SETUP-MORE-DIAG-ENTR and use the PREV or NEXT buttons to scroll to the TEST CHAN OUTPUT and press ENTR. Press the PREV or NEXT buttons to scroll to the desired measurement and press ENTR.

**Table 9-6: Test Channel Output**

#	Name	Description	Scaled Range
0	NONE		
1	PMT READING	PMT output	0 - 5000mV
2	UV READING	UV lamp output	0 - 5000mV
3	SAMPLE PRESS	Sample pressure sensor	0 - 40 in-Hg
4	SAMPLE FLOW	Sample flow rate	0 - 1000 cc/min.
5	RCELL TEMP	Reaction cell temp. sensor	0 - 70°C
6	BOX TEMP	Box temp. sensor	0 - 70°C
7	IZS TEMP	IZS temp. sensor	0 - 70°C
8	PMT TEMP	PMT temp. sensor	0 - 20°C
9	CONV TEMP	H2S converter temperature(H2S version only)	0 - 500°C
10	DCPS VOLTAGE	DC power supply	0 - 5000mV
11	HVPS VOLTAGE	HV power supply sensor	0 - 1000V
12	DAS AVG	DAS concentration using current D/A range	0 - Full Scale (RANGE 1)

When a measurement other than NONE is selected, an additional test measurement appears on the display, which has the format "TEST=XXXXX.X MV" and shows the mV value currently being output to test analog output port.

There is also a setup variable accessible through the RS-232 which controls which test measurement is selected. This variable is called TEST\_CHN\_ID where ID is from 0-12 as in the table above.

### 9.1.6 Factory Calibration Procedure (Quick Cal)

This procedure is referred to in other Teledyne API instruments as the "Quick Cal" procedure. It is used at the factory when the instrument is first set-up.

The Factory Cal procedure balances the PMT, preamp, and software gain factors so the instrument has optimum noise, linearity, and dynamic range. It should be used when you are unable to zero or span the instrument, when the slope and offset values are outside of acceptable range, or when other more obvious reasons for problems have been eliminated.

PMT Calibration Procedure:

Note: In this procedure a range of 500 ppb and a span gas concentration of 400 ppb is used as an example. Other values can be used.

1. On the Preamp board, set S2 to 'B', set S1 to 2. Turn R19 25 turns counter-clockwise, then 12 turns clockwise. (see Figure 2-5)
2. Adjust the UV lamp per Section 9.4.2 and reset the Lamp Cal value by selecting SETUP-MORE-DIAG and scroll to select LAMP CALIBRATION. Reset the LAMP CAL value by pressing ENTR. Value displayed is the current UV lamp intensity and pressing ENTR will update the value.
3. Set RANGE MODE to SING by SETUP-RNGE-MODE to select single range operation.
4. Set the RANGE to 500 ppb by SETUP-RNGE-SET and key in 500, then press ENTR.
5. Input 400 ppb of SO<sub>2</sub> span gas in the sample inlet port.
6. Scroll to the PMT - TEST function.
7. Calculate the expected PMT mV reading.

For ranges up to 2000 ppb;

$$\text{PMT mV} = (\text{span gas concentration} \times 2) \frac{\text{Sample Pressure}}{29.9} + \text{offset(mV)}$$

For ranges above 2001 up to 20000 ppb;

$$\text{PMT mV} = (\text{span gas concentration} \times 0.2) \frac{\text{Sample Pressure}}{29.9} + \text{offset(mV)}$$

8. Adjust S2, the HVPS coarse adjustment, on the preamp board to the setting that produces a signal that is closest to expected value. Adjust S1, the HVPS fine adjustment, to the setting that produces a signal that is closest to expected value. Use R19 to trim the reading to final fine adjustment.

31. Recalibrate the instrument for both zero and span to calculate the slope and offset. (Refer to Section 7). Above procedure is to assure that the instrument will operate with optimum noise, linearity, and dynamic range.

**9.1.6.1 Electric Test (ET) Procedure:**

1. Any time the gain of the PMT buffer amplifier circuit (R19) is changed (refer component location label inside of the Preamp cover), that will change the ET reading. Since the gain was adjusted in the above procedure, do the following to re-adjust the ET signal.
2. To re-adjust ET press SETUP-MORE-DIAG, then scroll to ELEC TEST and press ENTR.
3. Scroll the TEST functions until PMT is displayed.
4. Adjust R27 until  $2000\text{mV} \pm 1000$  is displayed.
5. Press EXIT to return to SAMPLE mode.

**9.1.6.2 Optic Test (OT) Procedure:**

1. Any time the PMT buffer amplifier circuit (R19) gain and/or the PMT high voltage setting is changed, the OT reading will also change. The PMT cal procedure changed both of these values.
2. To re-adjust OT press SETUP-MORE-DIAG, then scroll to OPTIC TEST and press ENTR.
3. Scroll the TEST functions until PMT is displayed.
4. Adjust R25 until  $2000\text{mV} \pm 1000$  is displayed.
5. Press EXIT to return to SAMPLE mode.

## 9.2 Performance Problems

When the response from a span check is outside the control limits, the cause for the drift should be determined, and corrective action should be taken. Some of the causes for drift are listed below:

**NOTE**

**Before starting troubleshooting, it has been our experience that about 50% of all analyzer performance problems are sooner or later traced to leaks.**

1. Fluctuations in flow. Such as leaks or plugged orifices.
32. Lack of preventive maintenance.
33. Change in zero air source.
  - A. Air containing SO<sub>2</sub> leaking into zero air line.
  - B. Saturation of charcoal scrubber.
  - C. Cracked DFU filter.
4. Change in span gas concentration.
  - A. Zero air or ambient air leaking into span gas line.
  - B. Permeation tube or cal gas tank exhaustion.
  - C. Dirty particulate filter.

### 9.2.1 AC Power Check

1. Check that power is present at main line power input. Verify that correct voltage and frequency is present.
2. Check that the unit is plugged into a good socket. Analyzer must have 3-wire safety power input.
3. Check circuit breaker. Circuit breaker is part of the front panel power switch. It is set each time the instrument power is turned on. If there is an internal short causing a trip, the switch will automatically return to the OFF position when an attempt is made to turn it on.

## 9.2.2 Flow Check

1. Check TEST function SAMP FLOW - Should be  $650 \pm 65$ cc/min.
2. Check that pump is running. Observe pump for proper operation.
3. Test that pump is producing vacuum by removing fitting at the inlet of the pump and checking for suction at fitting.
4. Check for flow at the reaction cell.
  - A. Remove the 1/8" fitting from the reaction cell and plug the fitting on the reaction cell with your finger and note the weak vacuum produced.
  - B. Using independent flow meter verify the flow rate into the reaction cell. It should be about same as the TEST function SAMP FLOW reading. If not within the range, then flow sensor is out of adjustment or broken (see Section 9.3.6).
5. Check instrument inlet flow using separate flow meter and compare the flow rate to the SAMP FLOW reading. If the flow is lower than expected flow, then leak check the analyzer as described in Section 8.8.
6. If there is no leak and all above procedures can not correct flow rate reading, then replace the flow meter (see Figure 9-6).

## 9.2.3 No Response to Sample Gas

34. Confirm general operation of analyzer.
  - A. Check for AC Power, Section 9.2.1.
  - B. Do flow checks, Section 9.2.2.
  - C. Confirm that sample gas contains SO<sub>2</sub>.
35. Check instrument electronics.
  - A. Do ELEC TEST procedure in DIAGNOSTIC menu Section 9.1.3.2.
  - B. Do OPTIC TEST procedure in the DIAGNOSTIC menu Section 9.1.3.3.
  - C. Check if UV LAMP reading of TEST function is greater than 350mV.

If the M100A passes ET and OT that means the instrument is capable of detecting light and processing the signal to produce a reading. Therefore, the problem is most likely in the pneumatics.

## 9.2.4 Negative Concentration Display

1. Mis-calibration. The 'zero' gas that was used to zero the M100A contained some SO<sub>2</sub> gas - that is it had more SO<sub>2</sub> gas than that of the sample air. May also be caused by doing a zero calibration using ambient air.
2. Broken PMT temperature control circuit, causing high zero offset. Check PMT temperature which should be  $7 \pm 1^{\circ}\text{C}$ .
3. Aging UV filter causing high stray light. Check STR. LGT reading of TEST function. It should be less than 100 ppb.
4. Check for light leak.
5. Check for used up zero air canister if the instrument has the IZS option and the canister is being used to zero the instrument.
6. New kicker or new reaction cell may take a week or longer of conditioning time to reach low steady state condition.

## 9.2.5 Excessive Noise

Common reasons for excessive noise are:

1. Leak in pneumatic system.
  2. Light leak - check the sensor module with strong light.
  3. HVPS noisy - see HVPS test procedure. See Section 9.3.10.
  4. Defective electronic components on preamp board. - use optic test and electric test to check electronics, optics and observe noise.
  5. Contamination of reaction cell and optical system - This can be wet air or impurities. This can be detected by high PMT readings with zero air as sample gas. Clean reaction cell as described in Section 8.6.
36. Broken PMT temperature control circuit. Check PMT TEMP - TEST function.
6. Mis-calibration. Check SLOPES in TEST function.
  7. Too low UV lamp output. Should be higher than 600mV. Replace the lamp if it is lower than this value.
  8. High stray lights - UV filter is aging.

## 9.2.6 Unstable Span

Common causes are:

1. Leak in pneumatic system.
2. Unstable UV lamp output - replace lamp.
3. Sample lines or sample filter dirty - clean or replace.
4. Plugged sample inlet orifice - clean with methanol and sonic cleaner.
5. Defective HVPS - use optic test and electric test to isolate the HVPS. See also Section 9.3.10 HVPS test procedure.
6. Bad or defective PMT detector - check Optic test.
7. Reaction cell temperature not stable - observe warning messages, or RCELL TEMP in TEST functions. Check diagnostic LED in Power Supply Module for normal cycling.
8. PMT temperature not stable - observe warning messages, or PMT TEMP in TEST functions.
9. Sample vent line too short, allowing room air to mix with span gas - line should be a minimum of 15" long.
10. Calibration gas source unstable - if equipped with IZS option, permeation tube could be nearing exhaustion or IZS oven temperature is unstable, check warning messages, or observe IZS TEMP in TEST function.
11. IZS permeation tube unstable.
  - A. IZS subsystem leaking - leak check
  - B. IZS zero air scrubber exhausted - replace charcoal
  - C. IZS oven temperature unstable - verify stable temperature
  - D. Permeation tube installed upside down or wrong side, see Figure 6-1 for correct installation.

## 9.2.7 Unstable Zero

Common causes are:

1. Leak in pneumatic system.
2. Light leak - check the sensor module with strong light.
3. If equipped with IZS, zero air scrubber exhausted - replace charcoal and check broken DFU filter.
4. Sample lines or sample filter dirty - clean or replace.
5. Zero gas source unstable - verify quality of zero air and the flow rate.

## 9.2.8 Inability to Span

**If the SPAN button is not illuminated when attempting to span, that means the reading is outside of the software gain ranges allowed.** In an analog instrument it would be the equivalent to the span pot hitting the maximum.

Here are some things to check:

1. Check the expected span concentration value in CAL-CONC, and compare this to the value of the calibrator span gas being input. They should be close.
2. Check the PMT - TEST function. The value there should be about 2 x the expected span concentration in step 1 above for range settings up to 2000 ppb in addition of the offset value. If over 2000 ppb, the value should be about 0.2 x the expected span concentration in addition of the offset value.
3. Check ET (see Section 9.1.3.2) and OT (see Section 9.1.3.3) for a response to 2000 mV on the PMT - TEST function.
4. If the above do not check out, perform the Factory Calibration Procedure Section 9.1.6.

## 9.2.9 Inability to Zero

If the ZERO button is not illuminated when attempting to zero, that means the reading is outside of the software gain ranges allowed. In an analog instrument it would be the equivalent to the zero pot hitting the maximum.

Here are some things to check:

37. Select the PMT - TEST function. With zero gas going into the instrument, the value should be less than 250 mV, typically 80 - 160 mV. If you are getting a high reading, the probable reasons are:
  - A. Leak that admits gas containing SO<sub>2</sub>.
  - B. Contaminated reaction cell. Remove and clean cell.
  - C. Light leak.
  - D. Zero gas that isn't really zero. Make sure you're not trying to zero the machine with ambient air or span gas.
  - E. Bad UV filter.

## 9.2.10 Non-Linear Response

Common causes are:

1. Leak in pneumatic system.
2. Calibration device in error - re-check flowrate and concentrations, especially at low concentrations.
3. Contamination in sample delivery system:
  - A. Dirt in sample lines or reaction cell.
  - B. Dilution air contains sample or span gas.
  - C. Dirty particulate filter.
4. Sample inlet vent line too short - should be at least 15".
5. Back pressure on sample inlet.

### 9.2.11 Slow Response

38. Contaminated or dirty sample delivery pneumatics

- A. Dirty/plugged sample filter or sample lines.
  - B. Dirty reaction cell.
  - C. Check leak.
1. Flow rate too low.
  2. Wrong materials in contact with sample - use glass or Teflon.
  3. Insufficient time allowed for purging of lines upstream of analyzer.
  4. Insufficient time allowed for SO<sub>2</sub> cal gas source to become stable or cal gas flow is too low.

### 9.2.12 Analog Output Doesn't Agree With Display Concentration

1. V/F board DAC's out of calibration. Do DAC calibration and Factory Calibration.
2. Analog outputs electrically loaded down causing voltage to sag. Could be due to input impedance of chart recorder or data logger being too low or improper grounding.

## 9.3 Electronic Subsystem Troubleshooting and Adjustments

### 9.3.1 Computer, Display, Keyboard

The purpose of this section is to determine if the computer subsystem electronics hardware are working properly. Assessment will make it the board level.

#### 9.3.1.1 Front Panel Display

The front panel display is a 2 line by 40 character display. It has its own microprocessor to decode commands and display characters. It contains a self test feature. To test the display:

1. Turn off the power to the instrument.
2. Fold down the M100A front panel.
3. Disconnect the 24 line flat ribbon cable (J2) that connects the computer parallel port to the keyboard.
4. Turn on the M100A power switch.
5. Observe the front panel display. If the display successfully completes its power on self test, it will display a single underline character "\_" in the left most character of the top line of the display. If this character is present, the display is working properly.
6. Turn off the power of the analyzer, and re-attach the 24 line cable to J2, and proceed to the next test.

#### 9.3.1.2 Single Board Computer

The SBC40 is a full function computer designed for instrument control applications. It consists of a 16 bit 8088 microprocessor, 2 serial and one parallel ports, standard bus interface, and 4 sockets for memory. The memory sockets consist of: 256k ROM containing the multitasking operating system and application code, 32k E<sup>2</sup>PROM containing the setup variables, 256k RAM containing data collected by the instrument, and a time-of-day clock to provide event timing services. The overall function of this board is quite complex. Complete testing of this board's functions is not possible in the field. If component level troubleshooting of this board is necessary, contact the factory for schematics.

Like the display, the overall functioning of the CPU can be confirmed by a simple test.

1. Locate the CPU board on the mother board by referring to Figure 2-5.
2. Power the instrument on.
3. Locate the red LED at the top left edge of the board.
4. It should be flashing at a frequency of about once per second.
5. This flashing indicates the board is powered up and is executing instructions.

RS-232 diagnostic procedures are described in Section 9.3.2.2. It is possible for the UART driver chip to malfunction in either or both of the input or output ports.

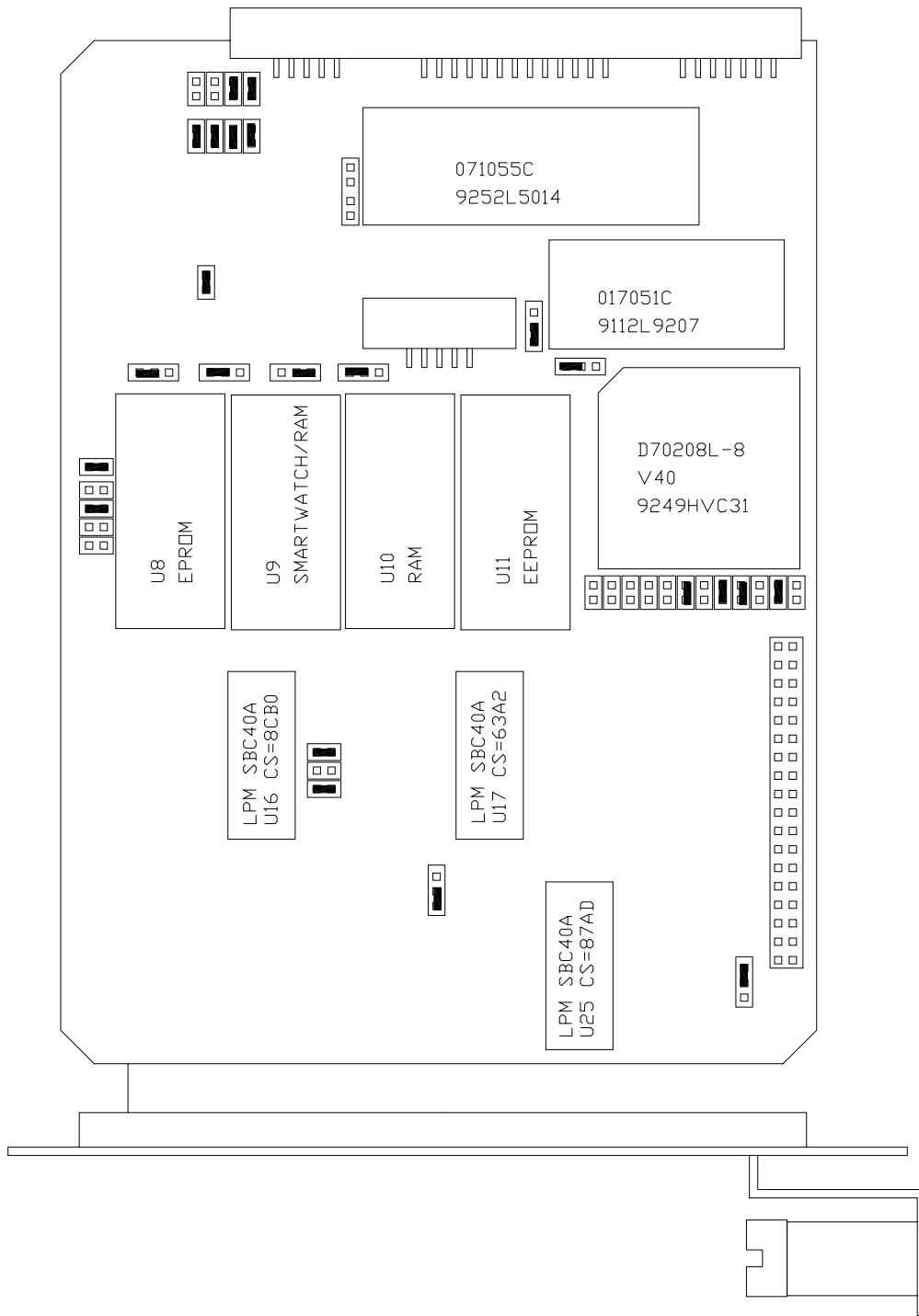

Figure 9-1: CPU Board Jumper Settings

### 9.3.1.3 Front Panel Keyboard

The keyboard consists of 8 keys and 3 LED's. Key strokes are sent to the SBC40 computer's parallel port. The computer software detects the key strokes via interrupts. The bottom line of the display consists of 40 characters which is divided into 8 - 5 character fields. Each field defines the function of the key immediately below it. The definition of the keys is variable and depends on the menu level of the software.

To check the operation of the keyboard, each key should perform an operation indicated by its current definition shown on the second line of the display.

**Example 1** - testing key #1 (left most key).

At the top level menu key #1 is defined as the TEST function. Pressing this key should cause the middle field of the top line of the display to show the various test functions.

**Example 2** - testing key #8 (right most key). At the top level menu key #8 is defined as the SETUP key. Pressing key #8 should cause the SETUP menu to be displayed.

**Example 3** - If the 5 character field above any key is blank, the key is not defined, pressing the key has no effect.

The 3 status LED's indicate several functional states of the instrument such as calibration, fault, and sample modes. The state of the LED's is controlled by 3 lines on the parallel port of the SBC40. Functioning of the LED's can be checked by:

39. Turn off the M100A power.
  1. While watching the LED's, turn on the instrument power.
  2. When the power comes up, the computer momentarily applies power to all 3 LED's for approximately 1 sec. If all the LED's are observed to light, they are working properly.

## 9.3.2 RS-232 Communications

The M100A uses the RS-232 communications protocol to allow the instrument to be connected to a variety of computer based equipment. RS-232 has been used for many years and is well documented. Generally, every manufacturer observes the signal and timing requirements of the protocol very carefully. Problems arise when trying to specify connectors, and wiring diagrams that attach the analyzer to various devices.

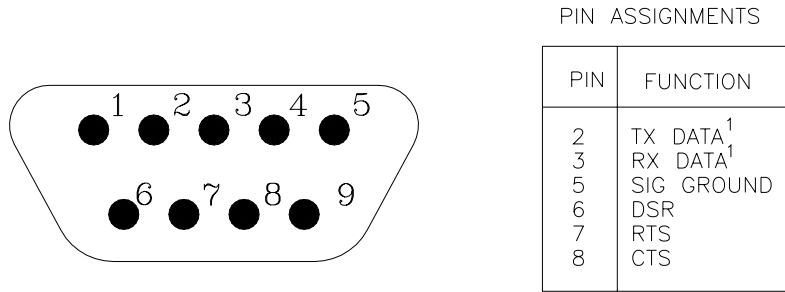

RS-232 CONFIGURATION PARAMETERS

2400 BAUD DEFAULT \*  
 8 DATA BITS  
 1 STOP BIT  
 NO PARITY

\* SETTABLE 300,1200,2400  
 4800,9600,19200 BAUD

<sup>1</sup> JUMPER SETTABLE ON REAR PANEL CONNECTOR BOARD

**Figure 9-2: RS-232 Pin Assignments**

**9.3.2.1 RS-232 Connection Examples**

**Example 1**

Connecting the M100A (using supplied cable) to an IBM-PC AT compatible computer (DB-25 external connector, or DB-25 end of DB-9 to DB-25 Adapter).

In this case, the PC is wired as DTE and the analyzer's jumpers are set as DCE, therefore a null modem is not needed. The wiring is "straight through" i.e. pin 1 to pin 1, pin 2 to pin 2, etc. Therefore all you have to do here is adapt the connector on the analyzer cable (male DB-25) to the DB-25 male on the PC. A female to female DB-25 "gender changer" (cable or adapter) will complete the connection. Make sure none of the adapters have null modems in them.

### **Example 2**

Connecting the Teledyne API analyzer to a serial printer.

In this case, it will be necessary to determine whether the printer is DCE or DTE. Some printers can be configured for either DCE or DTE by jumper or DIP switch settings. Consult the user manual for the printer. If the DB-25 connector pinout shows that data is output on pin 2 (from the printer), then it is DTE and the Teledyne API analyzer's jumpers should be set to DCE mode. If pin 2 of the printer DB-25 is an input to the printer, then set the jumpers of the analyzer to DTE mode. Refer to drawing #01115.

### **Example 3**

Connecting the Teledyne API analyzer to a modem.

The modem is always configured as DCE. Therefore, setting jumpers as the DTE will be required to connect the analyzer to the modem. Refer to drawing #01115.

### **Data Communications Software for a PC.**

You will need to purchase a software package so your computer can transmit and receive on its serial port. There are many such programs, we use PROCOMM at Teledyne API. Once you set up the variables in PROCOMM and your wiring connections are correct, you will be able to communicate with the analyzer. Make sure the analyzer is set up for 2400 baud (SETUP-MORE-COMM-BAUD) and that PROCOMM is set up as described in the "RS-232 Pin Assignments" Figure 9-2.

### 9.3.2.2 RS-232 Diagnostic Procedures

There are several features of the M100A to make connecting to RS-232 and diagnosing RS-232 faults easier.

There are two LED's on the rear panel Connector Board which are connected to pin 2 and 3 of the DB-9 connector on the board. If the jumper block is in the DCE position (default) the red LED is connected to pin 3 of the DB-9 connector. When data is transmitted by the M100A the red LED will flicker, indicating data present on this line. When the M100A is running, the LED will normally be ON, indicating logic low. A one second burst of data can be transmitted over the port by a command in the DIAGNOSTIC menu. Press SETUP-DIAG, scroll to select RS232 and press ENTR to transmit a burst of lower case "w"s.

The green LED is connected to pin 2, if the jumper block is in the default DCE position, this is the pin on which the M100A receives data. It is ON if an outside device is connected. This LED gets its power from the outside device. When data is being transmitted by the outside device to the M100A this LED will flicker.

When you are attempting to configure the RS-232 port, if either of the LED's go out when the cable is connected, that generally means that there is a grounding problem. Check the relative ground levels of pin 5 on the DB-9.

### 9.3.3 Voltage/Frequency (V/F) Board

The V/F Board consists of 16 analog input channels, each software addressable, 8 digital inputs, and 24 digital outputs, each line independently addressable, and 4 independent analog output channels. The analog input channels are connected to V/F converter capable of 80,000 counts, which is approximately 16 bit resolution. The integration period is software selectable from 40m sec to 2.4 sec. Commands from the SBC40 computer and digitized values from the V/F section of the board are sent via the STD bus interface. The schematic for the board is in the Appendix 00514.

The overall operation of this board is quite complex. To fully check it out in all of its operational modes is not recommended in the field. Therefore, a few of simple tests are described here that test one analog input channel, the 4 analog output channels, one digital input, and one digital output.

#### 40. V/F board analog input test.

Each analog channel is routed through a programmable multiplexed 16 channel. Chances are that if one channel works, they all work.

- A. Turn on instrument.
- B. Press TEST key on front panel keyboard until DCPS test is displayed.
- C. The value displayed should read  $2500 \pm 100$  mV  
If the M100A passes this test, it has successfully digitized a 2500 mV composite voltage output from the Power Supply Module. The signal should also be quiet  $\pm 25$  mV.

41. Analog output channel test.

In the DIAGNOSTIC menu on the front panel, there is a test that outputs a step voltage to the 4 analog outputs. This test is useful for calibrating chart recorders and dataloggers attached to the M100A. The test can also be useful in diagnosing faults in the V/F board.

- A. Turn on the instrument.
- B. Enter the SETUP-MORE-DIAG menu.
- C. Scroll to select the ANALOG OUTPUT test. This causes the M100A to output a 5 step voltage pattern to the 4 analog outputs on the rear panel. The status of the test is shown on the front panel display. The scrolling can be stopped at any voltage by pressing the key below the changing percentage display. The values are 0-20-40-60-80-100% of whatever voltage range has been selected. For example the voltages would be 0, 1, 2, 3, 4, 5V if the 5V range had been selected.
- D. Use a DVM on each of the analog output channels to confirm the correct voltages. If the voltages step, but are the wrong values, the V/F board may be out of calibration. See Section 9.3.3.1 for information on how to calibrate the V/F board.

42. Digital input channel test.

The digital I/O section of the V/F board has 8 input bits and 24 output bits. Two of the 8 input bits are assigned as calibration controls. See Section 7.7 for information on calibration using external contact closures.

To test the digital inputs:

- A. Turn the M100A power on.
- B. Connect a jumper wire across REMOTE IN terminals 1 and 2 of the rear panel connector as shown in Figure 2-2.
- C. Shortly after closure is made the instrument should switch into zero mode as indicated on the front panel display.
- D. Remove the jumper. Shortly after the jumper is removed the instrument should exit the zero calibrate mode and enter the HOLDOFF mode. To exit the HOLDOFF mode press EXIT, which will return the instrument to the SAMPLE mode.

1. Digital output channel test.

There are 24 output bits on the V/F board. The 24 bits are made up of three 8 bit ports. It is possible for a single 8 bit port or even a single bit within a port to fail.

A quick observational test of the digital outputs is to observe the LED's in the Power Supply Module (Refer to Figure 9-4 for the location of the LED's in the PSM). A more detailed test is in the DIAGNOSTIC menu. See Diagnostic tests in Section 9.1.3.

### 9.3.3.1 ADC/DAC Calibration Procedure

Due to the stability of modern electronics this procedure should not have to be performed more than once a year or whenever a major sub-assembly is exchanged or whenever analog output voltage range is changed. To calibrate the 4-20 mA current option output, proceed second part of the procedure for the calibration of 4-20 mA current output. After this procedure is completed, a Factory Calibration Procedure should be performed per Section 9.1.6.

To calibrate the DAC's on the V/F board, do the following:

1. Press SETUP-MORE-DIAG-ENTR, then scroll down to the D/A CALIBRATION diagnostic mode, then press ENTR to start the calibration procedure.

Press CFG-SET-VOLT-ENTR to define Voltage output of the corresponding Analog Output Channel. If necessary a recorder offset can be introduced into the analog output voltages. It is intended for recorders that cannot show slightly negative readings. It can also be used to bias the input to a datalogger to offset small external ground loop voltages that are sometimes present in monitoring systems. The recorder offset will bias both the recorder and DAS analog outputs. Enter offset value in mV as needed and press ENTR-EXIT.

2. Press ADC to start the calibration. The M100A display will read "ADJUST ZERO A/D= XX.X mV", where XX.X mV is the target voltage which should be coming out the DAC # 0. Put the probe of a voltmeter (recommend to use 4 1/2 digits meter) on the recorder output terminals 1 and 2 on the M100A rear panel. The value displayed on the front panel and the voltmeter reading should be the same ( $\pm 3$  mV). If they are not, adjust the zero pot (R27) on the V/F board until the two values are the same ( $\pm 1$  mV). Note that the voltmeter reading does not change while adjusting the zero pot (R27). When the voltmeter shows the same value ( $\pm 1$  mV) as the value displayed on the front panel, press ENTR.

DAC #0 is terminals 1 and 2 of the recorder output.

3. The M100A display will now show a new voltage in the same format as above. This voltage will be about 90% of the full scale DAC output range. Now the value displayed on the front panel and the voltmeter reading should be same ( $\pm 3$  mV). If they are not, adjust the gain pot (R31) on the V/F board until the two values are the same ( $\pm 3$  mV). Press ENTR. The DAC #0 is now calibrated and will be used as a voltage reference for calibrating the ADC.
43. Next, the analyzer goes through a procedure which calibrates the other 3 DAC's. When completed press EXIT to return to upper level menus.

Next setup is recommended to verify the quality of the ADC/DAC calibration.

4. Pressing SETUP-MORE-DIAG-ENTR-NEXT, and select ANALOG OUTPUT. Verify the quality of ADC/DAC calibration by measuring the test channel output voltage. The signal consists of a scrolling 0%, 20%, 40%, 60%, 80%, 100% of the analog output value. The scrolling may be stopped by pressing the key underneath the % display to hold that value and will display within the square bracket ( [%] ). Press key once again to continue scrolling or press EXIT to terminate. The exact voltage values depend on the DIP switch settings on the analog output buffer amplifiers.

To calibrate the 4-20 mA current output option, do the following:

**Verify  $\pm 5$  volt output DIP switch setting (refer Figure 9-3) for 4-20 mA option before proceeding with the following procedure, since the input voltage of the isolated 4-20 mA converter hardware is configured for 0 - 5 volt range (0 - 10 volt for non-isolated). The 4 - 20 mA calibration procedure should be performed after verifying the voltage calibration as above.**

1. Connect the 300 - 1000 ohm resistor to one of the 4-20 mA recorder output terminal 1 or 2 (refer Figure 2-2). Connect in series the DC current meter between the resistor and other terminal of the recorder output with proper polarity.
2. Press SETUP-MORE-DIAG-ENTR and scroll down to the D/A CALIBRATION diagnostic mode, press ENTR to start the procedure. Press CFG and scroll by pressing NEXT to select desired current output channel, press SET-CURR-ENTR to define current output channel.
3. Press CAL to start the calibration. The M100A display will read "x)CONC\_OUT\_X,CURR,ZERO", where X the output channel number. Press the up/down buttons on the front panel until the current meter displays 4.0 mA ( $\pm 0.1$ mA). When the current meter shows a stable  $4.0 \pm 0.1$  mA, press ENTR.
4. The M100A display will now show "x)CONC\_OUT\_X,CURR,GAIN". As before, press the up/down buttons on the M100A front panel until the current meter reads  $20.0 \pm 0.1$  mA.
5. Repeat step 1 through 4 for additional current channel output calibration. Each current channel must be calibrated separately. When completed press EXIT to return to upper level menus.
6. Verify that the analog output is correct by performing SETUP-MORE-DIAG-ANALOG OUTPUT (see Section 9.1.3.4). The current meter should read 4, 7.2, 10.4, 13.6, 16.8, and 20 mA accordingly.

### 9.3.3.2 Changing Output Voltage Ranges

Several different output voltage ranges can be selected by DIP switch setting on the V/F board. See Figure 9-3 for the DIP switch settings. **If you change the analog output voltage range, then you must reset the power of the instrument and do a ADC/DAC calibration per Section 9.3.3.1.**

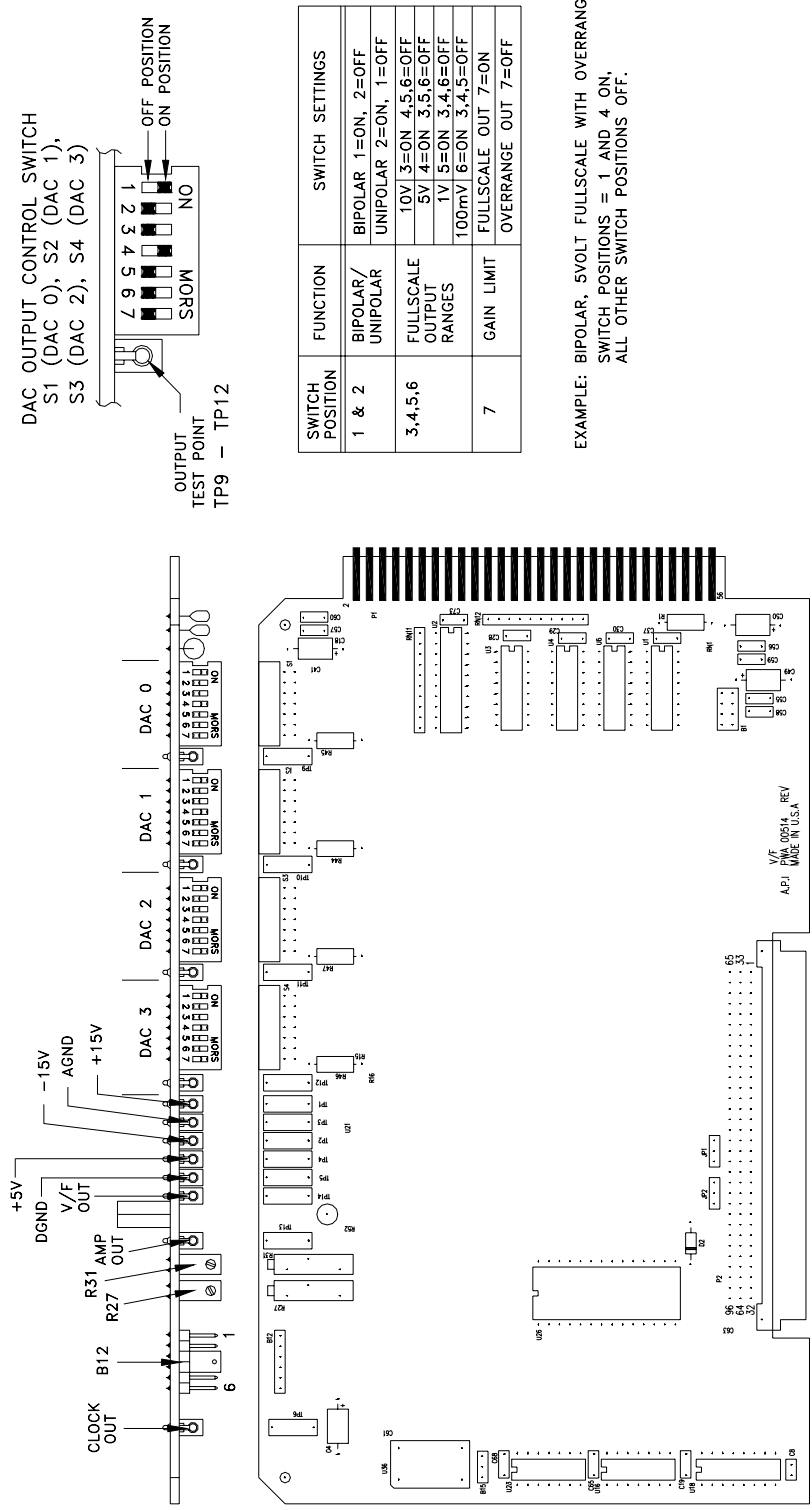

Figure 9-3: V/F Board Dip Switch Settings

### 9.3.4 Status/Temp Board

The Status/Temp Board is a multifunction board that:

1. Converts the resistance readings of the thermistors to voltages
2. Provides status output circuitry
3. Provides circuitry for contact closure inputs
4. Provides circuitry for display brown-out/reset at low line voltage
5. Provides sockets for voltage-to-current modules

#### 9.3.4.1 Temperature Amplifier Section

The Status/Temp board (01086) is a multifunction board consisting of 4 thermistor amplifiers that monitor:

1. IZS temperature
2. Reaction Cell temperature
3. Box temperature
4. Spare

The voltages of the thermistor and thermocouple amplifier outputs are brought out to test points on the edge of the board. Refer to the schematic 01086 for details. The voltages can also be read using the DIAGNOSTIC - SIGNAL I/O feature (see Table 9-4 for details).

#### Thermistor Temperature Amplifier Adjustments

The Status/Temp board has 3 thermistor temperature amplifiers:

1. Reaction Cell Temperature
2. IZS permeation tube heater
3. Box temperature readout

These 3 outputs are controlled by a common pot (R34) on the upper edge of the card.

If the temperature readouts are in error:

1. Adjust R34 of the Status/Temp board to read 2.577 VDC between test point 6 and test point
2. This will cause all of the readouts to accurately measure their respective temperatures.

#### **9.3.4.2 Display Brownout**

During low AC line conditions the display can lock up due to insufficient voltage. When low line conditions are approaching, this circuit senses the condition by monitoring the un-regulated +5VDC in the Power Supply Module. If brownout conditions are met, the DISP\_BROWNOUT line is asserted and the CPU sends a hardware RESET command to the display and sends a BRNOUT RESET pulse back to U4. Brownout conditions will be noticed by the display flashing every 8 seconds.

#### **9.3.4.3 Status Output Lines, External Contact Closures**

The Status lines consist of 2 active input lines, and 12 active output lines. Additional circuits are present on the board but currently unused. Individual lines are set or cleared under CPU control depending on the assigned alarm condition. The CPU also monitors the 2 input lines for remote calibration commands. The status inputs and outputs are terminated at the rear panel, see schematic diagram 01114.

The output lines are opto-coupled NPN transistors which can pass 50 ma max of direct current with a voltage of 30 VDC max (see Schematic 01087).

The input lines are optically coupled with inputs pulled up to +5VDC. External contacts can be contact closures or open channel transistor contacts. DO NOT apply any voltage, since +5VDC is supplied internally (refer to Figure 2-2 and Schematic 01087 for details).

Individual status lines can be set or cleared using the DIAGNOSTIC mode SIGNAL I/O. This can be useful for simulating fault conditions in the analyzer to see if external circuitry is working correctly. See Table 6-3 for pin assignments.

#### **9.3.4.4 Isolated 4-20 mA Current Output**

4-20 mA current loop option replaces the voltage output of the instrument with an isolated 4-20 mA current output. The current outputs come out on the same terminals that were used for voltage outputs (see Figure 2-2). It is programmable for 4-20mA or 0-20mA and has a 1500 V common mode voltage isolation and 240 V RMS normal mode voltage protection.  $V_{loop} = 28V$  max which is sufficient to drive up to a 1000 ohm load. Verify that the jumpers on the motherboard are set properly for the current output mode (refer schematic 01471 and 01248). See Section 9.3.3.1 for the 4 - 20 mA current output calibration procedure.

There are two methods to measure the output of 4-20mA option.

1. Voltage method - preferred method.

Digital type Multi-meters (DMM) are ideally suited for this type of measurement because of their high input impedance - usually 10M ohm or greater. The total load resistance should be between a 200ohm (min) to 1000 (max), precision load resistor of .1% tolerance or better is recommended.

44. Current method.

Although current is constant in a series circuit, accuracy in this type of measurement is usually less precise than with the voltage method due to the type of circuitry used in digital multi-meters. Connect a load resistance (between 200 - 1000ohm) in series with the DMM.

### 9.3.5 Power Supply Module

The Power Supply Module consists of several subassemblies described in Table 9-7 below.

**Table 9-7: Power Supply Module Subassemblies**

Module	Description
Linear Power Supply Board	The linear power supply board takes multiple voltage inputs from the power transformer and produces +5, +15, -15, +12 VDC outputs. The outputs are routed to two external connectors, P2 and P3. See Figure 9-4. The + 5 is used for operating the CPU. The ± 15 is used in several locations for running op-amps and IC's. The + 12 is used for operating fans and valves.
Switching Power Supply	The switching power supply supplies + 15 VDC at 4 A to the PMT cooler control on the Sensor Module. The output is made available through J10 on the Switch Board. There is a load resistor on the Switch Board to keep the output stable when little current is required from the supply.
Switch Board	The Switch Board has many different functions. It takes logic signals from the V/F board and uses them to switch 4-115 VAC and 4-12VDC loads. The board also contains the instrument central grounding tie point. It routes unswitched AC and DC power as needed. Connector J2 programs the power transformers to take 115, 220, or 240 VAC inputs
Power Transformers	There are potentially 2 input power transformers in the instrument. The multitap transformer T1 is in every M100A and supplies input power for the Linear Power Supply board described above. A second transformer T2 is added if 220 or 240 VAC input is required. Input power selection is done via a programming connector P2 which provides the proper connections for either foreign or domestic power.
Circuit Breaker/Power switch	The front panel contains a combination circuit breaker - input power switch. It is connected to the PSM through J6 on the Switch Board. If an overload is detected the switch goes to the OFF position. Switching the power back on resets the breaker also.

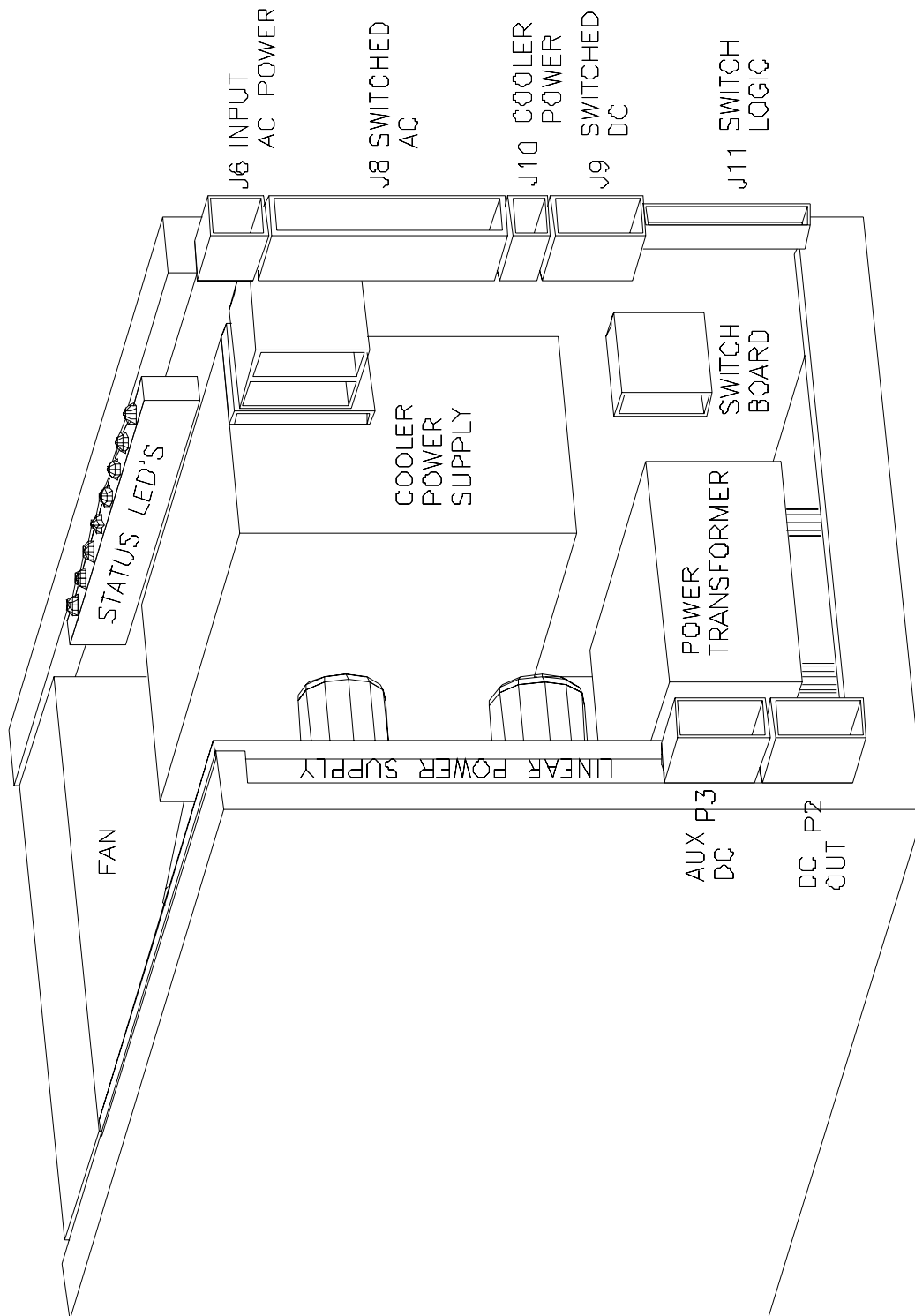
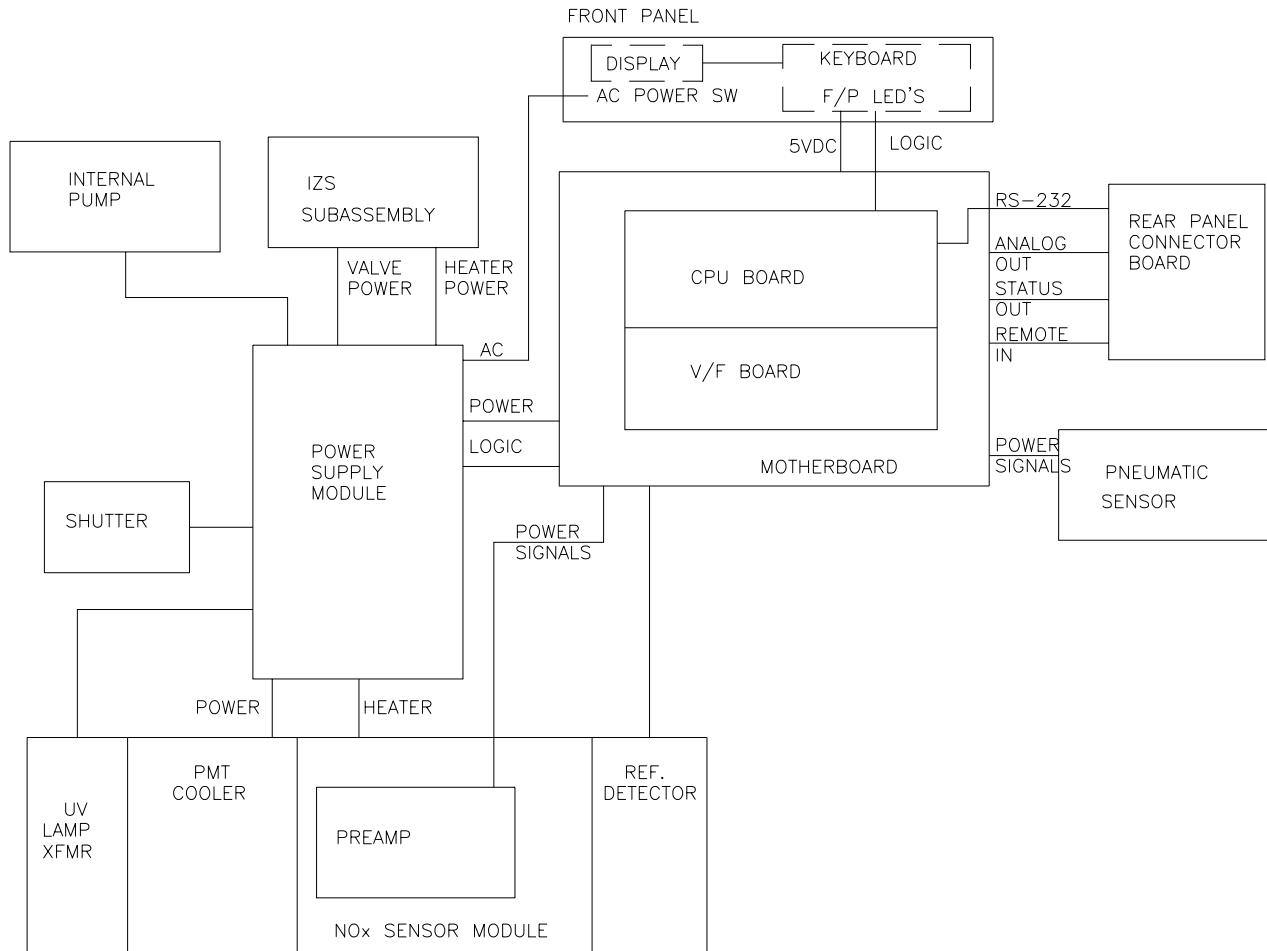

Figure 9-4: Power Supply Module Layout



**Figure 9-5: Electrical Block Diagram**

### 9.3.5.1 PSM Diagnostic Procedures

The Linear Power Supply board can be tested by checking the DCPS - TEST function on the front panel. It should read 2500 mV  $\pm$  200 mV. If the value is outside this range, individual output voltages can be tested on connector P3, see Schematic in the Appendix for pinouts.

The Switching Power Supply output can be tested by observing the temperature of the PMT cold block using the PMT TEMP - TEST function. The temperature should be constant  $\pm$  1°C. The output voltage can be observed on J10 of the Switch Board. It should be 15VDC  $\pm$  .5.

The Switch Board can be tested by observing the diagnostic LEDS along the top edge of the board. The following Table 9-8 describes the typical operation of each LED.

**Table 9-8: Power Supply Module LED Operation**

No.	Function	Description
1	Shutter	Should energize once every 30 minutes for about 15 sec. On = shutter closed mode, Off = shutter open mode. The shutter can be energized manually under SIGNAL I/O of Diagnostic mode. See Section 9.1.3 and Table 9-4.
2	Zero/Span Valve	Should switch ON when CALS button pressed. Span gas input to analyzer.
3	Sample/Cal Valve	Should switch ON when CALS or CALZ buttons are pressed. ON when in calibrate mode.
4	Spare	
5	Spare	
6	IZS Heater	Should cycle ON-OFF every 20 sec to 2 min. On continuously until up to temp.
7	Spare	
8	Reaction Cell Heater	Should cycle ON-OFF every 20 sec to 2 min. On continuously until up to temp.

### 9.3.6 Flow/Pressure Sensor

The flow/pressure sensor board consists of 1 pressure sensor and a flow sensor. See Figure 9-6 for a diagram of this board. From these two sensors pressure and flow rate values are computed and displayed on the front panel TEST functions. They are:

1. Sample gas pressure - measured directly S1, adjust R1.
2. Sample Flow - measured directly S3, adjust R3.

The above pressure and flow are filtered to produce the front panel readings. Several minutes may be required for a steady reading if observing the TEST functions.

To adjust the sample flow, proceed as followings;

1. Remove the 1/8" fitting from the reaction cell.
2. Scroll to select SFLOW of the TEST functions.
3. Using independent flow meter verify the flow rate into the reaction cell.
4. Adjust R3 of the flow/pressure board to match the front panel display to the flow rate of independent flow meter.
5. If not able to adjust then replace the flow sensor.

To adjust the sample pressure, proceed as followings;

1. Remove the 1/4" fitting from the reaction cell.
2. Scroll to select PRES of the TEST functions.
3. Adjust R1 of the flow/pressure board to read current ambient barometric pressure (typical value at sea level is 29.9 Hg-In).
4. If not able to adjust then replace the pressure sensor.

FLOW AND PRESSURE  
READOUT ADJUSTMENT  
INSTRUCTIONS:

1. SELECT THE DESIRED TEST FUNCTION ON THE FRONT PANEL.
2. ADJUST THE APPROPRIATE POT PER THE TABLE BELOW UNTIL THE CORRECT READING IS OBSERVED ON THE FRONT PANEL.

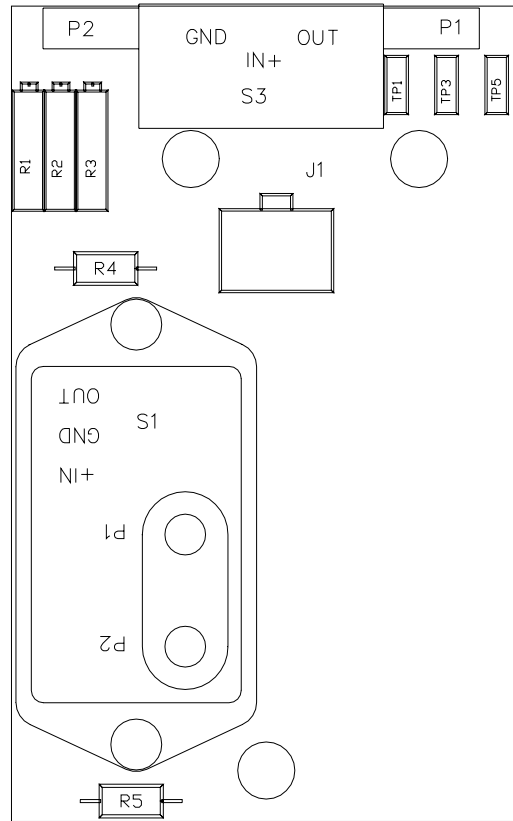

SENSOR, TESTPOINT, ADJUSTMENT	M100A FUNCTION	VOLTAGE NOM.
S3, TP3, R3	SAMPLE FLOW	10V
S1, TP1, R1	PRESSURE	8V

**Figure 9-6: Flow/Pressure Sensor**

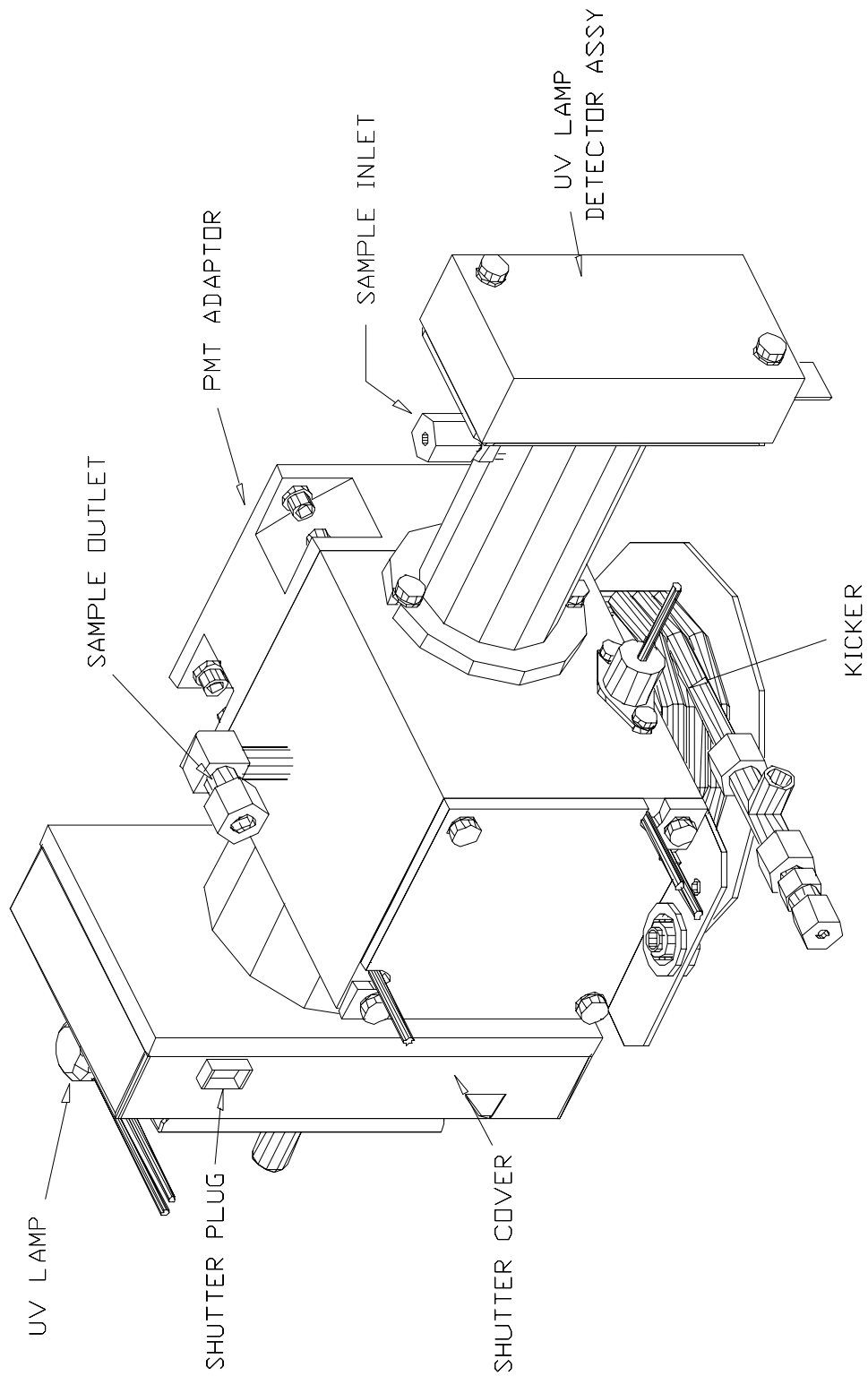

Figure 9-7: SO<sub>2</sub> Sensor Module

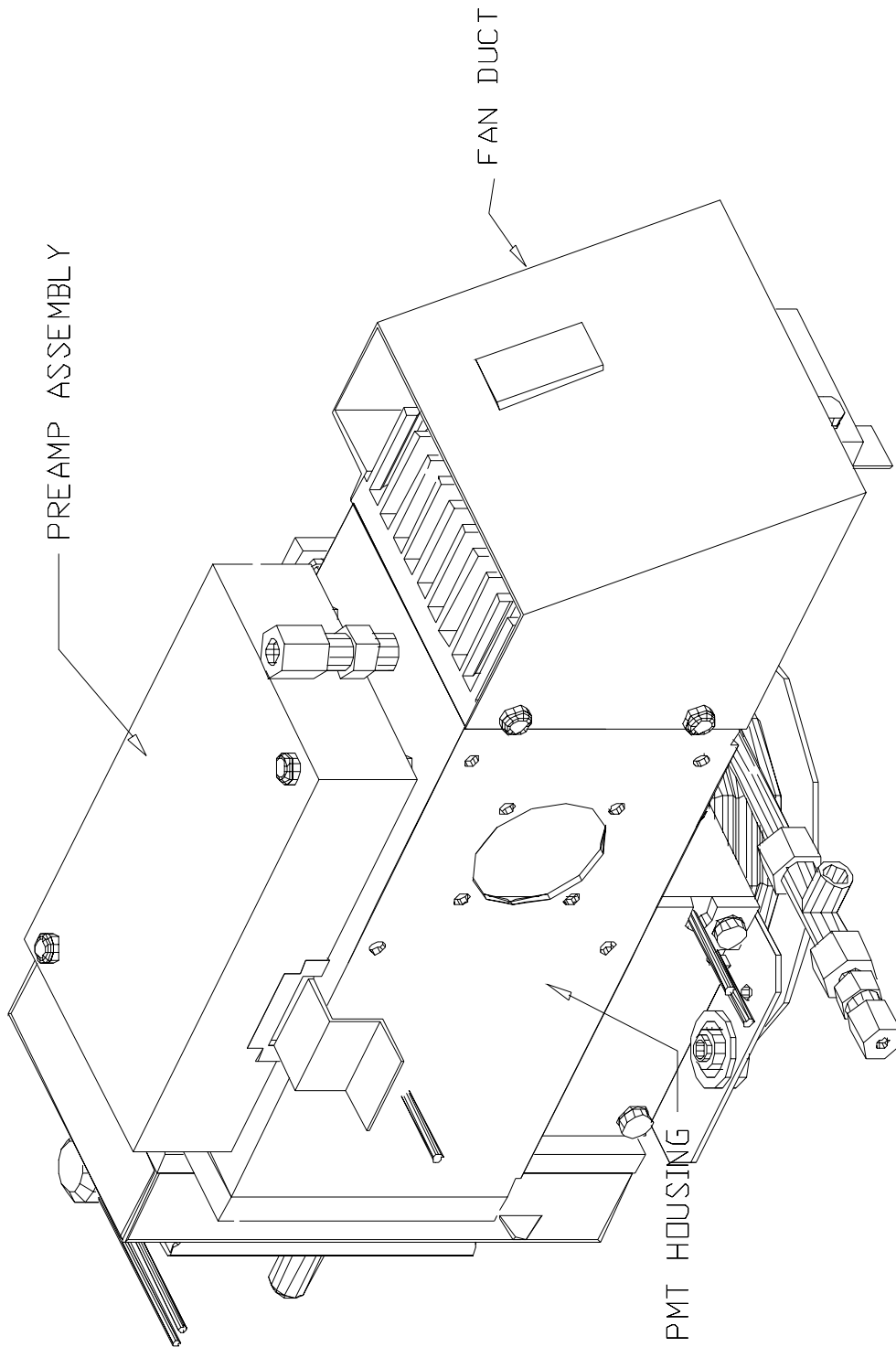

Figure 9-8: SO<sub>2</sub> Sensor Module

### 9.3.7 Reaction Cell Temp

The reaction cell temperature is controlled by the CPU. It operates by reading a thermistor amplifier on the 01086 Status/Temp board. First LED from the front indicates the control power on-off status which can be seen from the cover of the PSM through the slot.

### 9.3.8 Preamp Board

The Preamp Board is a multifunction board providing circuitry to support the following functions.

1. Preamp, buffer amplifier, physical range control hardware for the PMT detector.
  2. Precision voltage reference and voltage generation, and control for the PMT - HVPS inside the sensor module.
  3. Constant current generator and adjustment for the Optic Test LED.
  4. Voltage generation and adjustment for Electric Test.
45. Thermistor amplifier and temperature control circuit for the PMT cooler.

The setup and adjustment of items 1-4 above is covered in the Factory Calibration procedure in Section 9.1.6. Item 5 (see Section 9.3.9) is not adjustable.

### 9.3.9 PMT Cooler

The PMT cooler uses a Thermal Electric Cooler (TEC) supplied with DC current from the switching power supply in the Power Supply Module. An overall view is shown in Figure 9-9. The temperature is controlled by a temperature controller circuit located on the Preamp board. Voltages applied to the cooler element vary from 0.1 to 12VDC. The input voltage from the supply is 15VDC and LED indicates the presence of the voltage. Typical control voltage to the FET is about 4.0 VDC when PMT temperature is at the 7°C setpoint. At normal room temperatures the 7°C set point should be maintained within 0.1°C. These voltages can be measured from the PCB mounted in the fan shroud. TP1 and TP4 (white) should measure 15VDC and the control voltage to the gate of the FET can be measured between pin 2 of the white plug and TP4. Also under normal room temperature and at the 7°C PMT set point the voltage between TP2 and TP3 will typically measure between 0.15V- 0.2V which translates to about 1.5-2 Amp DC current flowing through the Thermal Electric Cooler (TEC). Following procedures show how to replace the TEC assembly.

1. Remove three screws that hold the sensor assembly (refer to Figure 2-1 they are located adjacent to the shipping screws).
2. Remove four screws that hold the fan duct and unplug cable plugs from the fan duct assembly.
3. Remove four screws holding the heatsink assembly from the PMT housing assembly and separate these two assembly carefully by pulling heatsink assembly slowly out of the PMT housing until HVPS module is completely out of the PMT housing (refer to Figure 9-8).
4. Remove two screws from the HVPS module to separate HVPS module from the cooler block.

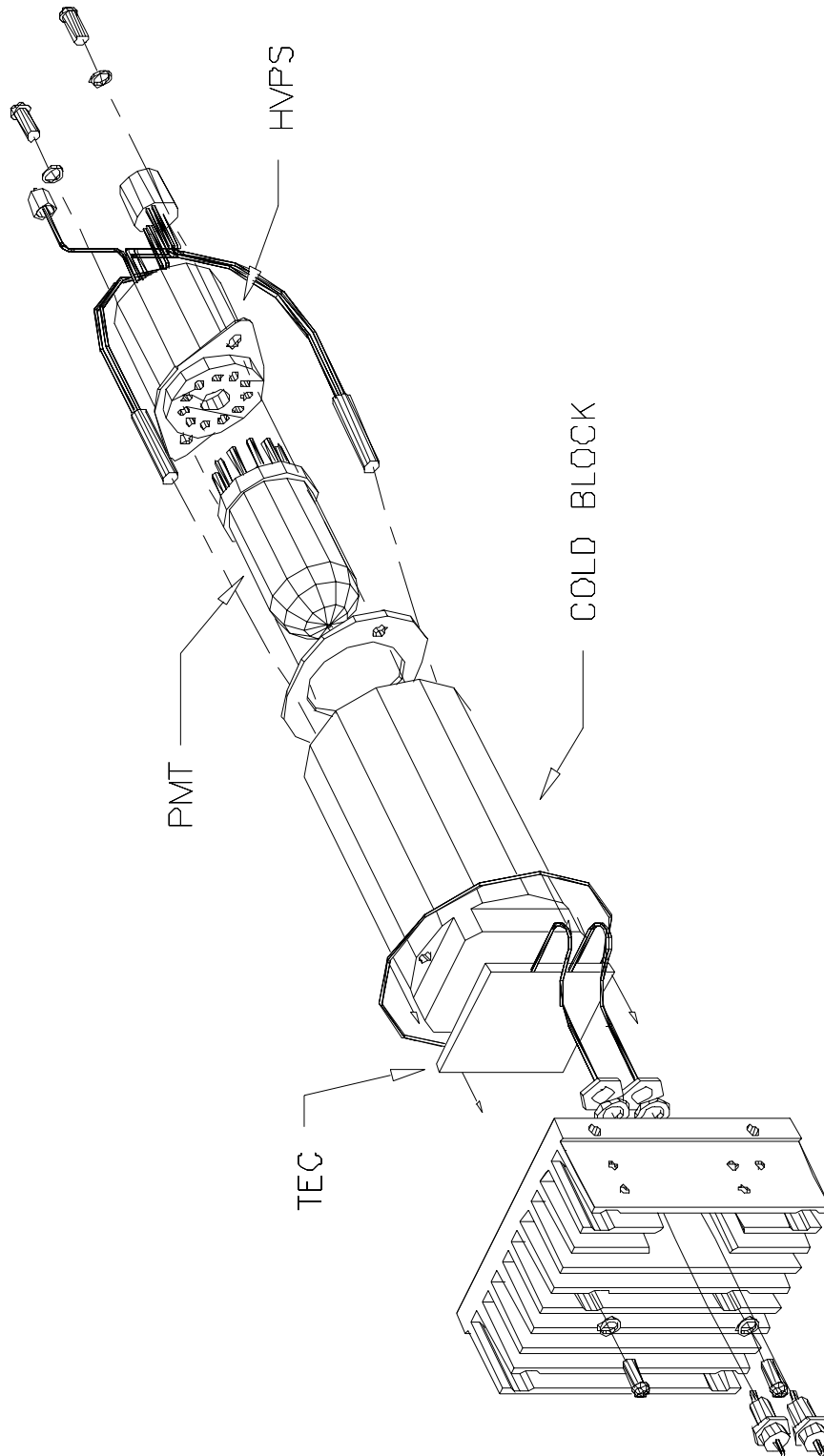

Figure 9-9: PMT Cooler Subsystem

5. Pull out PMT, LED, and thermistor carefully from the cooler block. Be careful not to contaminate the window of the PMT with thermal compound of thermistor. PMT is fragile, so handle carefully.
6. Replace two desiccant bags inside of the PMT housing with new bags.
7. Replace cooler assembly (P/N 01461) and assemble by reversing above steps.

### **9.3.10 HVPS (High Voltage Power Supply)**

The HVPS is located in the interior of the Sensor Module, and is plugged into the PMT tube. It requires 2 voltage inputs. The first is +15VDC which powers the supply. The second is the programming voltage which is generated on the Preamp Board. The test procedure below allows to test HVPS. Adjustment of the HVPS is covered in the Factory Calibration Procedure in Section 9.1.6.

To troubleshoot the HVPS:

1. While sampling stable SO<sub>2</sub> gas, record PMT reading and HVPS reading of the TEST function.
2. Change HVPS voltage about 50V lower than the current setting by adjusting S2 and S1 on the preamp board. If PMT reading on the display drops about 40±10% from the previous reading, then HVPS is working properly.
3. If PMT reading does not drop, then do ELECTRIC test per 9.1.3.2.
4. If ELECTRIC test is working properly, then do OPTIC test per 9.1.3.3.

If all above are checked properly, then problem is either PMT or HVPS. Check HVPS as followings

46. Turn off the instrument.
  5. Remove the cover and disconnect the 2 connectors at the front of the SO<sub>2</sub> PMT housing.
  6. Remove the end plate from the PMT housing.
  7. Remove the HVPS/PMT assembly from the cold block inside the sensor. Un-plug the PMT tube.
  8. Re-connect the 7 pin connector to the Sensor end cap, and power-up the instrument.

9. Use Figure 9-10 to check the voltages at each pin of the supply, and the overall voltage.
10. Turn off the instrument power, and re-connect the PMT tube, then re-assemble the sensor.

If any faults are found in the test, you must obtain a new HVPS as there are no user serviceable parts inside the supply.

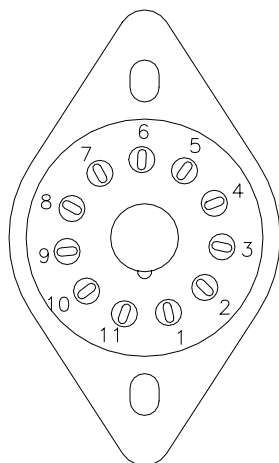

To test the HVPS, follow the procedure outlined in Section 9.3.10 of the manual. Then:

1. With the instrument disassembled as described and the power turned on, check the HVPS – TEST function on the front panel.
2. Divide the observed HVPS voltage by 10 and test the following pairs of points. The voltage should be 1/10 of the HVPS voltage for each pair.

For Example: If the voltage was 700VDC, the voltage at each stage would be 70VDC.

HVPS  
PINS      VOLTAGE

11-1	70
1-2	70
2-3	70
3-4	70
4-5	70
5-6	70
6-7	70
7-8	70
8-9	70
9-10	70

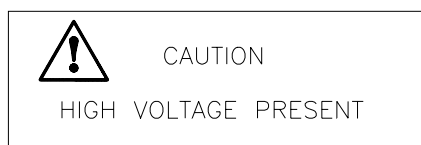

3. Each stage should have the same voltage. If so the HVPS is working.

**Figure 9-10: High Voltage Power Supply**

## 9.4 Optical Sensor Module Troubleshooting

### 9.4.1 PMT

The PMT detects the light emitted by the secondary emission of the SO<sub>2</sub> molecules. It has very high gain and low noise to detect the weak light source optimally. It is not possible to test the detector outside of the instrument in the field. The best way to determine if the PMT is working is by using Optic test. OT operation is described in Section 9.1.3.3.

The basic method to diagnose a PMT fault is to eliminate the other components using ET, OT and specific tests for other sub-assemblies.

### 9.4.2 UV Lamp Adjust or Replacement

As the UV lamp output changes, the SO<sub>2</sub> concentration will change. There are four main types of energy changes or fluctuations associated with the UV lamp:

1. Line voltage changes - UV lamp energy is directly proportional to the line voltage.
47. Lamp short term drift - Over a period of hours, the UV emitted from the lamp may increase or decrease slightly.
  2. Lamp aging - Over a period of months, the UV energy will show a downward trend, usually 30% in the first 90 days, and then a slower rate, until the end of useful life of the lamp, 2-3 years nominally.
  3. Lamp positioning - The physical alignment of the lamp in its holder (which is optimized by **PEAKING** the lamp, originally at the factory) may be disturbed.

To adjust or to replace the UV lamp, proceed as followings;

1. Loosen the thumbscrew to allow the lamp to move freely. Replace the lamp if needed.
2. Adjust the POT on the UV reference preamp to the minimum. The preamp assembly is located at the opposite end of the UV lamp assembly. Remove the cover by loosening two screws.
3. Slowly rotate or move the lamp vertically while monitoring the UV LAMP display to read maximum value.
4. Finger tight the thumbscrew.
48. Adjust the POT to approximately 3500 mV.
49. Place the cover of UV reference preamp assembly.
  5. Perform lamp calibration as described in Section 9.1.6.



**NOTE**

**The operations outlined in this chapter are to be performed by qualified maintenance personnel only.**

If the UV LAMP display is lower than 1000mV after peak adjustment, it is recommended to replace the lamp. Most UV lamps that produces UV lamp reading above 1000 mV are still in good condition. UV LAMP reading below 600 mV will cause the instrument to display XXXXX.X.

### 9.4.3 UV Filter Replacement

To replace the UV filter, proceed as followings;

1. Turn off the instrument's power and remove the power cord from the instrument.
2. Unplug J4 connector from the motherboard to allow tool access.
3. Remove 4 screws from the shutter cover (refer to Figure 9-7) and remove the cover .
4. Remove 4 screws from the UV filter retainer.
5. Carefully remove the UV filter.
6. Install the UV filter. Handle carefully and never touch the filter's surface. UV filter's wider ring side should be facing out.
7. Install UV filter retainer and tighten screws.
8. Install the shutter cover and minifit connector. Tighten 4 screws.
9. Plug J4 connector into the motherboard.

### 9.4.4 Shutter System

The shutter is used to check the PMT and correct for the dark current drift. It consists of the solenoid and shutter blade which is controlled by the valve control circuit in the PSM (power supply module). It can be manually energized to verify its functionality.

1. Press DIAG, then press ENTR to select SIGNAL I/O. Then scroll to number five (5) and toggle OFF to ON to energize the solenoid.

50. Without leaving DIAG menu, Scroll until PMT\_SIGNAL is shown. It should display near  $0 \pm 200$  mV. If reading is greater than +200 mV, then verify if + 12VDC is supplied for the terminal located at the shutter cover(see Figure 9-7). If + 12VDC is present, then open the shutter cover and verify if shutter or solenoid is mechanically faulty. Replace as necessary.

## 9.5 Pneumatic System Troubleshooting

The pneumatic system is diagrammed in Figure 8-3 depending on which options the instrument was ordered with.

### 9.5.1 Leak Check

#### CAUTION

**When doing a leak check do not pressurize the M100A to greater than 15psig. Damage to internal components will occur at higher pressures.**

Many performance problems cause is a leak. Refer to Section 8.8 for the leak check procedure.

### 9.5.2 Pump

The internal vacuum pump is capable of 14"Hg Abs pressure at 1 slpm or better to maintain critical flow. Plug inlet of the rear panel and if higher pressures are noted, the pump may need servicing. Pneumatic leak also can cause higher pressure.

### 9.5.3 Kicker

The Kicker assembly consists of the membrane tube and Teflon tube. The pump creates the vacuum between the membrane and the Teflon tube causing a differential pressure. Poly-nuclear Hydrocarbon in the sample is removed while passing through membrane tube by this differential pressure. Leak check as Section 8.8 and flow check as in Section 9.2.2. An internal leak of the Kicker is difficult to find. Leak check only the membrane tube as followings to determine internal leak of the kicker (you need leak checker to perform this procedure).

51. One end of the kicker is connected to the sample particulate filter assembly and the other end is connected to the reaction cell assembly. Both ends are made of the 1/8" black Teflon tubing. Cap one end of the kicker and pressurize the other end of the kicker using leak checker (refer to Figure 9-11). Do not exceed pressure more than 15 psi and do not pull the vacuum through the Kicker.
  1. Close the shut-off valve. If the gauge pressure drops 1 psi within 5 minutes, then kicker has internal leak. **The kicker assembly is only factory serviceable.**

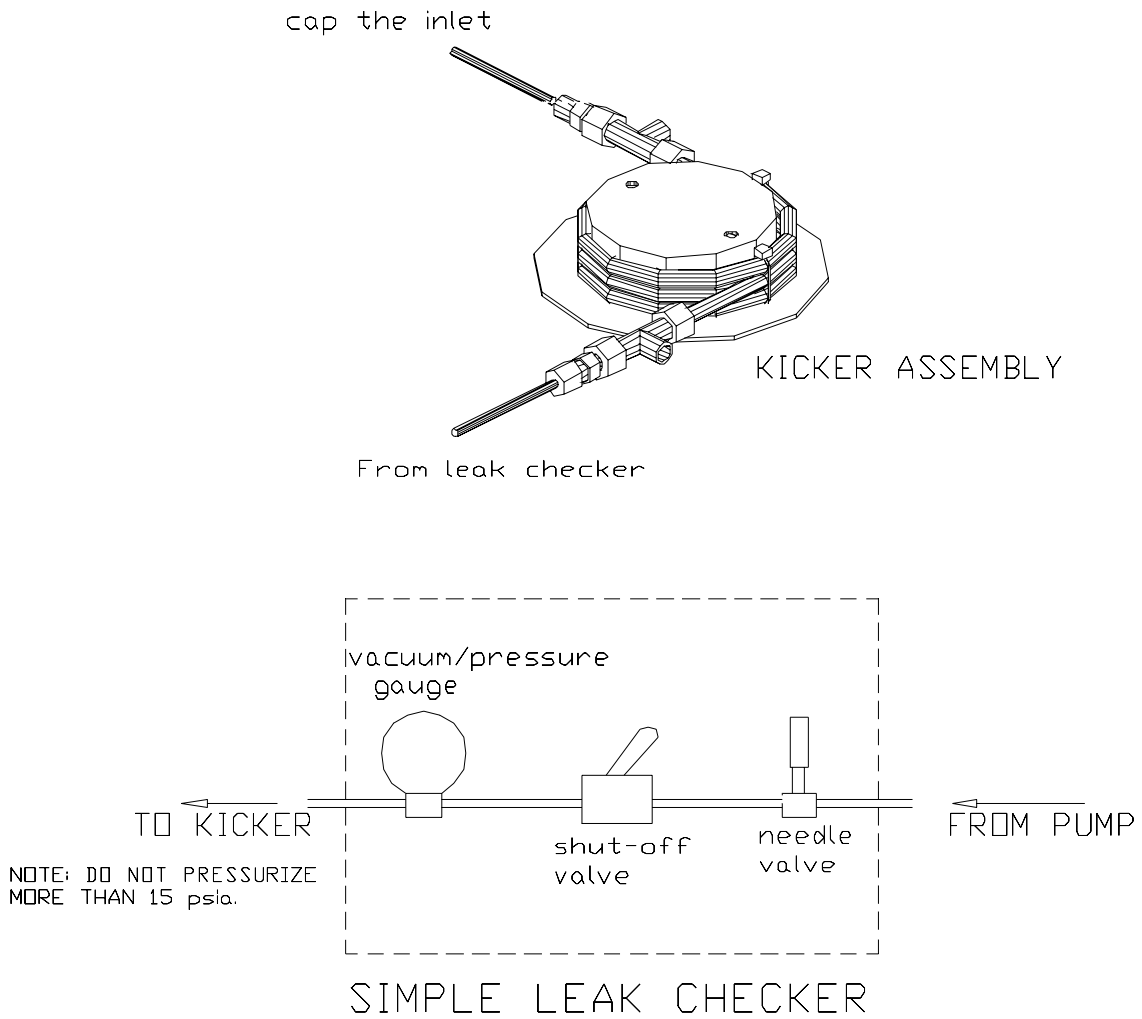

**Figure 9-11: Kicker Leak Check**

## 9.5.4 Z/S Valves & IZS Permeation Tube Oven

The Z/S Valves and IZS are both options in the instrument. Before troubleshooting this sub-assembly, check that the options were ordered, and that they are enabled in the software (if not call factory).

Check for the Z/S valves:

1. Check for the physical presence of the valves. See Figure 2-5 for Z/S Valve location.
52. Check front panel for option presence. The front panel display when the instrument is in SAMPLE mode should display CALS and CALZ buttons on the second line of the display. The presence of the buttons indicates that the option has been enabled in software.

Troubleshooting the Z/S valves.

53. It is possible to manually toggle each of the valves in the DIAGNOSTIC mode. Refer to Section 9.1.3 for information on using the DIAG mode. Also refer to Figure 8-3 for a pneumatic diagram of the system.

Check for the IZS option:

1. Check for the physical presence of the IZS oven. See Figure 2-5 for the Z/S Valve location.
2. Check front panel TEST functions for presence of IZS temperature (if not call factory). If IZS temperature is displayed, the IZS oven temperature control algorithm and temperature display has been enabled in the software.

## 10 TELEDYNE API M100A SPARE PARTS LIST

**Note:** Use of replacement parts other than those supplied by Teledyne API may result in non-compliance with European Standard EN61010-1.

**Table 10-1: Teledyne API M100A Spare Parts List**

PART NO	DESCRIPTION
000940100	Orifice, 3 mil, 60 cc (IZS)
000940800	Orifice, 12 mil, 650 cc, Rx Cell
002620100	UV Lamp Assembly
002690000	Lens, UV (002-039700)
002700000	Lens, PMT (002-039800)
002720000	PMT Optical Filter (002-035300)
002761100	CPU Board (100A PRE-AMX)
002761900	CPU Board (100A AMX)
003290000	Thermistor Assembly (885-071600)
003370000	Heater/Thermistor Assembly (Rx Cell)
003690000	Filter, TFE, 37 mm, Qty. 100 (872-006400)
003690100	Filter, TFE, 37 mm, Qty. 25 (872-006300)
004020300	Sensor Board
004840000	UV Transformer Assembly, 60 Hz (002-038800)
004840100	UV Transformer Assembly, 50 Hz (002-038801)
005140300	V/F Board
005960000	Activated Charcoal, 6 lbs
007040000	Keyboard
007280000	NEW Display
008160000	M100 47 mm Filter Holder
009690000	Filter, TFE, 47 mm, Qty. 100
009690100	Filter, TFE, 47 mm, Qty. 25
010860000	Status/Temperature Board
011390000	Assembly, Power Supply Module - 115V/60Hz

*(table continued)*

**Table 10-1: Teledyne API M100A Spare Parts List (Continued)**

<b>PART NO</b>	<b>DESCRIPTION</b>
011390200	Assembly, Power Supply Module - 220V/50Hz
011390400	Assembly, Power Supply Module - 240V/50Hz
011900000	37 mm Sample Filter Assembly
012360000	Fan, Power Supply Module
013140100	Fan, PMT Cooler
013390000	Kicker Assembly, M100A
013400000	PMT, SO <sub>2</sub>
013420000	Rotary Solenoid Assembly (Shutter Solenoid)
013570000	Thermistor Assembly (Cooler)
014080100	Assembly, High Voltage Power Supply
014400000	Zero Air Scrubber for IZS
014610000	Cooler Assembly
014740000	M100A 37 mm Filter Expendables Kit
014740200	M100A 47 mm Filter Expendables Kit
014750000	M100A Expendables Kit - IZS
014760000	M100A Level 1 Spares Kit
014760100	M100A Spares Kit for 1 Unit
015280000	SO <sub>2</sub> PROM with Software
018620000	IZS Retrofit, M100A w/o valves
018630000	IZS Retrofit, M100A, w/ Valves, IZS
019300000	Keyboard
021070100	PMT Pre-amplifier Board Assembly
021640000	Instruction Manual for M100A
022300000	DC Power Supply Board
024180000	CD, UV Filter 214 NM
024180000	CD, UV Filter 214 NM
024310000	O-Ring, Teflon Retaining Ring 37mm
024710000	Tubing: 6', 1/8" CLR

*(table continued)*

**Table 10-1: Teledyne API M100A Spare Parts List (Continued)**

<b>PART NO</b>	<b>DESCRIPTION</b>
024720000	Tubing: 6', 1/8" BLK
024750000	Tubing: 6', 1/4" TYGON
FL0000001	Sintered Filter (002-024900)
FL0000003	Filter, DFU (036-040180)
FM0000004	Flow Meter, 0-1000 cc
HE0000018	Heater, 50W (IZS)
HW0000020	Spring, Flow Control
HW0000036	TFE Thread Tape (48 FT)
HW0000123	Shockmount, Pump
HW0000150	CLamp, Hose, Nylon, 1/4"
KIT000010	Retrofit, Preamp/TEC Cntl, M100A
KIT000013	Retrofit, M100A AMX
KIT000019	Replacement Cooler Assembly, M100A/M200A
KIT000021	Replacement PWR SW BD, 'A', M100A/200A
KIT000028	Retrofit , 37mm Retaining Ring, Sample Filter
KIT000029	Retrofit , 47mm Retaining Ring, Sample Filter
KIT000030	Scrubber Canister, Short, M100A
KIT000045	Retrofit, Z/S Valves, M100A
OP0000012	UV Detector
OR0000001	O-Ring, Flow Control
OR0000004	O-Ring, Optic/Cell, Cell/Trap
OR0000006	O-Ring, Cell/PMT
OR0000007	O-Ring, PMT, Barrel, Cell
OR0000013	O-Ring, UV Detector
OR0000015	O-Ring, PMT Filter
OR0000016	O-Ring, UV Lens
OR0000025	O-Ring, Zero Air Scrubber
OR0000042	O-Ring, Sensor Assembly

*(table continued)*

**Table 10-1: Teledyne API M100A Spare Parts List (Continued)**

PART NO	DESCRIPTION
OR0000046	O-Ring, Permeation Oven
PS0000002	High Voltage Power Supply
PS0000010	15V Switching Power Supply
PU0000020	Pump, 115V 50/60 Hz
PU0000022	Pump Rebuild Kit, KNF Model #NO5ATI
RL0000008	Solid State Relay, 12 Vdc
RL0000015	Solid State Relay, 115 Vac
SW0000006	Overheat SW, Cell/Oven
SW0000008	Pressure Sensor
VA0000033	3-Way Solenoid Valve, Teflon, 12V

**Table 10-2: Teledyne API M100A Level 1 Spares Kit**

PART NO.	DESCRIPTION	
014760000	M100A LEVEL 1 SPARES KIT	
<b>INCLUDES:</b>		<b>QTY</b>
002620100	UV Lamp Assembly	1
004020300	Sensor Board	1
013400000	PMT, SO <sub>2</sub>	1
014610000	Cooler Assembly	1
HW0000101	Shockmount, Pump	4
OP0000012	UV Detector	1
PS0000002	High Voltage Power Supply	1
PU0000020	Pump, 115V 50/60 Hz	1
PU0000022	Pump Rebuild Kit, KNF Model #NO5ATI	1
RL0000008	Solid State Relay, 12 VDC	1
NOTE01-023	Service Note, How to Rebuild KNF Pump	1
KIT0000093	Replacement KIT, 214 NM Filter	1

**Table 10-3: Teledyne API M100A 37 mm Expendables Kit**

<b>PART NO.</b>	<b>DESCRIPTION</b>	
014740000	M100A 37 MM FILTER EXPENDABLES KIT	
<b>INCLUDES:</b>		<b>QTY</b>
003690100	Filter, TFE, 37 mm, Qty. 25 (872-006300)	1
FL0000001	Sintered Filter (002-024900)	2
HW0000020	Spring, Flow Control	2
OR0000001	O-Ring, Flow Control	4
PU0000022	Pump Rebuild Kit, KNF Model #NO5ATI	1
NOTE01-023	Service Note, How to Rebuild KNF Pump	1

**Table 10-4: Teledyne API M100A 47 mm Expendables Kit**

<b>PART NO.</b>	<b>DESCRIPTION</b>	
014740200	M100A 47 MM FILTER EXPENDABLES KIT	
<b>INCLUDES:</b>		<b>QTY</b>
009690100	Filter, TFE, 47 mm, Qty. 25	1
FL0000001	Sintered Filter (002-024900)	2
HW0000020	Spring, Flow Control	2
OR0000001	O-Ring, Flow Control	4
PU0000022	Pump Rebuild Kit, KNF Model #NO5ATI	1
NOTE01-023	Service Note, How to Rebuild KNF Pump	1

**Table 10-5: Teledyne API M100A Expendables Kit - IZS**

<b>PART NO.</b>	<b>DESCRIPTION</b>	
014750000	M100A EXPENDABLES KIT IZS	
<b>INCLUDES:</b>		<b>QTY</b>
005960000	Activated Charcoal, 6 lbs	1
FL0000001	Sintered Filter (002-024900)	2
FL0000003	Filter, DFU (036-040180)	1
OR0000001	O-Ring, Flow Control	4
OR0000046	O-Ring, Permeation Oven	2
HW0000020	Spring	2
006900000	Retainer Pad, Charcoal	4

**Table 10-6: Teledyne API M100A Spares Kit For 1 Unit**

<b>PART NO.</b>	<b>DESCRIPTION</b>	
014760100	M100A Spares Kit for 1 Unit	
<b>INCLUDES:</b>		<b>QTY</b>
003290000	Thermistor Assembly (885-071600)	1
012360000	Fan, Power Supply Module	1
013140100	Fan, PMT Cooler	1
RL0000008	Solid State Relay, 12 Vdc	1
RL0000015	Solid State Relay, 115 Vac	1
KIT0000093	Replacement KIT, 214 NM Filter	1

## APPENDIX A MAINTENANCE SCHEDULE FOR M100A

DATE INSTRUMENT RECEIVED _____													
	JAN	FEB	MAR	APR	MAY	JUNE	JULY	AUG	SEPT	OCT	NOV	DEC	
PARTICULATE FILTER ELEMENT													REPLACE WEEKLY AS NEEDED.
CHARCOAL ZERO AIR SCRUBBER													REPLACE QUARTERLY.
DFU PARTICULATE FILTER FOR ZERO AIR													REPLACE ANNUALLY.
PNEUMATIC LINES													EXAMINE AND REPLACE AS NECESSARY.
LEAK CHECK AND QUICK CAL													CHECK ANNUALLY. SEE SECTION IN MANUAL. LEAK CHECK AFTER ANY MAINTENANCE THEN FOLLOW QUICK CAL.
PUMP DIAPHRAGMS													EVERY 12 MONTHS.
SAMPLE ORIFICE													REPLACE O-RINGS AND FILTER ANNUALLY
SAMPLE FLOW													CHECK FOR PROPER FLOW 650±10% CC/MIN. ANNUALLY

INTENTIONALLY BLANK

## APPENDIX B Electrical Schematics

Part Number	Name
00402	Sensor Board Assembly
00403	Sensor Board Schematic
00514	V/F Board Assembly
00515	V/F Board Schematic
00704	Keyboard, non CE
00705	Keyboard Schematic, non CE
0108600	Status/Temp Assembly
01087	Status/Temp Schematic
01114	Rear Panel PCB, non CE
01115	Rear Panel PCB Schematic, non CE
01139	Power Supply Wiring Diagram
01248	Motherboard Assembly
01249	Motherboard Schematic
01311	Reference Preamp Assembly
01312	Reference Preamp Schematic
01471	4-20mA Output, Option
01839	TEC Control PCB Assembly
01840	TEC Control PCB Schematic
01916	Connector Board Assembly
01917	Connector Board Schematic
01930	Keyboard Assembly
01931	Keyboard Schematic
02107	Preamp Board Assembly
02108	Preamp Board Schematic
02222	Switch Board Assembly
02223	Switch Board Schematic
02230	DC Power Supply Assembly
02231	DC Power Supply Schematic

INTENTIONALLY BLANK